

Course Overview

This course is an introduction to electromagnetic fields and forces. Electromagnetic forces quite literally dominate our everyday experience. The reason we do not fall through the floor to the centre of the earth as we are reading this is because we are floating on (and held together by) electrostatic force fields. However, we are unaware of this in a visceral way, in large part because electromagnetic forces are so enormously strong, 10^{40} times stronger than gravity.

Because of the strength of electromagnetic forces, any small imbalance in net electric charge gives rise to enormous forces that act to try to erase that imbalance. Thus, in our everyday experience, matter is by and large electrically neutral, and our direct experience with electromagnetic phenomena is disguised by many subtleties associated with that neutrality. This is very unlike our direct experience with gravitational forces, which is straightforward and unambiguous.

The objectives of this course are to tease out the laws of electromagnetism from our everyday experience by specific examples of how electromagnetic phenomena manifest themselves.

After completing this course, one will be able

to describe, in words, the ways in which various concepts in electromagnetism come into play in particular situations;

to represent these electromagnetic phenomena and fields mathematically in those situations;

and to predict outcomes in other similar situations.

The overall goal is to use the scientific method to come to understand the enormous variety of electromagnetic phenomena in terms of a few relatively simple laws.

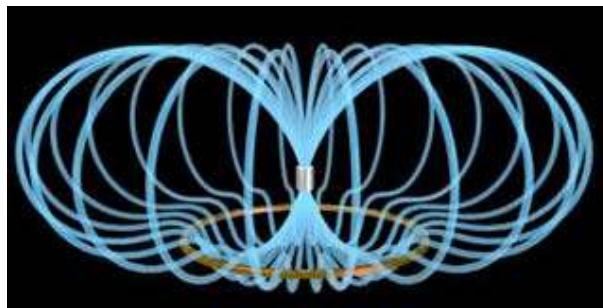

Magnet levitating above a superconducting ring: The image shows a permanent magnet levitating above a conducting non-magnetic ring with zero resistance. The magnet is levitated by eddy currents induced in the ring by the approaching magnet. These currents are always such as to repel the magnet, by Lenz Law.

(Image courtesy of Prof. John Belcher, MIT, USA)

Chapter 1

Fields

1.1	Action at a Distance versus Field Theory	1
1.2	Scalar Fields.....	2
	Example 1.1: Half-Frozen /Half-Baked Planet.....	4
1.2.1	Representations of a Scalar Field.....	4
1.3	Vector Fields.....	6
1.4	Fluid Flow.....	7
	Animation 1.1: Sources and Sinks.....	7
	Animation 1.2: Circulations	9
1.4.1	Relationship Between Fluid Fields and Electromagnetic Fields	11
1.5	Gravitational Field.....	11
1.6	Electric Fields	13
1.7	Magnetic Field.....	14
1.8	Representations of a Vector Field.....	15
1.8.1	Vector Field Representation	15
1.8.2	Field Line Representation.....	16
1.8.3	Grass Seeds and Iron Filings Representations.....	17
1.8.4	Motion of Electric and Magnetic Field Lines.....	18
1.9	Summary.....	18
1.10	Solved Problems	19
1.10.1	Vector Fields.....	19
1.10.2	Scalar Fields.....	21
1.11	Additional Problems	22
1.11.1	Plotting Vector Fields.....	22
1.11.2	Position Vector in Spherical Coordinates.....	22
1.11.3	Electric Field.....	22
1.11.4	An Object Moving in a Circle.....	22
1.11.5	Vector Fields.....	23
1.11.6	Object Moving in Two Dimensions.....	23
1.11.7	Law of Cosines	24
1.11.8	Field Lines	24

Fields

1.1 Action at a Distance versus Field Theory

“... In order therefore to appreciate the requirements of the science [of electromagnetism], the student must make himself familiar with a considerable body of most intricate mathematics, the mere retention of which in the memory materially interferes with further progress ...”

James Clerk Maxwell [1855]

Classical electromagnetic field theory emerged in more or less complete form in 1873 in James Clerk Maxwell's *A Treatise on Electricity and Magnetism*. Maxwell based his theory in large part on the intuitive insights of Michael Faraday. The wide acceptance of Maxwell's theory has caused a fundamental shift in our understanding of physical reality. In this theory, electromagnetic fields are the mediators of the interaction between material objects. This view differs radically from the older “action at a distance” view that preceded field theory.

What is “action at a distance?” It is a worldview in which the interaction of two material objects requires no mechanism other than the objects themselves and the empty space between them. That is, two objects exert a force on each other simply because they are present. Any mutual force between them (for example, gravitational attraction or electric repulsion) is instantaneously transmitted from one object to the other through empty space. There is no need to take into account any method or agent of transmission of that force, or any finite speed for the propagation of that agent of transmission. This is known as “action at a distance” because objects exert forces on one another (“action”) with nothing but empty space (“distance”) between them. No other agent or mechanism is needed.

Many natural philosophers objected to the “action at a distance” model because in our everyday experience, forces are exerted by one object on another only when the objects are in direct contact. In the field theory view, this is always true in some sense. That is, objects that are not in direct contact (objects separated by apparently empty space) must exert a force on one another *through the presence of an intervening medium or mechanism existing in the space between the objects*.

The force between the two objects is transmitted by direct “contact” from the first object to an intervening mechanism immediately surrounding that object, and then from one element of space to a neighboring element, in a continuous manner, until the force is transmitted to the region of space contiguous to the second object, and thus ultimately to the second object itself.

Although the two objects are not in direct contact with one another, they are in direct contact with a medium or mechanism that exists between them. The force between the objects is transmitted (at a finite speed) by stresses induced in the intervening space by the presence of the objects. The “field theory” view thus avoids the concept of “action at a distance” and replaces it by the concept of “action by continuous contact.” The “contact” is provided by a stress, or “field,” induced in the space between the objects by their presence.

This is the essence of field theory, and is the foundation of all modern approaches to understanding the world around us. Classical electromagnetism was the first field theory. It involves many concepts that are mathematically complex. As a result, even now it is difficult to appreciate. In this first chapter of your introduction to field theory, we discuss what a *field* is, and how we represent fields. We begin with scalar fields.

1.2 Scalar Fields

A *scalar field* is a function that gives us a single value of some variable for every point in space. As an example, the image in Figure 1.2.1 shows the nighttime temperatures measured by the Thermal Emission Spectrometer instrument on the Mars Global Surveyor (MGS). The data were acquired during the first 500 orbits of the MGS mapping mission. The coldest temperatures, shown in purple, are -120°C while the warmest, shown in white, are -65°C .

The view is centered on Isidis Planitia (15N , 270W), which is covered with warm material, indicating a sandy and rocky surface. The small, cold (blue) circular region to the right is the area of the Elysium volcanoes, which are covered in dust that cools off rapidly at night. At this season the north polar region is in full sunlight and is relatively warm at night. It is winter in the southern hemisphere and the temperatures are extremely low.

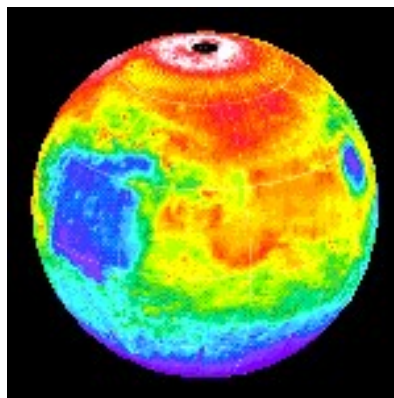

Figure 1.2.1 Nighttime temperature map for Mars

The various colors on the map represent the surface temperature. This map, however, is limited to representing only the temperature on a two-dimensional surface and thus, it does not show how temperature varies as a function of altitude. In principal, a scalar

field provides values not only on a two-dimensional surface in space but for every point in space.

Figure 1.2.2 illustrates the variation of temperature as a function of height above the surface of the Earth, which is a third dimension which complements the two dimensions shown in Figure 1.2.1.

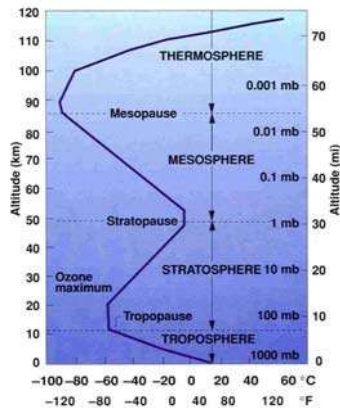

Figure 1.2.2 Atmospheric temperature variation as a function of altitude above the Earth's surface

How do we represent three-dimensional scalar fields? In principle, one could create a three-dimensional atmospheric volume element and color it to represent the temperature variation.

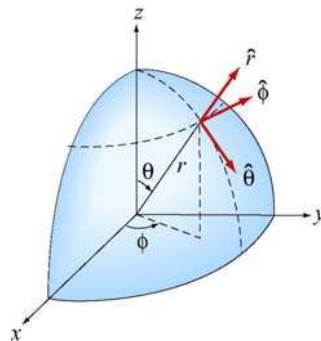

Figure 1.2.3 Spherical coordinates

Another way is to simply represent the temperature variation by a mathematical function. For the Earth we shall use spherical coordinates (r, θ, ϕ) shown in Figure 1.2.3 with the origin chosen to coincide with the center of the Earth. The temperature at any point is characterized by a function $T(r, \theta, \phi)$. In other words, the value of this function at the point with coordinates (r, θ, ϕ) is a temperature with given units. The temperature function $T(r, \theta, \phi)$ is an example of a “scalar field.” The term “scalar” implies that temperature at any point is a number rather than a vector (a vector has both magnitude and direction).

Example 1.1: Half-Frozen /Half-Baked Planet

As an example of a scalar field, consider a planet with an atmosphere that rotates with the same angular frequency about its axis as the planet orbits about a nearby star, *i.e.*, one hemisphere always faces the star. Let R denote the radius of the planet. Use spherical coordinates (r, θ, ϕ) with the origin at the center of the planet, and choose $\phi = \pi/2$ for the center of the hemisphere facing the star. A simplistic model for the temperature variation at any point is given by

$$T(r, \theta, \phi) = [T_0 + T_1 \sin^2 \theta + T_2(1 + \sin \phi)] e^{-\alpha(r-R)} \quad (1.2.1)$$

where T_0 , T_1 , T_2 , and α are constants. The dependence on the variable r in the term $e^{-\alpha(r-R)}$ indicates that the temperature decreases exponentially as we move radially away from the surface of the planet. The dependence on the variable θ in the term $\sin^2 \theta$ implies that the temperature decreases as we move toward the poles. Finally, the ϕ dependence in the term $(1 + \sin \phi)$ indicates that the temperature decreases as we move away from the center of the hemisphere facing the star.

A scalar field can also be used to describe other physical quantities such as the atmospheric pressure. However, a single number (magnitude) at every point in space is not sufficient to characterize quantities such as the wind velocity since a direction at every point in space is needed as well.

1.2.1 Representations of a Scalar Field

A field, as stated earlier, is a function that has a different value at every point in space. A scalar field is a field for which there is a single number associated with every point in space. We have seen that the temperature of the Earth's atmosphere at the surface is an example of a scalar field. Another example is

$$\phi(x, y, z) = \frac{1}{\sqrt{x^2 + (y+d)^2 + z^2}} - \frac{1/3}{\sqrt{x^2 + (y-d)^2 + z^2}} \quad (1.2.2)$$

This expression defines the value of the scalar function ϕ at every point (x, y, z) in space. How do visually represent a scalar field defined by an equation such as Eq. (1.2.2)? Below we discuss three possible representations.

1. Contour Maps

One way is to fix one of our independent variables (z , for example) and then show a contour map for the two remaining dimensions, in which the curves represent lines of constant values of the function ϕ . A series of these maps for various (fixed) values of z

then will give a feel for the properties of the scalar function. We show such a contour map in the xy -plane at $z = 0$ for Eq. (1.2.2), namely,

$$\phi(x, y, 0) = \frac{1}{\sqrt{x^2 + (y+d)^2}} - \frac{1/3}{\sqrt{x^2 + (y-d)^2}} \quad (1.2.3)$$

Various contour levels are shown in Figure 1.2.4, for $d = 1$, labeled by the value of the function at that level.

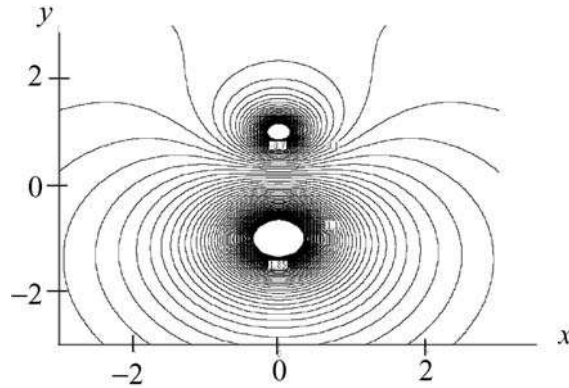

Figure 1.2.4 A contour map in the xy -plane of the scalar field given by Eq. (1.2.3).

2. Color-Coding

Another way we can represent the values of the scalar field is by color-coding in two dimensions for a fixed value of the third. This was the scheme used for illustrating the temperature fields in Figures 1.2.1 and 1.2.2. In Figure 1.2.5 a similar map is shown for the scalar field $\phi(x, y, 0)$. Different values of $\phi(x, y, 0)$ are characterized by different colors in the map.

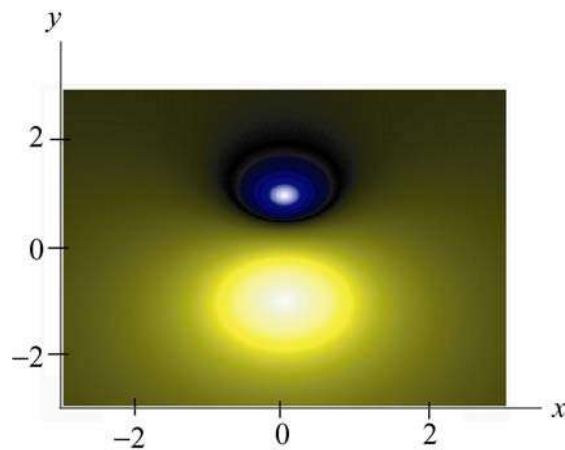

Figure 1.2.5 A color-coded map in the xy -plane of the scalar field given by Eq. (1.2.3).

3. Relief Maps

A third way to represent a scalar field is to fix one of the dimensions, and then plot the value of the function as a height versus the remaining spatial coordinates, say x and y , that is, as a relief map. Figure 1.2.6 shows such a map for the same function $\phi(x, y, 0)$.

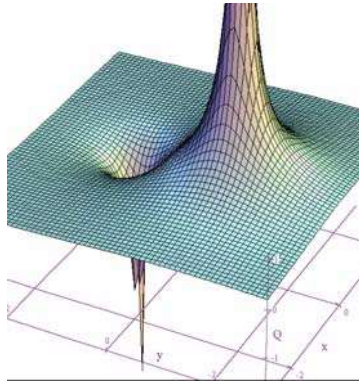

Figure 1.2.6 A relief map of the scalar field given by Eq. (1.2.3).

1.3 Vector Fields

A vector is a quantity which has both a magnitude and a direction in space. Vectors are used to describe physical quantities such as velocity, momentum, acceleration and force, associated with an object. However, when we try to describe a system which consists of a large number of objects (e.g., moving water, snow, rain,...) we need to assign a vector to each individual object.

As an example, let's consider falling snowflakes, as shown in Figure 1.3.1. As snow falls, each snowflake moves in a specific direction. The motion of the snowflakes can be analyzed by taking a series of photographs. At any instant in time, we can assign, to each snowflake, a velocity vector which characterizes its movement.

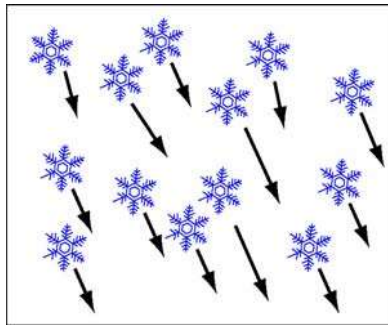

Figure 1.3.1 Falling snow.

The falling snow is an example of a collection of discrete bodies. On the other hand, if we try to analyze the motion of continuous bodies such as fluids, a velocity vector then needs to be assigned to every point in the fluid at any instant in time. Each vector describes the direction and magnitude of the velocity at a particular point and time. The collection of all the velocity vectors is called the velocity vector field. An important distinction between a vector field and a scalar field is that the former contains information about both the direction and the magnitude at every point in space, while only a single variable is specified for the latter. An example of a system of continuous bodies is air flow.

1.4 Fluid Flow

Animation 1.1: Sources and Sinks

In general, a vector field $\vec{F}(x, y, z)$ can be written as

$$\vec{F}(x, y, z) = F_x(x, y, z)\hat{i} + F_y(x, y, z)\hat{j} + F_z(x, y, z)\hat{k} \quad (1.4.1)$$

where the components are scalar fields. Below we use fluids to examine the properties associated with a vector field since fluid flows are the easiest vector fields to visualize.

In Figure 1.4.1 we show physical examples of a fluid flow field, where we represent the fluid by a finite number of particles to show the structure of the flow. In Figure 1.4.1(a), particles (fluid elements) appear at the center of a cone (a “source”) and then flow downward under the effect of gravity. That is, we create particles at the origin, and they subsequently flow away from their creation point. We also call this a diverging flow, since the particles appear to “diverge” from the creation point. Figure 1.4.1(b) is the converse of this, a converging flow, or a “sink” of particles.

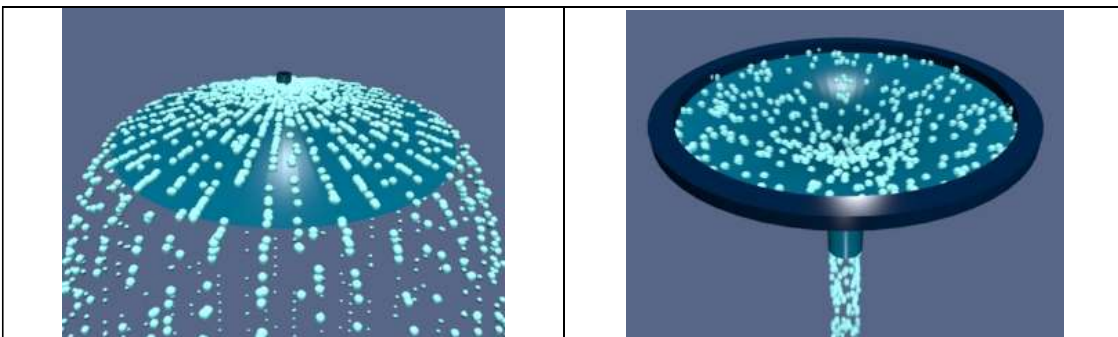

Figure 1.4.1 (a) An example of a source of particles and the flow associated with a source, (b) An example of a sink of particles and the flow associated with a sink.

Another representation of a diverging flow is in depicted in Figure 1.4.2.

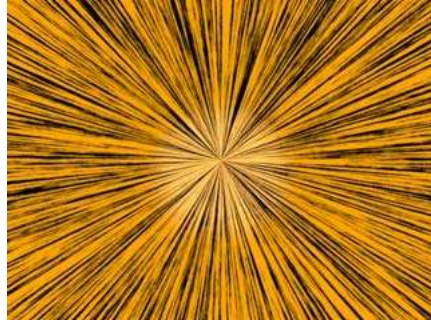

Figure 1.4.2 Representing the flow field associated with a source using textures.

Here the direction of the flow is represented by a texture pattern in which the direction of correlation in the texture is along the field direction.

Figure 1.4.3(a) shows a source next to a sink of lesser magnitude, and Figure 1.4.3(b) shows two sources of unequal strength.

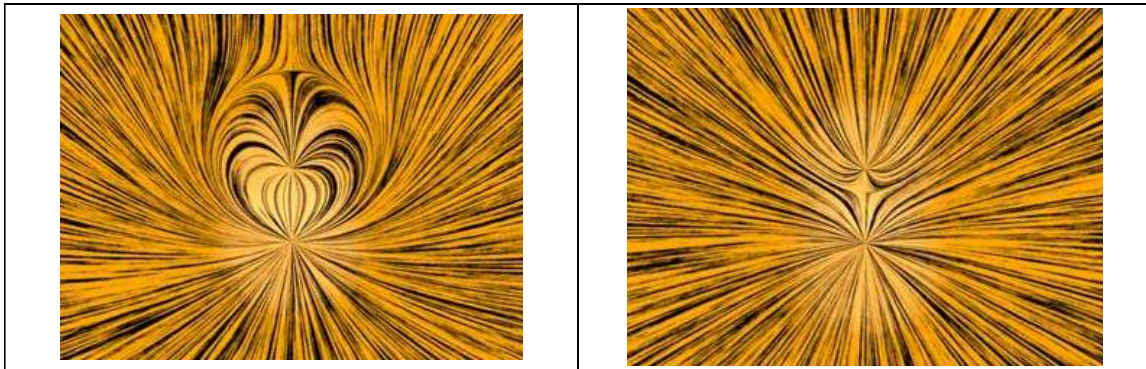

Figure 1.4.3 The flow fields associated with (a) a source (lower) and a sink (upper) where the sink is smaller than the source, and (b) two sources of unequal strength.

Finally, in Figure 1.4.4, we illustrate a constant downward flow interacting with a diverging flow (source). The diverging flow is able to make some headway “upwards” against the downward constant flow, but eventually turns and flows downward, overwhelmed by the strength of the “downward” flow.



Figure 1.4.4 A constant downward flow interacting with a diverging flow (source).
 In the language of vector calculus, we represent the flow field of a fluid by

$$\vec{v} = v_x \hat{i} + v_y \hat{j} + v_z \hat{k} \quad (1.4.2)$$

A point (x, y, z) is a source if the divergence of $\vec{v}(x, y, z)$ is greater than zero. That is,

$$\nabla \cdot \vec{v}(x, y, z) = \frac{\partial v_x}{\partial x} + \frac{\partial v_y}{\partial y} + \frac{\partial v_z}{\partial z} > 0 \quad (1.4.3)$$

where

$$\nabla = \frac{\partial}{\partial x} \hat{i} + \frac{\partial}{\partial y} \hat{j} + \frac{\partial}{\partial z} \hat{k} \quad (1.4.4)$$

is the del operator. On the other hand, (x, y, z) is a sink if the divergence of $\vec{v}(x, y, z)$ is less than zero. When $\nabla \cdot \vec{v}(x, y, z) = 0$, then the point (x, y, z) is neither a source nor a sink. A fluid whose flow field has zero divergence is said to be *incompressible*.

Animation 1.2: Circulations

A flow field which is neither a source nor a sink may exhibit another class of behavior - circulation. In Figure 1.4.5(a) we show a physical example of a circulating flow field where particles are not created or destroyed (except at the beginning of the animation), but merely move in circles. The purely circulating flow can also be represented by textures, as shown in Figure 1.4.5(b).

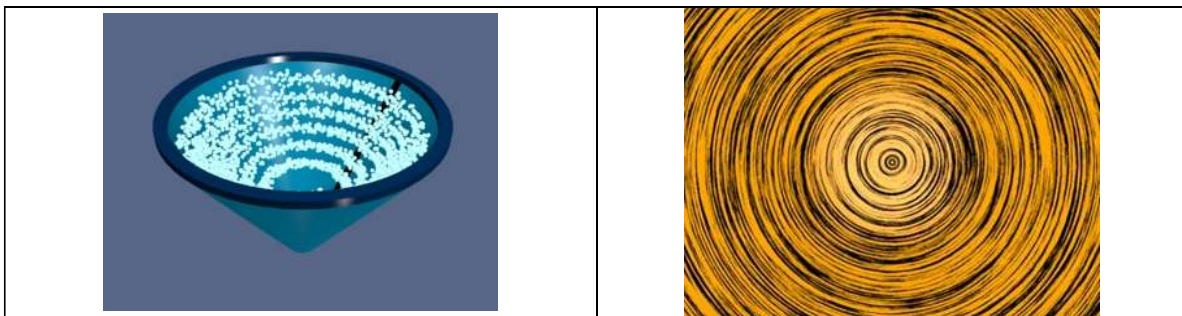

Figure 1.4.5 (a) An example of a circulating fluid. (b) Representing a circulating flow using textures.

A flow field can have more than one system of circulation centered about different points in space. In Figure 1.4.6(a) we show a flow field with two circulations. The flows are in opposite senses, and one of the circulations is stronger than the other. In Figure 1.4.6(b) we have the same situation, except that now the two circulations are in the same sense.



Figure 1.4.6 A flow with two circulation centers with (a) opposite directions of circulation. (b) the same direction of circulation

In Figure 1.4.7, we show a constant downward flow interacting with a counter-clockwise circulating flow. The circulating flow is able to make some headway against the downward constant flow, but eventually is overwhelmed by the strength of the “downward” flow.



Figure 1.4.7 A constant downward flow interacting with a counter-clockwise circulating flow.

In the language of vector calculus, the flows shown in Figures 1.4.5 through 1.4.7 are said to have a non-zero curl, but zero divergence. In contrast, the flows shown in Figures 1.4.2 through 1.4.4 have a zero curl (they do not move in circles) and a non-zero divergence (particles are created or destroyed).

Finally, in Figure 1.4.8, we show a fluid flow field that has both a circulation and a divergence (both the divergence and the curl of the vector field are non-zero). Any vector field can be written as the sum of a curl-free part (no circulation) and a divergence-free part (no source or sink). We will find in our study of electrostatics and magnetostatics that the electrostatic fields are curl free (e.g. they look like Figures 1.4.2 through 1.4.4) and the magnetic fields are divergence free (e.g. they look like Figures 1.4.5 and 1.4.6). Only when dealing with time-varying situations will we encounter electric fields that have both a divergence and a curl. Figure 1.4.8 depicts a field whose curl and divergence are non-vanishing. As far as we know even in time-varying situations magnetic fields always remain divergence-free. Therefore, magnetic fields will always look like the patterns shown in Figures 1.4.5 through 1.4.7.



Figure 1.4.8 A flow field that has both a source (divergence) and a circulation (curl).

1.4.1 Relationship Between Fluid Fields and Electromagnetic Fields

Vector fields that represent fluid flow have an immediate physical interpretation: the vector at every point in space represents a direction of motion of a fluid element, and we can construct animations of those fields, as above, which show that motion. A more general vector field, for example the electric and magnetic fields discussed below, do not have that immediate physical interpretation of a flow field. There is no “flow” of a fluid along an electric field or magnetic field.

However, even though the vectors in electromagnetism do not represent fluid flow, we carry over many of the terms we use to describe fluid flow to describe electromagnetic fields as well. For example we will speak of the flux (flow) of the electric field through a surface. If we were talking about fluid flow, “flux” would have a well-defined physical meaning, in that the flux would be the amount of fluid flowing across a given surface per unit time. There is no such meaning when we talk about the flux of the electric field through a surface, but we still use the same term for it, as if we were talking about fluid flow. Similarly we will find that magnetic vector field exhibit patterns like those shown above for circulating flows, and we will sometimes talk about the circulation of magnetic fields. But there is no fluid circulating along the magnetic field direction.

We use much of the terminology of fluid flow to describe electromagnetic fields because it helps us understand the structure of electromagnetic fields intuitively. However, we must always be aware that the analogy is limited.

1.5 Gravitational Field

The gravitational field of the Earth is another example of a vector field which can be used to describe the interaction between a massive object and the Earth. According to Newton’s universal law of gravitation, the gravitational force between two masses m and M is given by

$$\vec{\mathbf{F}}_g = -G \frac{Mm}{r^2} \hat{\mathbf{r}} \quad (1.5.1)$$

where r is the distance between the two masses and $\hat{\mathbf{r}}$ is the unit vector located at the position of m that points from M towards m . The constant of proportionality is the gravitational constant $G = 6.67 \times 10^{-11} \text{ N} \cdot \text{m}^2 / \text{kg}^2$. Notice that the force is always attractive, with its magnitude being proportional to the inverse square of the distance between the masses.

As an example, if M is the mass of the Earth, the gravitational field $\vec{\mathbf{g}}$ at a point P in space, defined as the gravitational force per unit mass, can be written as

$$\vec{\mathbf{g}} = \lim_{m \rightarrow 0} \frac{\vec{\mathbf{F}}_g}{m} = -G \frac{M}{r^2} \hat{\mathbf{r}} \quad (1.5.2)$$

From the above expression, we see that the field is radial and points toward the center of the Earth, as shown in Figure 1.5.1.

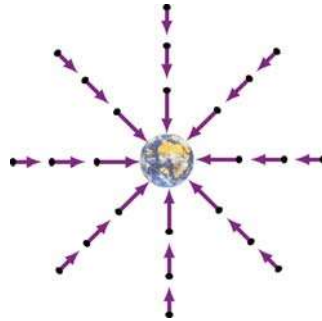

Figure 1.5.1 Gravitational field of the Earth.

Near the Earth's surface, the gravitational field $\vec{\mathbf{g}}$ is approximately constant: $\vec{\mathbf{g}} = -g\hat{\mathbf{r}}$, where

$$g = G \frac{M}{R_E^2} \approx 9.8 \text{ m/s}^2 \quad (1.5.3)$$

and R_E is the radius of Earth. The gravitational field near the Earth's surface is depicted in Figure 1.5.2.

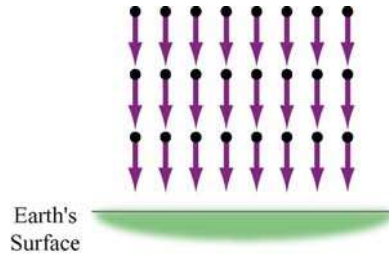

Figure 1.5.2 Uniform gravitational field near the surface of the Earth.

Notice that a mass in a constant gravitational field does not necessarily move in the direction of the field. This is true only when its initial velocity is in the same direction as the field. On the other hand, if the initial velocity has a component perpendicular to the gravitational field, the trajectory will be parabolic.

1.6 Electric Fields

The interaction between electric charges at rest is called the electrostatic force. However, unlike mass in gravitational force, there are two types of electric charge: positive and negative. Electrostatic force between charges falls off as the inverse square of their distance of separation, and can be either attractive or repulsive. Electric charges exert forces on each other in a manner that is analogous to gravitation. Consider an object which has charge Q . A “test charge” that is placed at a point P a distance r from Q will experience a Coulomb force:

$$\vec{F}_e = k_e \frac{Qq}{r^2} \hat{r} \quad (1.6.1)$$

where \hat{r} is the unit vector that points from Q to q . The constant of proportionality $k_e = 9.0 \times 10^9 \text{ N} \cdot \text{m}^2 / \text{C}^2$ is called the Coulomb constant. The electric field at P is defined as

$$\vec{E} = \lim_{q \rightarrow 0} \frac{\vec{F}_e}{q} = k_e \frac{Q}{r^2} \hat{r} \quad (1.6.2)$$

The SI unit of electric field is newtons/coulomb (N/C). If Q is positive, its electric field points radially away from the charge; on the other hand, the field points radially inward if Q is negative (Figure 1.6.1). In terms of the field concept, we may say that the charge Q creates an electric field \vec{E} which exerts a force $\vec{F}_e = q\vec{E}$ on q .

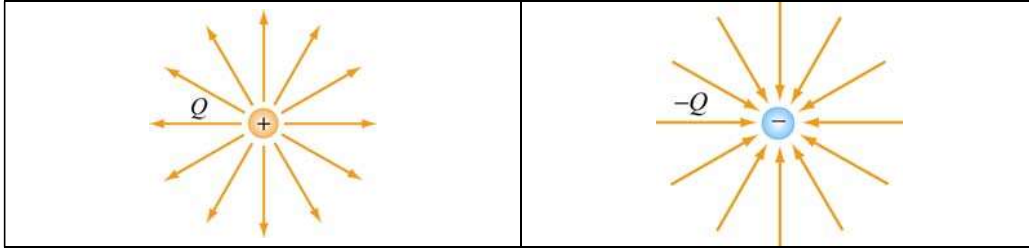

Figure 1.6.1 Electric field for positive and negative charges

1.7 Magnetic Field

Magnetic field is another example of a vector field. The most familiar source of magnetic fields is a bar magnet. One end of the bar magnet is called the North pole and the other, the South pole. Like poles repel while opposite poles attract (Figure 1.7.1).

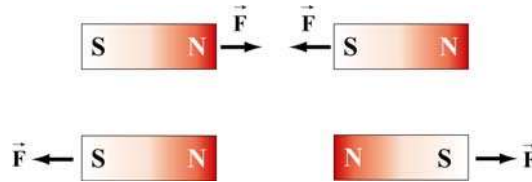

Figure 1.7.1 Magnets attracting and repelling

If we place some compasses near a bar magnet, the needles will align themselves along the direction of the magnetic field, as shown in Figure 1.7.2.

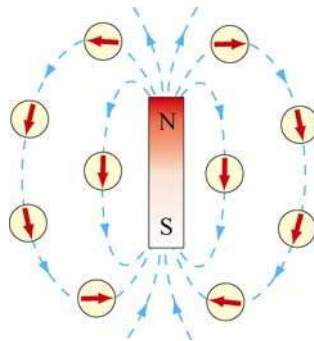

Figure 1.7.2 Magnetic field of a bar magnet

The observation can be explained as follows: A magnetic compass consists of a tiny bar magnet that can rotate freely about a pivot point passing through the center of the magnet. When a compass is placed near a bar magnet which produces an external magnetic field, it experiences a torque which tends to align the north pole of the compass with the external magnetic field.

The Earth’s magnetic field behaves as if there were a bar magnet in it (Figure 1.7.3). Note that the south pole of the magnet is located in the northern hemisphere.

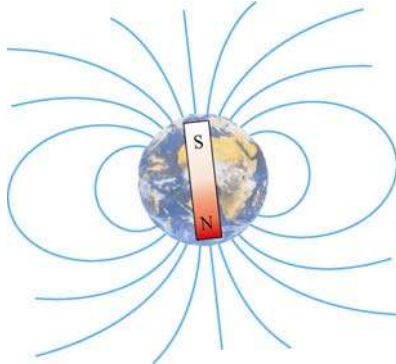

Figure 1.7.3 Magnetic field of the Earth

1.8 Representations of a Vector Field

How do we represent vector fields? Since there is much more information (magnitude and direction) in a vector field, our visualizations are correspondingly more complex when compared to the representations of scalar fields.

Let us introduce an analytic form for a vector field and discuss the various ways that we represent it. Let

$$\vec{\mathbf{E}}(x, y, z) = \frac{x\hat{\mathbf{i}} + (y + d)\hat{\mathbf{j}} + z\hat{\mathbf{k}}}{[x^2 + (y + d)^2 + z^2]^{3/2}} - \frac{1}{3} \frac{x\hat{\mathbf{i}} + (y - d)\hat{\mathbf{j}} + z\hat{\mathbf{k}}}{[x^2 + (y - d)^2 + z^2]^{3/2}} \quad (1.8.1)$$

This field is proportional to the electric field of two point charges of opposite signs, with the magnitude of the positive charge three times that of the negative charge. The positive charge is located at $(0, -d, 0)$ and the negative charge is located at $(0, d, 0)$. We discuss how this field is calculated in Section 2.7.

1.8.1 Vector Field Representation

Figure 1.8.1 is an example of a “vector field” representation of Eq. (1.8.1), in the plane where $z = 0$. We show the charges that would produce this field if it were an electric field, one positive (the orange charge) and one negative (the blue charge). We will always use this color scheme to represent positive and negative charges.

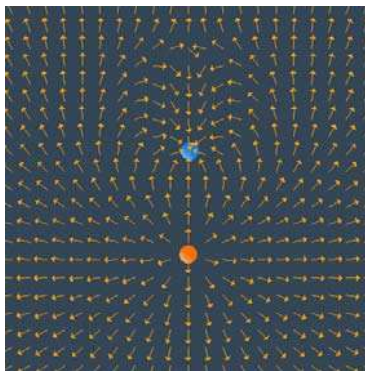

Figure 1.8.1 A “vector field” representation of the field of two point charges, one negative and one positive, with the magnitude of the positive charge three times that of the negative charge. In the applet linked to this figure, one can vary the magnitude of the charges and the spacing of the vector field grid, and move the charges about.

In the vector field representation, we put arrows representing the field direction on a rectangular grid. The direction of the arrow at a given location represents the direction of the vector field at that point. In many cases, we also make the length of the vector proportional to the magnitude of the vector field at that point. But we also may show only the direction with the vectors (that is make all vectors the same length), and color-code the arrows according to the magnitude of the vector. Or we may not give any information about the magnitude of the field at all, but just use the arrows on the grid to indicate the direction of the field at that point.

Figure 1.8.1 is an example of the latter situation. That is, we use the arrows on the vector field grid to simply indicate the direction of the field, with no indication of the magnitude of the field, either by the length of the arrows or their color. Note that the arrows point away from the positive charge (the positive charge is a “source” for electric field) and towards the negative charge (the negative charge is a “sink” for electric field).

1.8.2 Field Line Representation

There are other ways to represent a vector field. One of the most common is to draw “field lines.” Faraday called the field lines for electric field “lines of force.” To draw a field line, start out at any point in space and move a very short distance in the direction of the local vector field, drawing a line as you do so. After that short distance, stop, find the new direction of the local vector field at the point where you stopped, and begin moving again in that new direction. Continue this process indefinitely. Thereby you construct a line in space that is everywhere tangent to the local vector field. If you do this for different starting points, you can draw a set of field lines that give a good representation of the properties of the vector field. Figure 1.8.2 below is an example of a field line representation for the same two charges we used in Figure 1.8.1.

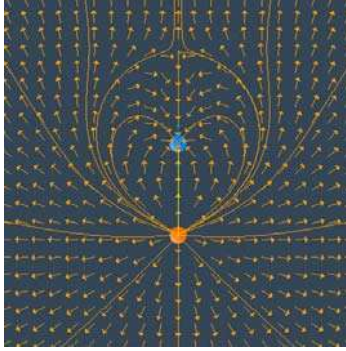

The field lines are everywhere tangent to the local field direction.

In summary, the field lines are a representation of the collection of vectors that constitute the field, and they are drawn according to the following rules:

- (1) The direction of the field line at any point in space is tangent to the field at that point.
- (2) The field lines never cross each other, otherwise there would be two different field directions at the point of intersection.

1.8.3 Grass Seeds and Iron Filings Representations

The final representation of vector fields is the “grass seeds” representation or the “iron filings” representation. For an electric field, this name derives from the fact that if you scatter grass seeds in a strong electric field, they will orient themselves with the long axis of the seed parallel to the local field direction. They thus provide a dense sampling of the shape of the field. Figure 1.8.4 is a “grass seeds” representation of the electric field for the same two charges in Figures 1.8.1 and 1.8.2.

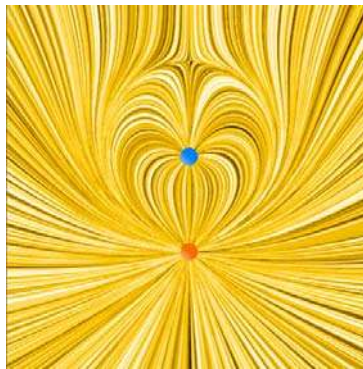

Figure 1.8.4: A “grass seeds” representation of the electric field that we considered in Figures 1.8.1 and 1.8.2. In the applet linked to this figure, one can generate “grass seeds” representations for different amounts of charge and different positions.

The local field direction is in the direction in which the texture pattern in this figure is correlated. This “grass seeds” representation gives by far the most information about the spatial structure of the field.

We will also use this technique to represent magnetic fields, but when used to represent magnetic fields we call it the “iron filings” representation. This name derives from the fact that if you scatter iron filings in a strong magnetic field, they will orient themselves with their long axis parallel to the local field direction. They thus provide a dense sampling of the shape of the magnetic field.

A frequent question from the student new to electromagnetism is “What is between the field lines?” Figures 1.8.2 and 1.8.4 make the answer to that question clear. What is between the field lines are more field lines that we have chosen not to draw. The field itself is a continuous feature of the space between the charges.

1.8.4 Motion of Electric and Magnetic Field Lines

In this course we will show the spatial structure of electromagnetic fields using all of the methods discussed above. In addition, for the field line and the grass seeds and iron filings representation, we will frequently show the time evolution of the fields. We do this by having the field lines and the grass seed patterns or iron filings patterns move in the direction of the energy flow in the electromagnetic field at a given point in space. The flow is in the direction of $\vec{E} \times \vec{B}$, the cross product of the electric field \vec{E} and the magnetic field \vec{B} , and is perpendicular to both \vec{E} and \vec{B} . This is very different from our representation of fluid flow fields above, where the direction of the flow is in the same direction as the velocity field itself. We will discuss the concept on energy flow in electromagnetic fields toward the end of the course.

We adopt this representation for time-changing electromagnetic fields because these fields can both support the flow of energy and can store energy as well. We will discuss quantitatively how to compute this energy flow later, when we discuss the Poynting vector in Chapter 13. For now we simply note that when we animate the motion of the field line or grass seeds or iron filings representations, the direction of the pattern motion indicates the direction in which energy in the electromagnetic field is flowing.

1.9 Summary

In this chapter, we have discussed the concept of fields. A scalar field $T(x, y, z)$ is a function on all the coordinates of space. Examples of a scalar field include temperature and pressure. On the other hand, a vector field $\vec{F}(x, y, z)$ is a vector each of whose components is a scalar field. A vector field $\vec{F}(x, y, z)$ has both magnitude and direction at every point (x, y, z) in space. Gravitational, electric and magnetic fields are all examples of vector fields.

1.10 Solved Problems

1.10.1 Vector Fields

Make a plot of the following vector fields:

(a) $\vec{v} = 3\hat{i} - 5\hat{j}$

This is an example of a constant vector field in two dimensions. The plot is depicted in Figure 1.10.1:

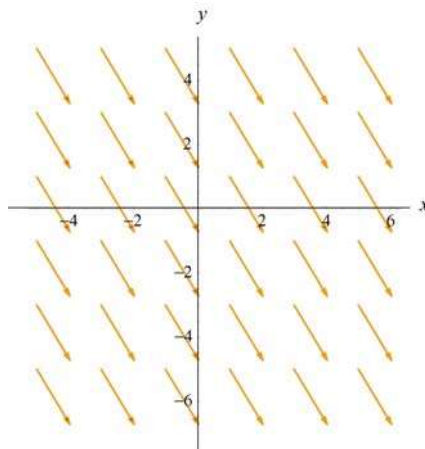

Figure 1.10.1

(b) $\vec{v} = \vec{r}$

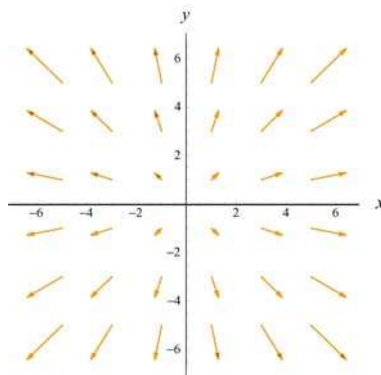

Figure 1.10.2

(c) $\vec{v} = \frac{\hat{r}}{r^2}$

In two dimensions, using the Cartesian coordinates where $\vec{r} = x\hat{i} + y\hat{j}$, \vec{v} can be written as

$$\vec{v} = \frac{\hat{r}}{r^2} = \frac{\vec{r}}{r^3} = \frac{x\hat{i} + y\hat{j}}{(x^2 + y^2)^{3/2}}$$

The plot is shown in Figure 1.10.3(a). Both the gravitational field of the Earth \vec{g} and the electric field \vec{E} due to a point charge have the same characteristic behavior as \vec{v} . In three dimensions where $\vec{r} = x\hat{i} + y\hat{j} + z\hat{k}$, the plot looks like that shown in Figure 1.10.3(b).

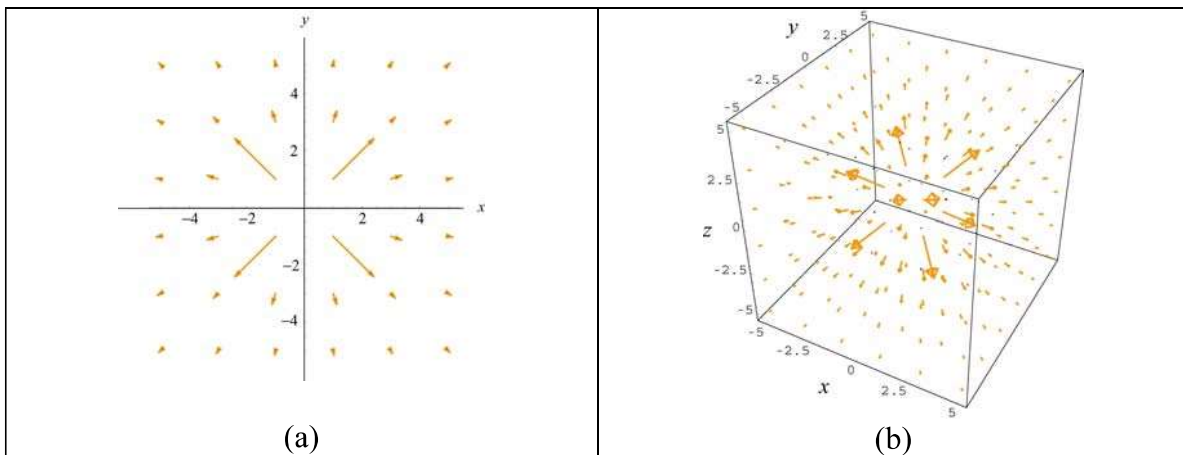

Figure 1.10.3

(d)
$$\vec{v} = \frac{3xy}{r^5}\hat{i} + \frac{2y^2 - x^2}{r^5}\hat{j}$$

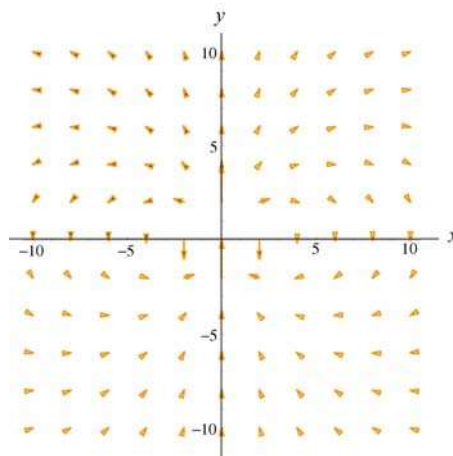

Figure 1.10.4

The plot is characteristic of the electric field due to a point electric dipole located at the origin.

1.10.2 Scalar Fields

Make a plot of the following scalar functions in two dimensions:

(a) $f(r) = \frac{1}{r}$

In two dimensions, we may write $r = \sqrt{x^2 + y^2}$.

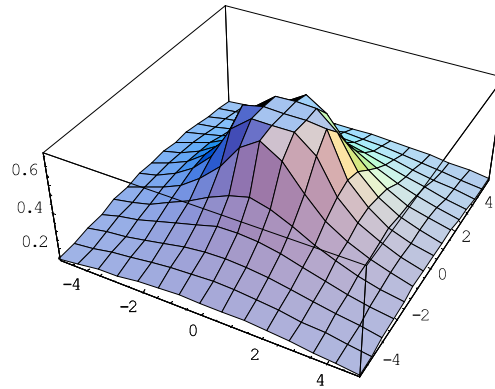

Figure 1.10.5

Figure 1.10.5 can be used to represent the electric potential due to a point charge located at the origin. Notice that the mesh size has been adjusted so that the singularity at $r = 0$ is not shown.

(b) $f(x, y) = \frac{1}{\sqrt{x^2 + (y-1)^2}} - \frac{1}{\sqrt{x^2 + (y+1)^2}}$

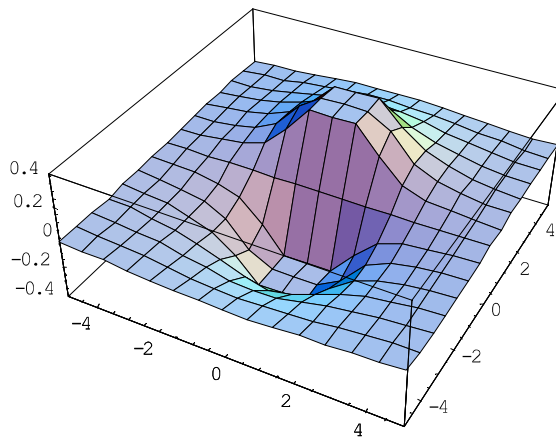

Figure 1.10.6

This plot represents the potential due to a dipole with the positive charge located

at $y = 1$ and the negative charge at $y = -1$. Again, singularities at $(x, y) = (0, \pm 1)$ are not shown.

1.11 Additional Problems

1.11.1 Plotting Vector Fields

Plot the following vector fields:

$$\begin{array}{llll}
 \text{(a)} \ y\hat{\mathbf{i}} - x\hat{\mathbf{j}} & \text{(b)} \ \frac{1}{\sqrt{2}}(\hat{\mathbf{i}} - \hat{\mathbf{j}}) & \text{(c)} \ \frac{x\hat{\mathbf{i}} + y\hat{\mathbf{j}}}{\sqrt{2}} & \text{(d)} \ 2y\hat{\mathbf{i}} \quad \text{(e)} \ x^2\hat{\mathbf{i}} + y^2\hat{\mathbf{j}} \\
 \text{(f)} \ \frac{y\hat{\mathbf{i}} - x\hat{\mathbf{j}}}{\sqrt{x^2 + y^2}} & \text{(g)} \ xy\hat{\mathbf{i}} - x\hat{\mathbf{j}} & \text{(h)} \ \cos x\hat{\mathbf{i}} + \sin y\hat{\mathbf{j}} &
 \end{array}$$

1.11.2 Position Vector in Spherical Coordinates

In spherical coordinates (see Figure 1.2.3), show that the position vector can be written as

$$\vec{\mathbf{r}} = r \sin \theta \cos \phi \hat{\mathbf{i}} + r \sin \theta \sin \phi \hat{\mathbf{j}} + r \cos \theta \hat{\mathbf{k}}$$

1.11.3 Electric Field

A charge $+1$ is situated at the point $(-1, 0, 0)$ and a charge -1 is situated at the point $(1, 0, 0)$. Find the electric field of these two charges at an arbitrary point $(0, y, 0)$ on the y -axis.

1.11.4 An Object Moving in a Circle

A particle moves in a circular path of radius r in the xy -plane with a constant angular speed $\omega = d\theta/dt$. At some instant t , the particle is at P , as shown in Figure 1.11.1.

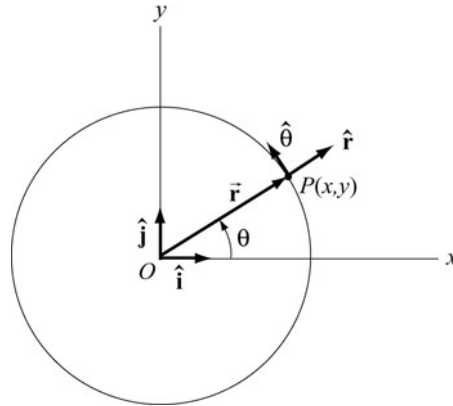

Figure 1.11.1

- Write down the position vector $\vec{r}(t)$.
- Calculate the velocity and acceleration of the particle at P .
- Express the unit vectors \hat{r} and $\hat{\theta}$ in polar coordinates in terms of the unit vectors \hat{i} and \hat{j} in Cartesian coordinates.

1.11.5 Vector Fields

- Find a vector field in two dimensions which points in the negative radial direction and has magnitude 1.
- Find a vector field in two dimensions which makes an angle of 45° with the x -axis and has a magnitude $(x + y)^2$ at any point (x, y) .
- Find a vector field in two dimensions whose direction is tangential and whose magnitude at any point (x, y) is equal to its distance from the origin.
- Find a vector field in three dimensions which is in the positive radial direction and whose magnitude is 1.

1.11.6 Object Moving in Two Dimensions

An object moving in two dimensions has a position vector

$$\vec{r}(t) = a \sin \omega t \hat{i} + b \cos \omega t \hat{j}$$

where a , b and ω are constants.

- How far is the object from the origin at time t ?

- (b) Find the velocity and acceleration as function of time for the object.
- (c) Show that the path of the object is elliptical.

1.11.7 Law of Cosines

Two sides of the triangle in Figure 1.11.2(a) form an angle θ . The sides have lengths a and b .

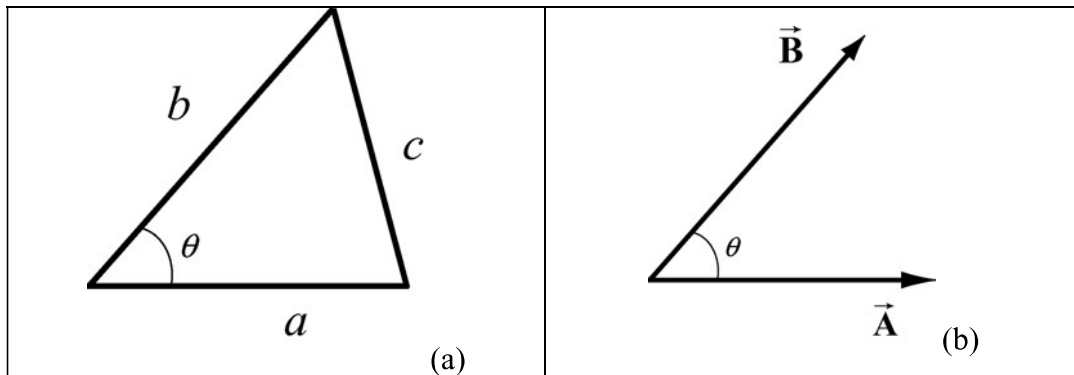

Figure 1.11.2 Law of cosines

The length of the side opposite θ is given by the relation triangle identity

$$c^2 = a^2 + b^2 - 2ab \cos \theta .$$

Suppose we describe the two given sides of the triangles by the vectors $\vec{\mathbf{A}}$ and $\vec{\mathbf{B}}$, with $|\vec{\mathbf{A}}| = a$ and $|\vec{\mathbf{B}}| = b$, as shown in Figure 1.11.2(b)

- (a) What is the geometric meaning of the vector $\vec{\mathbf{C}} = \vec{\mathbf{B}} - \vec{\mathbf{A}}$?
- (b) Show that the magnitude of $\vec{\mathbf{C}}$ is equal to the length of the opposite side of the triangle shown in Figure 1.11.2(a), that is, $|\vec{\mathbf{C}}| = c$.

1.11.8 Field Lines

A curve $y = y(x)$ is called a field line of the vector field $\vec{\mathbf{F}}(x, y)$ if at every point (x_0, y_0) on the curve, $\vec{\mathbf{F}}(x_0, y_0)$ is tangent to the curve (see Figure 1.11.3).

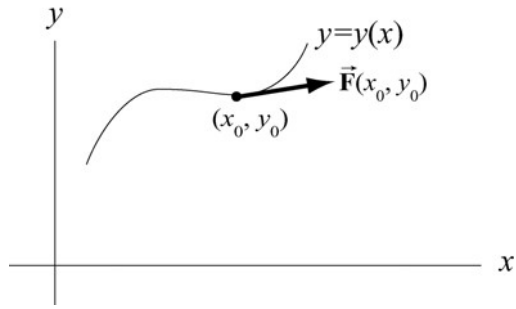

Figure 1.11.3

Show that the field lines $y = y(x)$ of a vector field $\vec{F}(x, y) = F_x(x, y)\hat{i} + F_y(x, y)\hat{j}$ represent the solutions of the differential equation

$$\frac{dy}{dx} = \frac{F_y(x, y)}{F_x(x, y)}$$

Chapter 2

Coulomb's Law

2.1	Electric Charge.....	2
2.2	Coulomb's Law	2
	Animation 2.1: Van de Graaff Generator	3
2.3	Principle of Superposition.....	4
	Example 2.1: Three Charges.....	4
2.4	Electric Field.....	6
	Animation 2.2: Electric Field of Point Charges	7
2.5	Electric Field Lines	8
2.6	Force on a Charged Particle in an Electric Field	9
2.7	Electric Dipole	10
	2.7.1 The Electric Field of a Dipole.....	11
	Animation 2.3: Electric Dipole.....	12
2.8	Dipole in Electric Field.....	12
	2.8.1 Potential Energy of an Electric Dipole	13
2.9	Charge Density.....	15
	2.9.1 Volume Charge Density.....	15
	2.9.2 Surface Charge Density	16
	2.9.3 Line Charge Density	16
2.10	Electric Fields due to Continuous Charge Distributions.....	17
	Example 2.2: Electric Field on the Axis of a Rod	17
	Example 2.3: Electric Field on the Perpendicular Bisector	18
	Example 2.4: Electric Field on the Axis of a Ring	20
	Example 2.5: Electric Field Due to a Uniformly Charged Disk.....	22
2.11	Summary	24
2.12	Problem-Solving Strategies	26
2.13	Solved Problems	28
	2.13.1 Hydrogen Atom	28
	2.13.2 Millikan Oil-Drop Experiment	29
	2.13.3 Charge Moving Perpendicularly to an Electric Field	30
	2.13.4 Electric Field of a Dipole.....	32
	2.13.5 Electric Field of an Arc.....	35
	2.13.6 Electric Field Off the Axis of a Finite Rod.....	36

2.14 Conceptual Questions	38
2.15 Additional Problems	39
2.15.1 Three Point Charges.....	39
2.15.2 Three Point Charges.....	39
2.15.3 Four Point Charges	40
2.15.4 Semicircular Wire	40
2.15.5 Electric Dipole	41
2.15.6 Charged Cylindrical Shell and Cylinder	41
2.15.7 Two Conducting Balls	42
2.15.8 Torque on an Electric Dipole.....	42

Coulomb's Law

2.1 Electric Charge

There are two types of observed electric charge, which we designate as positive and negative. The convention was derived from Benjamin Franklin's experiments. He rubbed a glass rod with silk and called the charges on the glass rod positive. He rubbed sealing wax with fur and called the charge on the sealing wax negative. Like charges repel and opposite charges attract each other. The unit of charge is called the Coulomb (C).

The smallest unit of "free" charge known in nature is the charge of an electron or proton, which has a magnitude of

$$e = 1.602 \times 10^{-19} \text{ C} \quad (2.1.1)$$

Charge of any ordinary matter is quantized in integral multiples of e . An electron carries one unit of negative charge, $-e$, while a proton carries one unit of positive charge, $+e$. In a closed system, the total amount of charge is conserved since charge can neither be created nor destroyed. A charge can, however, be transferred from one body to another.

2.2 Coulomb's Law

Consider a system of two point charges, q_1 and q_2 , separated by a distance r in vacuum. The force exerted by q_1 on q_2 is given by Coulomb's law:

$$\vec{F}_{12} = k_e \frac{q_1 q_2}{r^2} \hat{r} \quad (2.2.1)$$

where k_e is the Coulomb constant, and $\hat{r} = \vec{r}/r$ is a unit vector directed from q_1 to q_2 , as illustrated in Figure 2.2.1(a).

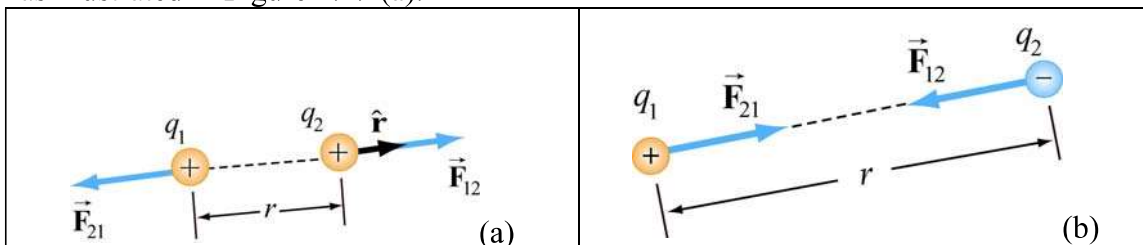

Figure 2.2.1 Coulomb interaction between two charges

Note that electric force is a vector which has both magnitude and direction. In SI units, the Coulomb constant k_e is given by

$$k_e = \frac{1}{4\pi\epsilon_0} = 8.9875 \times 10^9 \text{ N} \cdot \text{m}^2 / \text{C}^2 \quad (2.2.2)$$

where

$$\epsilon_0 = \frac{1}{4\pi(8.99 \times 10^9 \text{ N} \cdot \text{m}^2 / \text{C}^2)} = 8.85 \times 10^{-12} \text{ C}^2 / \text{N} \cdot \text{m}^2 \quad (2.2.3)$$

is known as the “permittivity of free space.” Similarly, the force on q_1 due to q_2 is given by $\vec{F}_{21} = -\vec{F}_{12}$, as illustrated in Figure 2.2.1(b). This is consistent with Newton's third law.

As an example, consider a hydrogen atom in which the proton (nucleus) and the electron are separated by a distance $r = 5.3 \times 10^{-11} \text{ m}$. The electrostatic force between the two particles is approximately $F_e = k_e e^2 / r^2 = 8.2 \times 10^{-8} \text{ N}$. On the other hand, one may show that the gravitational force is only $F_g \approx 3.6 \times 10^{-47} \text{ N}$. Thus, gravitational effect can be neglected when dealing with electrostatic forces!

Animation 2.1: Van de Graaff Generator

Consider Figure 2.2.2(a) below. The figure illustrates the repulsive force transmitted between two objects by their electric fields. The system consists of a charged metal sphere of a van de Graaff generator. This sphere is fixed in space and is not free to move. The other object is a small charged sphere that is free to move (we neglect the force of gravity on this sphere). According to Coulomb’s law, these two like charges repel each another. That is, the small sphere experiences a repulsive force away from the van de Graaff sphere.

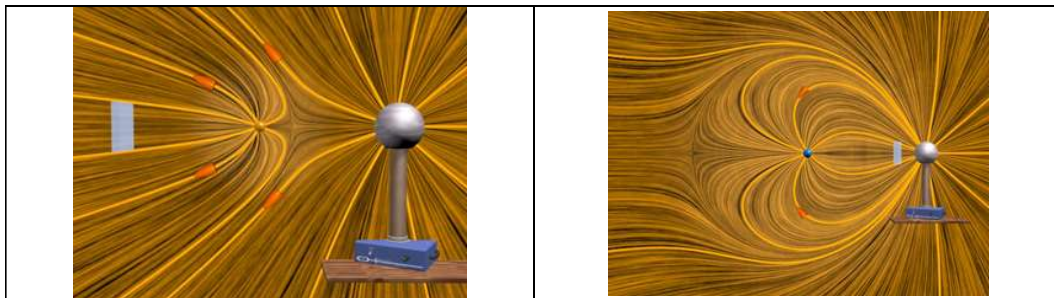

Figure 2.2.2 (a) Two charges of the same sign that repel one another because of the “stresses” transmitted by electric fields. We use both the “grass seeds” representation and the “field lines” representation of the electric field of the two charges. (b) Two charges of opposite sign that attract one another because of the stresses transmitted by electric fields.

The animation depicts the motion of the small sphere and the electric fields in this situation. Note that to repeat the motion of the small sphere in the animation, we have

the small sphere “bounce off” of a small square fixed in space some distance from the van de Graaff generator.

Before we discuss this animation, consider Figure 2.2.2(b), which shows one frame of a movie of the interaction of two charges with opposite signs. Here the charge on the small sphere is opposite to that on the van de Graaff sphere. By Coulomb’s law, the two objects now attract one another, and the small sphere feels a force attracting it toward the van de Graaff. To repeat the motion of the small sphere in the animation, we have that charge “bounce off” of a square fixed in space near the van de Graaff.

The point of these two animations is to underscore the fact that the Coulomb force between the two charges is *not* “action at a distance.” Rather, the stress is transmitted by direct “contact” from the van de Graaff to the immediately surrounding space, via the electric field of the charge on the van de Graaff. That stress is then transmitted from one element of space to a neighboring element, in a continuous manner, until it is transmitted to the region of space contiguous to the small sphere, and thus ultimately to the small sphere itself. Although the two spheres are not in direct contact with one another, they are in direct contact with a medium or mechanism that exists between them. The force between the small sphere and the van de Graaff is transmitted (at a finite speed) by stresses induced in the intervening space by their presence.

Michael Faraday invented field theory; drawing “lines of force” or “field lines” was his way of representing the fields. He also used his drawings of the lines of force to gain insight into the stresses that the fields transmit. He was the first to suggest that these fields, which exist continuously in the space between charged objects, transmit the stresses that result in forces between the objects.

2.3 Principle of Superposition

Coulomb’s law applies to any pair of point charges. When more than two charges are present, the net force on any one charge is simply the vector sum of the forces exerted on it by the other charges. For example, if three charges are present, the resultant force experienced by q_3 due to q_1 and q_2 will be

$$\vec{F}_3 = \vec{F}_{13} + \vec{F}_{23} \quad (2.3.1)$$

The superposition principle is illustrated in the example below.

Example 2.1: Three Charges

Three charges are arranged as shown in Figure 2.3.1. Find the force on the charge q_3 assuming that $q_1 = 6.0 \times 10^{-6} \text{ C}$, $q_2 = -q_1 = -6.0 \times 10^{-6} \text{ C}$, $q_3 = +3.0 \times 10^{-6} \text{ C}$ and $a = 2.0 \times 10^{-2} \text{ m}$.

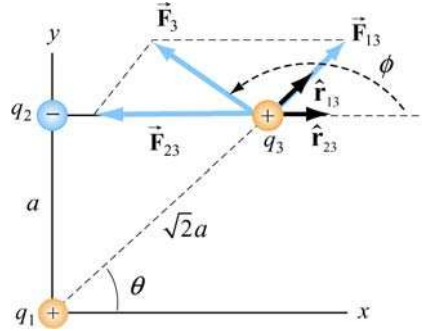

Figure 2.3.1 A system of three charges

Solution:

Using the superposition principle, the force on q_3 is

$$\vec{\mathbf{F}}_3 = \vec{\mathbf{F}}_{13} + \vec{\mathbf{F}}_{23} = \frac{1}{4\pi\epsilon_0} \left(\frac{q_1 q_3}{r_{13}^2} \hat{\mathbf{r}}_{13} + \frac{q_2 q_3}{r_{23}^2} \hat{\mathbf{r}}_{23} \right)$$

In this case the second term will have a negative coefficient, since q_2 is negative. The unit vectors $\hat{\mathbf{r}}_{13}$ and $\hat{\mathbf{r}}_{23}$ do not point in the same directions. In order to compute this sum, we can express each unit vector in terms of its Cartesian components and add the forces according to the principle of vector addition.

From the figure, we see that the unit vector $\hat{\mathbf{r}}_{13}$ which points from q_1 to q_3 can be written as

$$\hat{\mathbf{r}}_{13} = \cos \theta \hat{\mathbf{i}} + \sin \theta \hat{\mathbf{j}} = \frac{\sqrt{2}}{2} (\hat{\mathbf{i}} + \hat{\mathbf{j}})$$

Similarly, the unit vector $\hat{\mathbf{r}}_{23} = \hat{\mathbf{i}}$ points from q_2 to q_3 . Therefore, the total force is

$$\begin{aligned} \vec{\mathbf{F}}_3 &= \frac{1}{4\pi\epsilon_0} \left(\frac{q_1 q_3}{r_{13}^2} \hat{\mathbf{r}}_{13} + \frac{q_2 q_3}{r_{23}^2} \hat{\mathbf{r}}_{23} \right) = \frac{1}{4\pi\epsilon_0} \left(\frac{q_1 q_3}{(\sqrt{2}a)^2} \frac{\sqrt{2}}{2} (\hat{\mathbf{i}} + \hat{\mathbf{j}}) + \frac{(-q_1) q_3}{a^2} \hat{\mathbf{i}} \right) \\ &= \frac{1}{4\pi\epsilon_0} \frac{q_1 q_3}{a^2} \left[\left(\frac{\sqrt{2}}{4} - 1 \right) \hat{\mathbf{i}} + \frac{\sqrt{2}}{4} \hat{\mathbf{j}} \right] \end{aligned}$$

upon adding the components. The magnitude of the total force is given by

$$F_3 = \frac{1}{4\pi\epsilon_0} \frac{q_1 q_3}{a^2} \left[\left(\frac{\sqrt{2}}{4} - 1 \right)^2 + \left(\frac{\sqrt{2}}{4} \right)^2 \right]^{1/2}$$

$$= (9.0 \times 10^9 \text{ N} \cdot \text{m}^2 / \text{C}^2) \frac{(6.0 \times 10^{-6} \text{ C})(3.0 \times 10^{-6} \text{ C})}{(2.0 \times 10^{-2} \text{ m})^2} (0.74) = 3.0 \text{ N}$$

The angle that the force makes with the positive x -axis is

$$\phi = \tan^{-1} \left(\frac{F_{3,y}}{F_{3,x}} \right) = \tan^{-1} \left[\frac{\sqrt{2}/4}{-1 + \sqrt{2}/4} \right] = 151.3^\circ$$

Note there are two solutions to this equation. The second solution $\phi = -28.7^\circ$ is incorrect because it would indicate that the force has positive \hat{i} and negative \hat{j} components.

For a system of N charges, the net force experienced by the j th particle would be

$$\vec{F}_j = \sum_{\substack{i=1 \\ i \neq j}}^N \vec{F}_{ij} \quad (2.3.2)$$

where \vec{F}_{ij} denotes the force between particles i and j . The superposition principle implies that the net force between any two charges is independent of the presence of other charges. This is true if the charges are in fixed positions.

2.4 Electric Field

The electrostatic force, like the gravitational force, is a force that acts at a distance, even when the objects are not in contact with one another. To justify such the notion we rationalize action at a distance by saying that one charge creates a field which in turn acts on the other charge.

An electric charge q produces an electric field everywhere. To quantify the strength of the field created by that charge, we can measure the force a positive “test charge” q_0 experiences at some point. The electric field \vec{E} is defined as:

$$\vec{E} = \lim_{q_0 \rightarrow 0} \frac{\vec{F}_e}{q_0} \quad (2.4.1)$$

We take q_0 to be infinitesimally small so that the field q_0 generates does not disturb the “source charges.” The analogy between the electric field and the gravitational field $\vec{g} = \lim_{m_0 \rightarrow 0} \vec{F}_m / m_0$ is depicted in Figure 2.4.1.

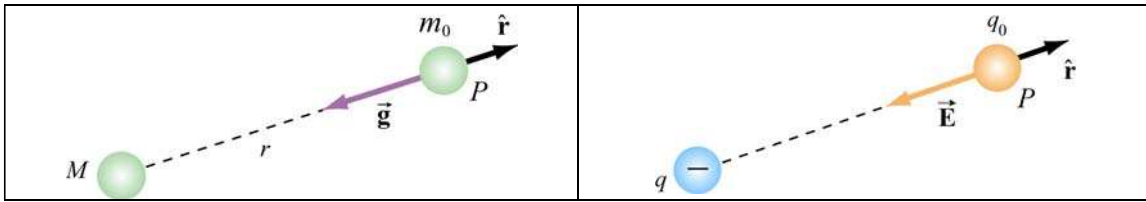

Figure 2.4.1 Analogy between the gravitational field \vec{g} and the electric field \vec{E} .

From the field theory point of view, we say that the charge q creates an electric field \vec{E} which exerts a force $\vec{F}_e = q_0 \vec{E}$ on a test charge q_0 .

Using the definition of electric field given in Eq. (2.4.1) and the Coulomb's law, the electric field at a distance r from a point charge q is given by

$$\vec{E} = \frac{1}{4\pi\epsilon_0} \frac{q}{r^2} \hat{r} \quad (2.4.2)$$

Using the superposition principle, the total electric field due to a group of charges is equal to the vector sum of the electric fields of individual charges:

$$\vec{E} = \sum_i \vec{E}_i = \sum_i \frac{1}{4\pi\epsilon_0} \frac{q_i}{r_i^2} \hat{r} \quad (2.4.3)$$

Animation 2.2: Electric Field of Point Charges

Figure 2.4.2 shows one frame of animations of the electric field of a moving positive and negative point charge, assuming the speed of the charge is small compared to the speed of light.

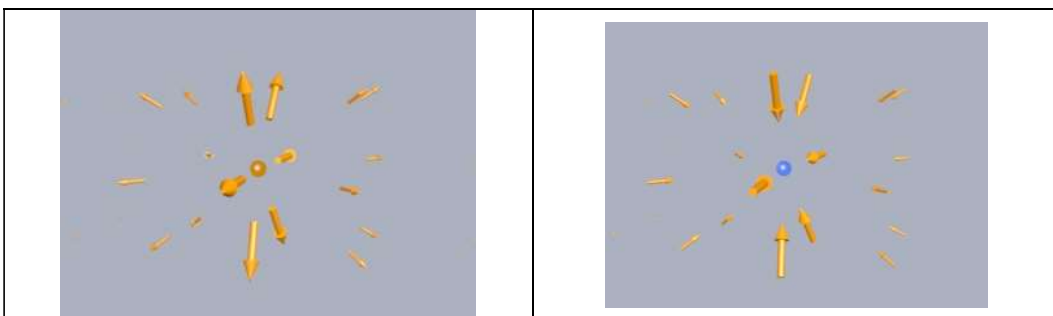

Figure 2.4.2 The electric fields of (a) a moving positive charge, (b) a moving negative charge, when the speed of the charge is small compared to the speed of light.

2.5 Electric Field Lines

Electric field lines provide a convenient graphical representation of the electric field in space. The field lines for a positive and a negative charges are shown in Figure 2.5.1.

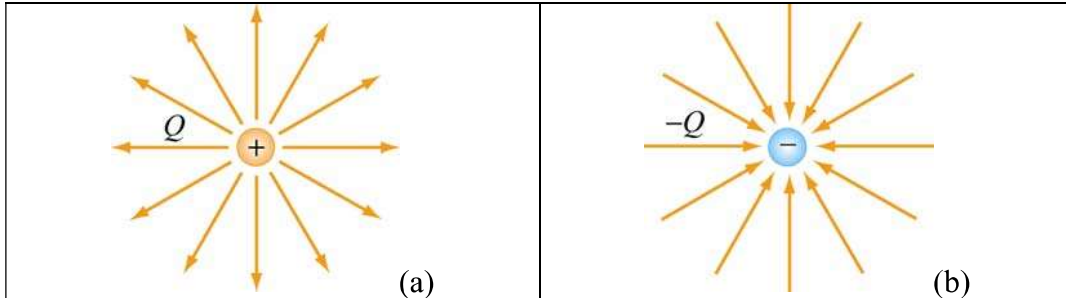

Figure 2.5.1 Field lines for (a) positive and (b) negative charges.

Notice that the direction of field lines is radially outward for a positive charge and radially inward for a negative charge. For a pair of charges of equal magnitude but opposite sign (an electric dipole), the field lines are shown in Figure 2.5.2.

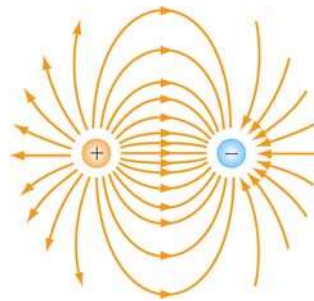

Figure 2.5.2 Field lines for an electric dipole.

The pattern of electric field lines can be obtained by considering the following:

(1) Symmetry: For every point above the line joining the two charges there is an equivalent point below it. Therefore, the pattern must be symmetrical about the line joining the two charges

(2) Near field: Very close to a charge, the field due to that charge predominates. Therefore, the lines are radial and spherically symmetric.

(3) Far field: Far from the system of charges, the pattern should look like that of a single point charge of value $Q = \sum_i Q_i$. Thus, the lines should be radially outward, unless $Q = 0$.

(4) Null point: This is a point at which $\vec{E} = \vec{0}$, and no field lines should pass through it.

The properties of electric field lines may be summarized as follows:

- The direction of the electric field vector \vec{E} at a point is tangent to the field lines.
- The number of lines per unit area through a surface perpendicular to the line is devised to be proportional to the magnitude of the electric field in a given region.
- The field lines must begin on positive charges (or at infinity) and then terminate on negative charges (or at infinity).
- The number of lines that originate from a positive charge or terminating on a negative charge must be proportional to the magnitude of the charge.
- No two field lines can cross each other; otherwise the field would be pointing in two different directions at the same point.

2.6 Force on a Charged Particle in an Electric Field

Consider a charge $+q$ moving between two parallel plates of opposite charges, as shown in Figure 2.6.1.

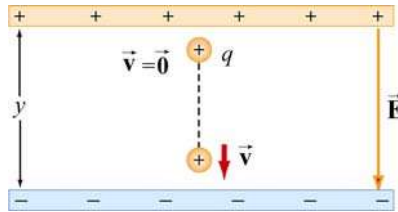

Figure 2.6.1 Charge moving in a constant electric field

Let the electric field between the plates be $\vec{E} = -E_y \hat{\mathbf{j}}$, with $E_y > 0$. (In Chapter 4, we shall show that the electric field in the region between two infinitely large plates of opposite charges is uniform.) The charge will experience a downward Coulomb force

$$\vec{F}_e = q\vec{E} \quad (2.6.1)$$

Note the distinction between the charge q that is experiencing a force and the charges on the plates that are the *sources* of the electric field. Even though the charge q is also a source of an electric field, by Newton's third law, the charge cannot exert a force on itself. Therefore, \vec{E} is the field that arises from the "source" charges only.

According to Newton's second law, a net force will cause the charge to accelerate with an acceleration

$$\vec{a} = \frac{\vec{F}_e}{m} = \frac{q\vec{E}}{m} = -\frac{qE_y}{m} \hat{j} \quad (2.6.2)$$

Suppose the particle is at rest ($v_0 = 0$) when it is first released from the positive plate. The final speed v of the particle as it strikes the negative plate is

$$v_y = \sqrt{2|a_y|y} = \sqrt{\frac{2yqE_y}{m}} \quad (2.6.3)$$

where y is the distance between the two plates. The kinetic energy of the particle when it strikes the plate is

$$K = \frac{1}{2}mv_y^2 = qE_y y \quad (2.6.4)$$

2.7 Electric Dipole

An electric dipole consists of two equal but opposite charges, $+q$ and $-q$, separated by a distance $2a$, as shown in Figure 2.7.1.

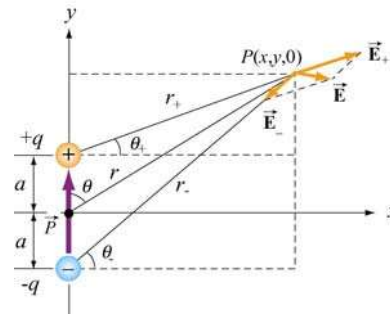

Figure 2.7.1 Electric dipole

The dipole moment vector \vec{p} which points from $-q$ to $+q$ (in the $+y$ -direction) is given by

$$\vec{p} = 2qa \hat{j} \quad (2.7.1)$$

The magnitude of the electric dipole is $p = 2qa$, where $q > 0$. For an overall charge-neutral system having N charges, the electric dipole vector \vec{p} is defined as

$$\vec{p} \equiv \sum_{i=1}^{i=N} q_i \vec{r}_i \quad (2.7.2)$$

where \vec{r}_i is the position vector of the charge q_i . Examples of dipoles include HCL, CO, H₂O and other *polar* molecules. In principle, any molecule in which the centers of the positive and negative charges do not coincide may be approximated as a dipole. In Chapter 5 we shall also show that by applying an external field, an electric dipole moment may also be induced in an unpolarized molecule.

2.7.1 The Electric Field of a Dipole

What is the electric field due to the electric dipole? Referring to Figure 2.7.1, we see that the x -component of the electric field strength at the point P is

$$E_x = \frac{q}{4\pi\epsilon_0} \left(\frac{\cos\theta_+}{r_+^2} - \frac{\cos\theta_-}{r_-^2} \right) = \frac{q}{4\pi\epsilon_0} \left(\frac{x}{[x^2 + (y-a)^2]^{3/2}} - \frac{x}{[x^2 + (y+a)^2]^{3/2}} \right) \quad (2.7.3)$$

where

$$r_{\pm}^2 = r^2 + a^2 \mp 2ra \cos\theta = x^2 + (y \mp a)^2 \quad (2.7.4)$$

Similarly, the y -component is

$$E_y = \frac{q}{4\pi\epsilon_0} \left(\frac{\sin\theta_+}{r_+^2} - \frac{\sin\theta_-}{r_-^2} \right) = \frac{q}{4\pi\epsilon_0} \left(\frac{y-a}{[x^2 + (y-a)^2]^{3/2}} - \frac{y+a}{[x^2 + (y+a)^2]^{3/2}} \right) \quad (2.7.5)$$

In the “point-dipole” limit where $r \gg a$, one may verify that (see Solved Problem 2.13.4) the above expressions reduce to

$$E_x = \frac{3p}{4\pi\epsilon_0 r^3} \sin\theta \cos\theta \quad (2.7.6)$$

and

$$E_y = \frac{P}{4\pi\epsilon_0 r^3} (3\cos^2\theta - 1) \quad (2.7.7)$$

where $\sin\theta = x/r$ and $\cos\theta = y/r$. With $3pr \cos\theta = 3\vec{p} \cdot \vec{r}$ and some algebra, the electric field may be written as

$$\vec{E}(\vec{r}) = \frac{1}{4\pi\epsilon_0} \left(-\frac{\vec{p}}{r^3} + \frac{3(\vec{p} \cdot \vec{r})\vec{r}}{r^5} \right) \quad (2.7.8)$$

Note that Eq. (2.7.8) is valid also in three dimensions where $\vec{r} = x\hat{i} + y\hat{j} + z\hat{k}$. The equation indicates that the electric field \vec{E} due to a dipole decreases with r as $1/r^3$,

unlike the $1/r^2$ behavior for a point charge. This is to be expected since the net charge of a dipole is zero and therefore must fall off more rapidly than $1/r^2$ at large distance. The electric field lines due to a finite electric dipole and a point dipole are shown in Figure 2.7.2.

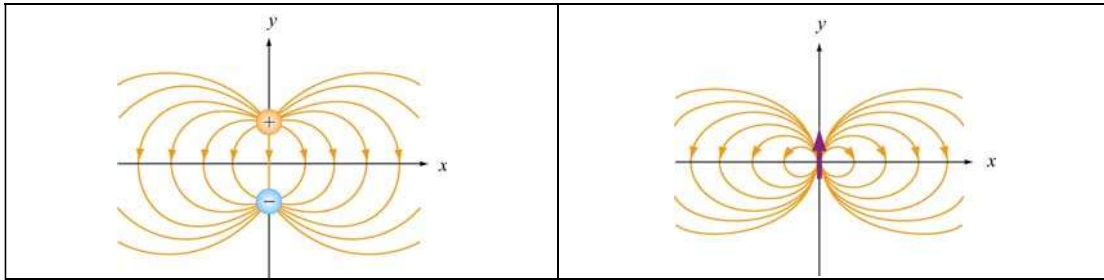

Figure 2.7.2 Electric field lines for (a) a finite dipole and (b) a point dipole.

Animation 2.3: Electric Dipole

Figure 2.7.3 shows an interactive ShockWave simulation of how the dipole pattern arises. At the observation point, we show the electric field due to each charge, which sum vectorially to give the total field. To get a feel for the total electric field, we also show a “grass seeds” representation of the electric field in this case. The observation point can be moved around in space to see how the resultant field at various points arises from the individual contributions of the electric field of each charge.

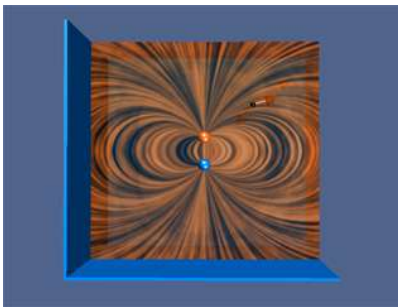

Figure 2.7.3 An interactive ShockWave simulation of the electric field of an two equal and opposite charges.

2.8 Dipole in Electric Field

What happens when we place an electric dipole in a uniform field $\vec{E} = E\hat{i}$, with the dipole moment vector \vec{p} making an angle with the x -axis? From Figure 2.8.1, we see that the unit vector which points in the direction of \vec{p} is $\cos\theta\hat{i} + \sin\theta\hat{j}$. Thus, we have

$$\vec{p} = 2qa(\cos\theta\hat{i} + \sin\theta\hat{j}) \quad (2.8.1)$$

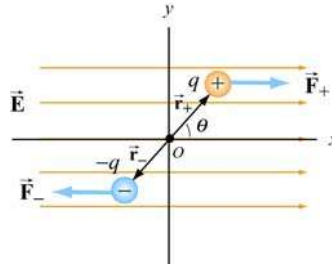

Figure 2.8.1 Electric dipole placed in a uniform field.

As seen from Figure 2.8.1 above, since each charge experiences an equal but opposite force due to the field, the net force on the dipole is $\vec{F}_{\text{net}} = \vec{F}_+ + \vec{F}_- = 0$. Even though the net force vanishes, the field exerts a torque on the dipole. The torque about the midpoint O of the dipole is

$$\begin{aligned}\vec{\tau} &= \vec{r}_+ \times \vec{F}_+ + \vec{r}_- \times \vec{F}_- = (a \cos \theta \hat{i} + a \sin \theta \hat{j}) \times (F_+ \hat{i}) + (-a \cos \theta \hat{i} - a \sin \theta \hat{j}) \times (-F_- \hat{i}) \\ &= a \sin \theta F_+ (-\hat{k}) + a \sin \theta F_- (-\hat{k}) \\ &= 2aF \sin \theta (-\hat{k})\end{aligned}\tag{2.8.2}$$

where we have used $F_+ = F_- = F$. The direction of the torque is $-\hat{k}$, or into the page. The effect of the torque $\vec{\tau}$ is to rotate the dipole *clockwise* so that the dipole moment \vec{p} becomes aligned with the electric field \vec{E} . With $F = qE$, the magnitude of the torque can be rewritten as

$$\tau = 2a(qE) \sin \theta = (2aq)E \sin \theta = pE \sin \theta$$

and the general expression for torque becomes

$$\vec{\tau} = \vec{p} \times \vec{E}\tag{2.8.3}$$

Thus, we see that the cross product of the dipole moment with the electric field is equal to the torque.

2.8.1 Potential Energy of an Electric Dipole

The work done by the electric field to rotate the dipole by an angle $d\theta$ is

$$dW = -\tau d\theta = -pE \sin \theta d\theta\tag{2.8.4}$$

The negative sign indicates that the torque *opposes* any increase in θ . Therefore, the total amount of work done by the electric field to rotate the dipole from an angle θ_0 to θ is

$$W = \int_{\theta_0}^{\theta} (-pE \sin \theta) d\theta = pE (\cos \theta - \cos \theta_0) \quad (2.8.5)$$

The result shows that a *positive* work is done by the field when $\cos \theta > \cos \theta_0$. The change in potential energy ΔU of the dipole is the negative of the work done by the field:

$$\Delta U = U - U_0 = -W = -pE (\cos \theta - \cos \theta_0) \quad (2.8.6)$$

where $U_0 = -pE \cos \theta_0$ is the potential energy at a reference point. We shall choose our reference point to be $\theta_0 = \pi/2$ so that the potential energy is zero there, $U_0 = 0$. Thus, in the presence of an external field the electric dipole has a potential energy

$$U = -pE \cos \theta = -\vec{p} \cdot \vec{E} \quad (2.8.7)$$

A system is at a stable equilibrium when its potential energy is a minimum. This takes place when the dipole \vec{p} is aligned parallel to \vec{E} , making U a minimum with $U_{\min} = -pE$. On the other hand, when \vec{p} and \vec{E} are anti-parallel, $U_{\max} = +pE$ is a maximum and the system is unstable.

If the dipole is placed in a non-uniform field, there would be a net force on the dipole in addition to the torque, and the resulting motion would be a combination of linear acceleration and rotation. In Figure 2.8.2, suppose the electric field \vec{E}_+ at $+q$ differs from the electric field \vec{E}_- at $-q$.

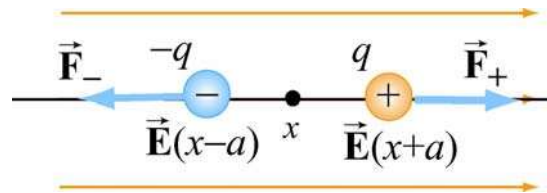

Figure 2.8.2 Force on a dipole

Assuming the dipole to be very small, we expand the fields about x :

$$E_+(x+a) \approx E(x) + a \left(\frac{dE}{dx} \right), \quad E_-(x-a) \approx E(x) - a \left(\frac{dE}{dx} \right) \quad (2.8.8)$$

The force on the dipole then becomes

$$\vec{\mathbf{F}}_e = q(\vec{\mathbf{E}}_+ - \vec{\mathbf{E}}_-) = 2qa \left(\frac{dE}{dx} \right) \hat{\mathbf{i}} = p \left(\frac{dE}{dx} \right) \hat{\mathbf{i}} \quad (2.8.9)$$

An example of a net force acting on a dipole is the attraction between small pieces of paper and a comb, which has been charged by rubbing against hair. The paper has *induced dipole moments* (to be discussed in depth in Chapter 5) while the field on the comb is non-uniform due to its irregular shape (Figure 2.8.3).

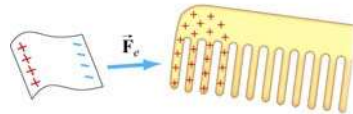

Figure 2.8.3 Electrostatic attraction between a piece of paper and a comb

2.9 Charge Density

The electric field due to a small number of charged particles can readily be computed using the superposition principle. But what happens if we have a very large number of charges distributed in some region in space? Let's consider the system shown in Figure 2.9.1:

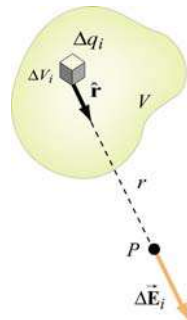

Figure 2.9.1 Electric field due to a small charge element Δq_i .

2.9.1 Volume Charge Density

Suppose we wish to find the electric field at some point P . Let's consider a small volume element ΔV_i which contains an amount of charge Δq_i . The distances between charges within the volume element ΔV_i are much smaller than compared to r , the distance between ΔV_i and P . In the limit where ΔV_i becomes infinitesimally small, we may define a volume charge density $\rho(\vec{\mathbf{r}})$ as

$$\rho(\vec{\mathbf{r}}) = \lim_{\Delta V_i \rightarrow 0} \frac{\Delta q_i}{\Delta V_i} = \frac{dq}{dV} \quad (2.9.1)$$

The dimension of $\rho(\vec{r})$ is charge/unit volume (C/m^3) in SI units. The total amount of charge within the entire volume V is

$$Q = \sum_i \Delta q_i = \int_V \rho(\vec{r}) dV \quad (2.9.2)$$

The concept of charge density here is analogous to mass density $\rho_m(\vec{r})$. When a large number of atoms are tightly packed within a volume, we can also take the continuum limit and the mass of an object is given by

$$M = \int_V \rho_m(\vec{r}) dV \quad (2.9.3)$$

2.9.2 Surface Charge Density

In a similar manner, the charge can be distributed over a surface S of area A with a *surface charge density* σ (lowercase Greek letter *sigma*):

$$\sigma(\vec{r}) = \frac{dq}{dA} \quad (2.9.4)$$

The dimension of σ is charge/unit area (C/m^2) in SI units. The total charge on the entire surface is:

$$Q = \iint_S \sigma(\vec{r}) dA \quad (2.9.5)$$

2.9.3 Line Charge Density

If the charge is distributed over a line of length ℓ , then the *linear charge density* λ (lowercase Greek letter *lambda*) is

$$\lambda(\vec{r}) = \frac{dq}{d\ell} \quad (2.9.6)$$

where the dimension of λ is charge/unit length (C/m). The total charge is now an integral over the entire length:

$$Q = \int_{\text{line}} \lambda(\vec{r}) d\ell \quad (2.9.7)$$

If charges are uniformly distributed throughout the region, the densities (ρ, σ or λ) then become uniform.

2.10 Electric Fields due to Continuous Charge Distributions

The electric field at a point P due to each charge element dq is given by Coulomb's law:

$$d\vec{E} = \frac{1}{4\pi\epsilon_0} \frac{dq}{r^2} \hat{r} \quad (2.10.1)$$

where r is the distance from dq to P and \hat{r} is the corresponding unit vector. (See Figure 2.9.1). Using the superposition principle, the total electric field \vec{E} is the vector sum (integral) of all these infinitesimal contributions:

$$\vec{E} = \frac{1}{4\pi\epsilon_0} \int_V \frac{dq}{r^2} \hat{r} \quad (2.10.2)$$

This is an example of a *vector* integral which consists of three separate integrations, one for each component of the electric field.

Example 2.2: Electric Field on the Axis of a Rod

A non-conducting rod of length ℓ with a uniform positive charge density λ and a total charge Q is lying along the x -axis, as illustrated in Figure 2.10.1.

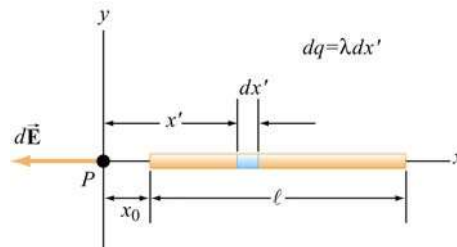

Figure 2.10.1 Electric field of a wire along the axis of the wire

Calculate the electric field at a point P located along the axis of the rod and a distance x_0 from one end.

Solution:

The linear charge density is uniform and is given by $\lambda = Q/\ell$. The amount of charge contained in a small segment of length dx' is $dq = \lambda dx'$.

Since the source carries a positive charge Q , the field at P points in the negative x direction, and the unit vector that points from the source to P is $\hat{\mathbf{r}} = -\hat{\mathbf{i}}$. The contribution to the electric field due to dq is

$$d\vec{\mathbf{E}} = \frac{1}{4\pi\epsilon_0} \frac{dq}{r^2} \hat{\mathbf{r}} = \frac{1}{4\pi\epsilon_0} \frac{\lambda dx'}{x'^2} (-\hat{\mathbf{i}}) = -\frac{1}{4\pi\epsilon_0} \frac{Q dx'}{\ell x'^2} \hat{\mathbf{i}}$$

Integrating over the entire length leads to

$$\vec{\mathbf{E}} = \int d\vec{\mathbf{E}} = -\frac{1}{4\pi\epsilon_0} \frac{Q}{\ell} \int_{x_0}^{x_0+\ell} \frac{dx'}{x'^2} \hat{\mathbf{i}} = -\frac{1}{4\pi\epsilon_0} \frac{Q}{\ell} \left(\frac{1}{x_0} - \frac{1}{x_0+\ell} \right) \hat{\mathbf{i}} = -\frac{1}{4\pi\epsilon_0} \frac{Q}{x_0(\ell+x_0)} \hat{\mathbf{i}} \quad (2.10.3)$$

Notice that when P is very far away from the rod, $x_0 \gg \ell$, and the above expression becomes

$$\vec{\mathbf{E}} \approx -\frac{1}{4\pi\epsilon_0} \frac{Q}{x_0^2} \hat{\mathbf{i}} \quad (2.10.4)$$

The result is to be expected since at sufficiently far distance away, the distinction between a continuous charge distribution and a point charge diminishes.

Example 2.3: Electric Field on the Perpendicular Bisector

A non-conducting rod of length ℓ with a uniform charge density λ and a total charge Q is lying along the x -axis, as illustrated in Figure 2.10.2. Compute the electric field at a point P , located at a distance y from the center of the rod along its perpendicular bisector.

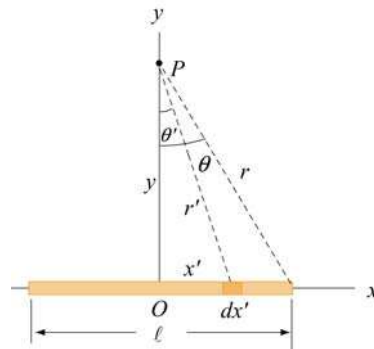

Figure 2.10.2

Solution:

We follow a similar procedure as that outlined in Example 2.2. The contribution to the electric field from a small length element dx' carrying charge $dq = \lambda dx'$ is

$$dE = \frac{1}{4\pi\epsilon_0} \frac{dq}{r'^2} = \frac{1}{4\pi\epsilon_0} \frac{\lambda dx'}{x'^2 + y^2} \quad (2.10.5)$$

Using symmetry argument illustrated in Figure 2.10.3, one may show that the x -component of the electric field vanishes.

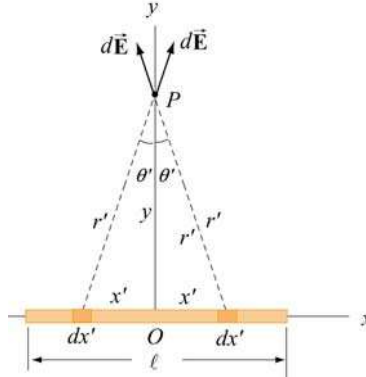

Figure 2.10.3 Symmetry argument showing that $E_x = 0$.

The y -component of dE is

$$dE_y = dE \cos \theta = \frac{1}{4\pi\epsilon_0} \frac{\lambda dx'}{x'^2 + y^2} \frac{y}{\sqrt{x'^2 + y^2}} = \frac{1}{4\pi\epsilon_0} \frac{\lambda y dx'}{(x'^2 + y^2)^{3/2}} \quad (2.10.6)$$

By integrating over the entire length, the total electric field due to the rod is

$$E_y = \int dE_y = \frac{1}{4\pi\epsilon_0} \int_{-\ell/2}^{\ell/2} \frac{\lambda y dx'}{(x'^2 + y^2)^{3/2}} = \frac{\lambda y}{4\pi\epsilon_0} \int_{-\ell/2}^{\ell/2} \frac{dx'}{(x'^2 + y^2)^{3/2}} \quad (2.10.7)$$

By making the change of variable: $x' = y \tan \theta'$, which gives $dx' = y \sec^2 \theta' d\theta'$, the above integral becomes

$$\begin{aligned} \int_{-\ell/2}^{\ell/2} \frac{dx'}{(x'^2 + y^2)^{3/2}} &= \int_{-\theta}^{\theta} \frac{y \sec^2 \theta' d\theta'}{y^3 (\sec^2 \theta' + 1)^{3/2}} = \frac{1}{y^2} \int_{-\theta}^{\theta} \frac{\sec^2 \theta' d\theta'}{(\tan^2 \theta' + 1)^{3/2}} = \frac{1}{y^2} \int_{-\theta}^{\theta} \frac{\sec^2 \theta' d\theta'}{\sec^3 \theta'} \\ &= \frac{1}{y^2} \int_{-\theta}^{\theta} \frac{d\theta'}{\sec \theta'} = \frac{1}{y^2} \int_{-\theta}^{\theta} \cos \theta' d\theta' = \frac{2 \sin \theta}{y^2} \end{aligned} \quad (2.10.8)$$

which gives

$$E_y = \frac{1}{4\pi\epsilon_0} \frac{2\lambda \sin \theta}{y} = \frac{1}{4\pi\epsilon_0} \frac{2\lambda}{y} \frac{\ell/2}{\sqrt{y^2 + (\ell/2)^2}} \quad (2.10.9)$$

In the limit where $y \gg \ell$, the above expression reduces to the “point-charge” limit:

$$E_y \approx \frac{1}{4\pi\epsilon_0} \frac{2\lambda \ell/2}{y^2} = \frac{1}{4\pi\epsilon_0} \frac{\lambda\ell}{y^2} = \frac{1}{4\pi\epsilon_0} \frac{Q}{y^2} \quad (2.10.10)$$

On the other hand, when $\ell \gg y$, we have

$$E_y \approx \frac{1}{4\pi\epsilon_0} \frac{2\lambda}{y} \quad (2.10.11)$$

In this infinite length limit, the system has cylindrical symmetry. In this case, an alternative approach based on Gauss’s law can be used to obtain Eq. (2.10.11), as we shall show in Chapter 4. The characteristic behavior of E_y/E_0 (with $E_0 = Q/4\pi\epsilon_0\ell^2$) as a function of y/ℓ is shown in Figure 2.10.4.

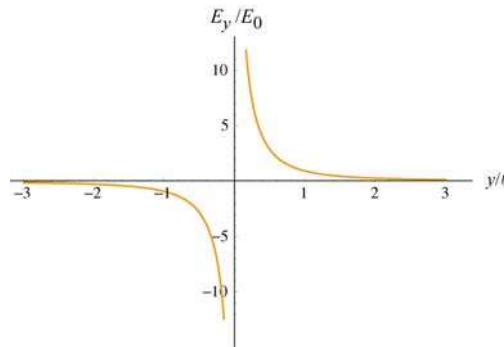

Figure 2.10.4 Electric field of a non-conducting rod as a function of y/ℓ .

Example 2.4: Electric Field on the Axis of a Ring

A non-conducting ring of radius R with a uniform charge density λ and a total charge Q is lying in the xy - plane, as shown in Figure 2.10.5. Compute the electric field at a point P , located at a distance z from the center of the ring along its axis of symmetry.

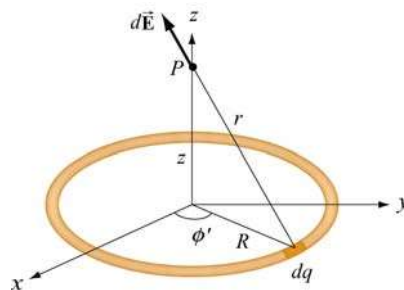

Figure 2.10.5 Electric field at P due to the charge element dq .

Solution:

Consider a small length element $d\ell'$ on the ring. The amount of charge contained within this element is $dq = \lambda d\ell' = \lambda R d\phi'$. Its contribution to the electric field at P is

$$d\vec{E} = \frac{1}{4\pi\epsilon_0} \frac{dq}{r^2} \hat{r} = \frac{1}{4\pi\epsilon_0} \frac{\lambda R d\phi'}{r^2} \hat{r} \quad (2.10.12)$$

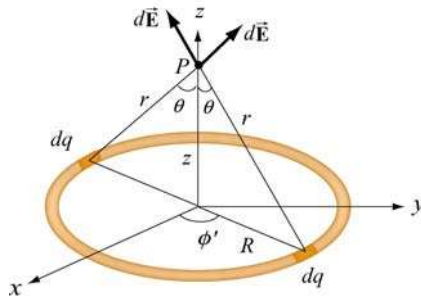

Figure 2.10.6

Using the symmetry argument illustrated in Figure 2.10.6, we see that the electric field at P must point in the $+z$ direction.

$$dE_z = dE \cos \theta = \frac{1}{4\pi\epsilon_0} \frac{\lambda R d\phi'}{R^2 + z^2} \frac{z}{\sqrt{R^2 + z^2}} = \frac{\lambda}{4\pi\epsilon_0} \frac{Rz d\phi'}{(R^2 + z^2)^{3/2}} \quad (2.10.13)$$

Upon integrating over the entire ring, we obtain

$$E_z = \frac{\lambda}{4\pi\epsilon_0} \frac{Rz}{(R^2 + z^2)^{3/2}} \oint d\phi' = \frac{\lambda}{4\pi\epsilon_0} \frac{2\pi Rz}{(R^2 + z^2)^{3/2}} = \frac{1}{4\pi\epsilon_0} \frac{Qz}{(R^2 + z^2)^{3/2}} \quad (2.10.14)$$

where the total charge is $Q = \lambda(2\pi R)$. A plot of the electric field as a function of z is given in Figure 2.10.7.

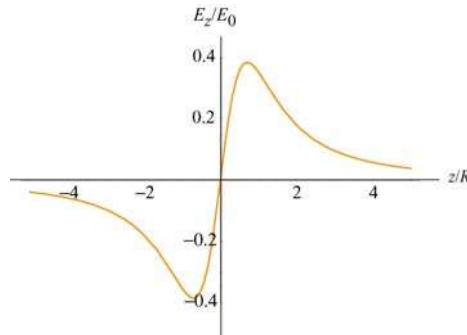

Figure 2.10.7 Electric field along the axis of symmetry of a non-conducting ring of radius R , with $E_0 = Q/4\pi\epsilon_0 R^2$.

Notice that the electric field at the center of the ring vanishes. This is to be expected from symmetry arguments.

Example 2.5: Electric Field Due to a Uniformly Charged Disk

A uniformly charged disk of radius R with a total charge Q lies in the xy -plane. Find the electric field at a point P , along the z -axis that passes through the center of the disk perpendicular to its plane. Discuss the limit where $R \gg z$.

Solution:

By treating the disk as a set of concentric uniformly charged rings, the problem could be solved by using the result obtained in Example 2.4. Consider a ring of radius r' and thickness dr' , as shown in Figure 2.10.8.

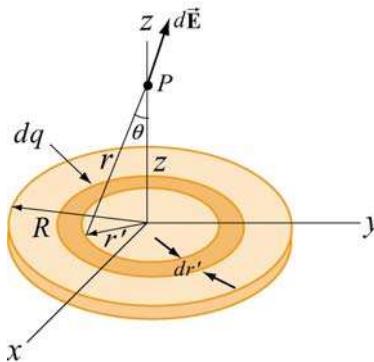

Figure 2.10.8 A uniformly charged disk of radius R .

By symmetry arguments, the electric field at P points in the $+z$ -direction. Since the ring has a charge $dq = \sigma(2\pi r' dr')$, from Eq. (2.10.14), we see that the ring gives a contribution

$$dE_z = \frac{1}{4\pi\epsilon_0} \frac{z dq}{(r'^2 + z^2)^{3/2}} = \frac{1}{4\pi\epsilon_0} \frac{z(2\pi\sigma r' dr')}{(r'^2 + z^2)^{3/2}} \quad (2.10.15)$$

Integrating from $r' = 0$ to $r' = R$, the total electric field at P becomes

$$\begin{aligned} E_z &= \int dE_z = \frac{\sigma z}{2\epsilon_0} \int_0^R \frac{r' dr'}{(r'^2 + z^2)^{3/2}} = \frac{\sigma z}{4\epsilon_0} \int_{z^2}^{R^2 + z^2} \frac{du}{u^{3/2}} = \frac{\sigma z}{4\epsilon_0} \frac{u^{-1/2}}{(-1/2)} \Big|_{z^2}^{R^2 + z^2} \\ &= -\frac{\sigma z}{2\epsilon_0} \left[\frac{1}{\sqrt{R^2 + z^2}} - \frac{1}{\sqrt{z^2}} \right] = \frac{\sigma}{2\epsilon_0} \left[\frac{z}{|z|} - \frac{z}{\sqrt{R^2 + z^2}} \right] \end{aligned} \quad (2.10.16)$$

The above equation may be rewritten as

$$E_z = \begin{cases} \frac{\sigma}{2\epsilon_0} \left[1 - \frac{z}{\sqrt{z^2 + R^2}} \right], & z > 0 \\ \frac{\sigma}{2\epsilon_0} \left[-1 - \frac{z}{\sqrt{z^2 + R^2}} \right], & z < 0 \end{cases} \quad (2.10.17)$$

The electric field E_z / E_0 ($E_0 = \sigma / 2\epsilon_0$) as a function of z / R is shown in Figure 2.10.9.

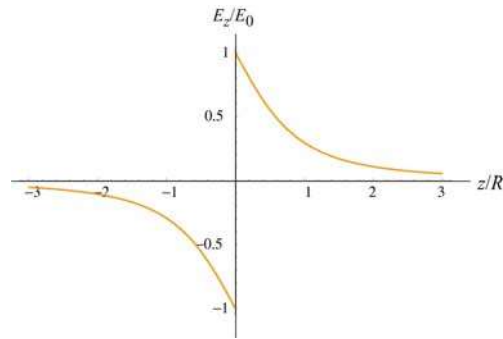

Figure 2.10.9 Electric field of a non-conducting plane of uniform charge density.

To show that the “point-charge” limit is recovered for $z \gg R$, we make use of the Taylor-series expansion:

$$1 - \frac{z}{\sqrt{z^2 + R^2}} = 1 - \left(1 + \frac{R^2}{z^2} \right)^{-1/2} = 1 - \left(1 - \frac{1}{2} \frac{R^2}{z^2} + \dots \right) \approx \frac{1}{2} \frac{R^2}{z^2} \quad (2.10.18)$$

This gives

$$E_z = \frac{\sigma}{2\epsilon_0} \frac{R^2}{2z^2} = \frac{1}{4\pi\epsilon_0} \frac{\sigma\pi R^2}{z^2} = \frac{1}{4\pi\epsilon_0} \frac{Q}{z^2} \quad (2.10.19)$$

which is indeed the expected “point-charge” result. On the other hand, we may also consider the limit where $R \gg z$. Physically this means that the plane is very large, or the field point P is extremely close to the surface of the plane. The electric field in this limit becomes, in unit-vector notation,

$$\vec{\mathbf{E}} = \begin{cases} \frac{\sigma}{2\epsilon_0} \hat{\mathbf{k}}, & z > 0 \\ -\frac{\sigma}{2\epsilon_0} \hat{\mathbf{k}}, & z < 0 \end{cases} \quad (2.10.20)$$

The plot of the electric field in this limit is shown in Figure 2.10.10.

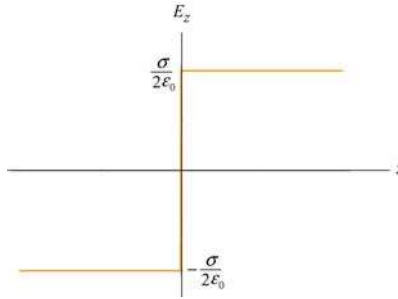

Figure 2.10.10 Electric field of an infinitely large non-conducting plane.

Notice the discontinuity in electric field as we cross the plane. The discontinuity is given by

$$\Delta E_z = E_{z+} - E_{z-} = \frac{\sigma}{2\epsilon_0} - \left(-\frac{\sigma}{2\epsilon_0} \right) = \frac{\sigma}{\epsilon_0} \quad (2.10.21)$$

As we shall see in Chapter 4, if a given surface has a charge density σ , then the normal component of the electric field across that surface always exhibits a discontinuity with $\Delta E_n = \sigma / \epsilon_0$.

2.11 Summary

- The electric force exerted by a charge q_1 on a second charge q_2 is given by **Coulomb's law**:

$$\vec{\mathbf{F}}_{12} = k_e \frac{q_1 q_2}{r^2} \hat{\mathbf{r}} = \frac{1}{4\pi\epsilon_0} \frac{q_1 q_2}{r^2} \hat{\mathbf{r}}$$

where

$$k_e = \frac{1}{4\pi\epsilon_0} = 8.99 \times 10^9 \text{ N} \cdot \text{m}^2 / \text{C}^2$$

is the Coulomb constant.

- The **electric field** at a point in space is defined as the electric force acting on a test charge q_0 divided by q_0 :

$$\vec{\mathbf{E}} = \lim_{q_0 \rightarrow 0} \frac{\vec{\mathbf{F}}_e}{q_0}$$

- The electric field at a distance r from a charge q is

$$\vec{\mathbf{E}} = \frac{1}{4\pi\epsilon_0} \frac{q}{r^2} \hat{\mathbf{r}}$$

- Using the **superposition principle**, the electric field due to a collection of point charges, each having charge q_i and located at a distance r_i away is

$$\vec{\mathbf{E}} = \frac{1}{4\pi\epsilon_0} \sum_i \frac{q_i}{r_i^2} \hat{\mathbf{r}}_i$$

- A particle of mass m and charge q moving in an electric field $\vec{\mathbf{E}}$ has an acceleration

$$\vec{\mathbf{a}} = \frac{q\vec{\mathbf{E}}}{m}$$

- An **electric dipole** consists of two equal but opposite charges. The electric dipole moment vector $\vec{\mathbf{p}}$ points from the negative charge to the positive charge, and has a magnitude

$$p = 2aq$$

- The **torque** acting on an electric dipole placed in a uniform electric field $\vec{\mathbf{E}}$ is

$$\vec{\boldsymbol{\tau}} = \vec{\mathbf{p}} \times \vec{\mathbf{E}}$$

- The **potential energy** of an electric dipole in a uniform external electric field $\vec{\mathbf{E}}$ is

$$U = -\vec{\mathbf{p}} \cdot \vec{\mathbf{E}}$$

- The electric field at a point in space due to a continuous charge element dq is

$$d\vec{\mathbf{E}} = \frac{1}{4\pi\epsilon_0} \frac{dq}{r^2} \hat{\mathbf{r}}$$

- At sufficiently far away from a continuous charge distribution of finite extent, the electric field approaches the “point-charge” limit.

2.12 Problem-Solving Strategies

In this chapter, we have discussed how electric field can be calculated for both the discrete and continuous charge distributions. For the former, we apply the superposition principle:

$$\vec{\mathbf{E}} = \frac{1}{4\pi\epsilon_0} \sum_i \frac{q_i}{r_i^2} \hat{\mathbf{r}}_i$$

For the latter, we must evaluate the vector integral

$$\vec{\mathbf{E}} = \frac{1}{4\pi\epsilon_0} \int \frac{dq}{r^2} \hat{\mathbf{r}}$$

where r is the distance from dq to the field point P and $\hat{\mathbf{r}}$ is the corresponding unit vector. To complete the integration, we shall follow the procedures outlined below:

(1) Start with $d\vec{\mathbf{E}} = \frac{1}{4\pi\epsilon_0} \frac{dq}{r^2} \hat{\mathbf{r}}$

(2) Rewrite the charge element dq as

$$dq = \begin{cases} \lambda d\ell & \text{(length)} \\ \sigma dA & \text{(area)} \\ \rho dV & \text{(volume)} \end{cases}$$

depending on whether the charge is distributed over a length, an area, or a volume.

(3) Substitute dq into the expression for $d\vec{\mathbf{E}}$.

(4) Specify an appropriate coordinate system (Cartesian, cylindrical or spherical) and express the differential element ($d\ell$, dA or dV) and r in terms of the coordinates (see Table 2.1 below for summary.)

	Cartesian (x, y, z)	Cylindrical (ρ, ϕ, z)	Spherical (r, θ, ϕ)
$d\ell$	dx, dy, dz	$d\rho, \rho d\phi, dz$	$dr, r d\theta, r \sin \theta d\phi$
dA	$dx dy, dy dz, dz dx$	$d\rho dz, \rho d\phi dz, \rho d\phi d\rho$	$r dr d\theta, r \sin \theta dr d\phi, r^2 \sin \theta d\theta d\phi$
dV	$dx dy dz$	$\rho d\rho d\phi dz$	$r^2 \sin \theta dr d\theta d\phi$

Table 2.1 Differential elements of length, area and volume in different coordinates

(5) Rewrite $d\vec{E}$ in terms of the integration variable(s), and apply symmetry argument to identify non-vanishing component(s) of the electric field.

(6) Complete the integration to obtain \vec{E} .

In the Table below we illustrate how the above methodologies can be utilized to compute the electric field for an infinite line charge, a ring of charge and a uniformly charged disk.

	Line charge	Ring of charge	Uniformly charged disk
Figure			
(2) Express dq in terms of charge density	$dq = \lambda dx'$	$dq = \lambda d\ell$	$dq = \sigma dA$
(3) Write down dE	$dE = k_e \frac{\lambda dx'}{r'^2}$	$dE = k_e \frac{\lambda d\ell}{r^2}$	$dE = k_e \frac{\sigma dA}{r^2}$
(4) Rewrite r and the differential element in terms of the appropriate coordinates	dx' $\cos \theta = \frac{y}{r'}$ $r' = \sqrt{x'^2 + y^2}$	$d\ell = R d\phi'$ $\cos \theta = \frac{z}{r}$ $r = \sqrt{R^2 + z^2}$	$dA = 2\pi r' dr'$ $\cos \theta = \frac{z}{r}$ $r = \sqrt{r'^2 + z^2}$
(5) Apply symmetry argument to identify non-vanishing component(s) of dE	$dE_y = dE \cos \theta$ $= k_e \frac{\lambda y dx'}{(x'^2 + y^2)^{3/2}}$	$dE_z = dE \cos \theta$ $= k_e \frac{\lambda R z d\phi'}{(R^2 + z^2)^{3/2}}$	$dE_z = dE \cos \theta$ $= k_e \frac{2\pi \sigma z r' dr'}{(r'^2 + z^2)^{3/2}}$
(6) Integrate to get E	$E_y = k_e \lambda y \int_{-\ell/2}^{+\ell/2} \frac{dx}{(x^2 + y^2)^{3/2}}$ $= \frac{2k_e \lambda}{y} \frac{\ell/2}{\sqrt{(\ell/2)^2 + y^2}}$	$E_z = k_e \frac{R\lambda z}{(R^2 + z^2)^{3/2}} \oint d\phi'$ $= k_e \frac{(2\pi R\lambda)z}{(R^2 + z^2)^{3/2}}$ $= k_e \frac{Qz}{(R^2 + z^2)^{3/2}}$	$E_z = 2\pi \sigma k_e z \int_0^R \frac{r' dr'}{(r'^2 + z^2)^{3/2}}$ $= 2\pi \sigma k_e \left(\frac{z}{ z } - \frac{z}{\sqrt{z^2 + R^2}} \right)$

2.13 Solved Problems

2.13.1 Hydrogen Atom

In the classical model of the hydrogen atom, the electron revolves around the proton with a radius of $r = 0.53 \times 10^{-10}$ m. The magnitude of the charge of the electron and proton is $e = 1.6 \times 10^{-19}$ C.

- (a) What is the magnitude of the electric force between the proton and the electron?
- (b) What is the magnitude of the electric field due to the proton at r ?
- (c) What is ratio of the magnitudes of the electrical and gravitational force between electron and proton? Does the result depend on the distance between the proton and the electron?
- (d) In light of your calculation in (b), explain why electrical forces do not influence the motion of planets.

Solutions:

- (a) The magnitude of the force is given by

$$F_e = \frac{1}{4\pi\epsilon_0} \frac{e^2}{r^2}$$

Now we can substitute our numerical values and find that the magnitude of the force between the proton and the electron in the hydrogen atom is

$$F_e = \frac{(9.0 \times 10^9 \text{ N} \cdot \text{m}^2 / \text{C}^2)(1.6 \times 10^{-19} \text{ C})^2}{(5.3 \times 10^{-11} \text{ m})^2} = 8.2 \times 10^{-8} \text{ N}$$

- (b) The magnitude of the electric field due to the proton is given by

$$E = \frac{1}{4\pi\epsilon_0} \frac{q}{r^2} = \frac{(9.0 \times 10^9 \text{ N} \cdot \text{m}^2 / \text{C}^2)(1.6 \times 10^{-19} \text{ C})}{(0.5 \times 10^{-10} \text{ m})^2} = 5.76 \times 10^{11} \text{ N/C}$$

- (c) The mass of the electron is $m_e = 9.1 \times 10^{-31}$ kg and the mass of the proton is $m_p = 1.7 \times 10^{-27}$ kg. Thus, the ratio of the magnitudes of the electric and gravitational force is given by

$$\gamma = \frac{\left(\frac{1}{4\pi\epsilon_0} \frac{e^2}{r^2}\right)}{\left(G \frac{m_p m_e}{r^2}\right)} = \frac{1}{4\pi\epsilon_0} \frac{e^2}{G m_p m_e} = \frac{(9.0 \times 10^9 \text{ N} \cdot \text{m}^2 / \text{C}^2)(1.6 \times 10^{-19} \text{ C})^2}{(6.67 \times 10^{-11} \text{ N} \cdot \text{m}^2 / \text{kg}^2)(1.7 \times 10^{-27} \text{ kg})(9.1 \times 10^{-31} \text{ kg})} = 2.2 \times 10^{39}$$

which is independent of r , the distance between the proton and the electron.

(d) The electric force is 39 orders of magnitude stronger than the gravitational force between the electron and the proton. Then why are the large scale motions of planets determined by the gravitational force and not the electrical force. The answer is that the magnitudes of the charge of the electron and proton are equal. The best experiments show that the difference between these magnitudes is a number on the order of 10^{-24} . Since objects like planets have about the same number of protons as electrons, they are essentially electrically neutral. Therefore the force between planets is entirely determined by gravity.

2.13.2 Millikan Oil-Drop Experiment

An oil drop of radius $r = 1.64 \times 10^{-6} \text{ m}$ and mass density $\rho_{\text{oil}} = 8.51 \times 10^2 \text{ kg/m}^3$ is allowed to fall from rest and then enters into a region of constant external field \vec{E} applied in the downward direction. The oil drop has an unknown electric charge q (due to irradiation by bursts of X-rays). The magnitude of the electric field is adjusted until the gravitational force $\vec{F}_g = m\vec{g} = -mg\hat{j}$ on the oil drop is exactly balanced by the electric force, $\vec{F}_e = q\vec{E}$. Suppose this balancing occurs when the electric field is $\vec{E} = -E_y\hat{j} = -(1.92 \times 10^5 \text{ N/C})\hat{j}$, with $E_y = 1.92 \times 10^5 \text{ N/C}$.

(a) What is the mass of the oil drop?

(b) What is the charge on the oil drop in units of electronic charge $e = 1.6 \times 10^{-19} \text{ C}$?

Solutions:

(a) The mass density ρ_{oil} times the volume of the oil drop will yield the total mass M of the oil drop,

$$M = \rho_{\text{oil}}V = \rho_{\text{oil}}\left(\frac{4}{3}\pi r^3\right)$$

where the oil drop is assumed to be a sphere of radius r with volume $V = 4\pi r^3 / 3$.

Now we can substitute our numerical values into our symbolic expression for the mass,

$$M = \rho_{\text{oil}} \left(\frac{4}{3} \pi r^3 \right) = (8.51 \times 10^2 \text{ kg/m}^3) \left(\frac{4\pi}{3} \right) (1.64 \times 10^{-6} \text{ m})^3 = 1.57 \times 10^{-14} \text{ kg}$$

(b) The oil drop will be in static equilibrium when the gravitational force exactly balances the electrical force: $\vec{F}_g + \vec{F}_e = \vec{0}$. Since the gravitational force points downward, the electric force on the oil must be upward. Using our force laws, we have

$$0 = m\vec{g} + q\vec{E} \Rightarrow mg = -qE_y$$

With the electrical field pointing downward, we conclude that the charge on the oil drop must be negative. Notice that we have chosen the unit vector \hat{j} to point upward. We can solve this equation for the charge on the oil drop:

$$q = -\frac{mg}{E_y} = -\frac{(1.57 \times 10^{-14} \text{ kg})(9.80 \text{ m/s}^2)}{1.92 \times 10^5 \text{ N/C}} = -8.03 \times 10^{-19} \text{ C}$$

Since the electron has charge $e = 1.6 \times 10^{-19} \text{ C}$, the charge of the oil drop in units of e is

$$N = \frac{q}{e} = \frac{8.02 \times 10^{-19} \text{ C}}{1.6 \times 10^{-19} \text{ C}} = 5$$

You may at first be surprised that this number is an integer, but the Millikan oil drop experiment was the first direct experimental evidence that charge is quantized. Thus, from the given data we can assert that there are five electrons on the oil drop!

2.13.3 Charge Moving Perpendicularly to an Electric Field

An electron is injected horizontally into a uniform field produced by two oppositely charged plates, as shown in Figure 2.13.1. The particle has an initial velocity $\vec{v}_0 = v_0 \hat{i}$ perpendicular to \vec{E} .

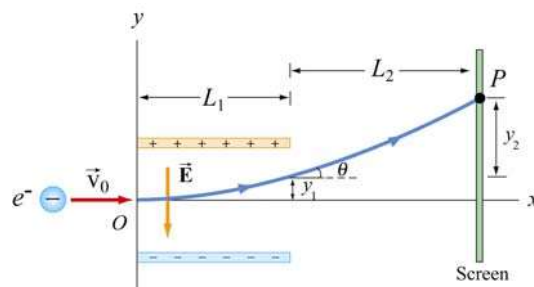

Figure 2.13.1 Charge moving perpendicularly to an electric field

- (a) While between the plates, what is the force on the electron?
- (b) What is the acceleration of the electron when it is between the plates?
- (c) The plates have length L_1 in the x -direction. At what time t_1 will the electron leave the plate?
- (d) Suppose the electron enters the electric field at time $t = 0$. What is the velocity of the electron at time t_1 when it leaves the plates?
- (e) What is the vertical displacement of the electron after time t_1 when it leaves the plates?
- (f) What angle θ_1 does the electron make θ_1 with the horizontal, when the electron leaves the plates at time t_1 ?
- (g) The electron hits the screen located a distance L_2 from the end of the plates at a time t_2 . What is the total vertical displacement of the electron from time $t = 0$ until it hits the screen at t_2 ?

Solutions:

- (a) Since the electron has a negative charge, $q = -e$, the force on the electron is

$$\vec{F}_e = q\vec{E} = -e\vec{E} = (-e)(-E_y)\hat{\mathbf{j}} = eE_y\hat{\mathbf{j}}$$

where the electric field is written as $\vec{E} = -E_y\hat{\mathbf{j}}$, with $E_y > 0$. The force on the electron is upward. Note that the motion of the electron is analogous to the motion of a mass that is thrown horizontally in a constant gravitational field. The mass follows a parabolic trajectory downward. Since the electron is negatively charged, the constant force on the electron is upward and the electron will be deflected upwards on a parabolic path.

- (b) The acceleration of the electron is

$$\vec{a} = \frac{q\vec{E}}{m} = -\frac{qE_y}{m}\hat{\mathbf{j}} = \frac{eE_y}{m}\hat{\mathbf{j}}$$

and its direction is upward.

(c) The time of passage for the electron is given by $t_1 = L_1 / v_0$. The time t_1 is not affected by the acceleration because v_0 , the horizontal component of the velocity which determines the time, is not affected by the field.

(d) The electron has an initial horizontal velocity, $\vec{v}_0 = v_0 \hat{i}$. Since the acceleration of the electron is in the $+y$ -direction, only the y -component of the velocity changes. The velocity at a later time t_1 is given by

$$\vec{v} = v_x \hat{i} + v_y \hat{j} = v_0 \hat{i} + a_y t_1 \hat{j} = v_0 \hat{i} + \left(\frac{eE_y}{m} \right) t_1 \hat{j} = v_0 \hat{i} + \left(\frac{eE_y L_1}{mv_0} \right) \hat{j}$$

(e) From the figure, we see that the electron travels a horizontal distance L_1 in the time $t_1 = L_1 / v_0$ and then emerges from the plates with a vertical displacement

$$y_1 = \frac{1}{2} a_y t_1^2 = \frac{1}{2} \left(\frac{eE_y}{m} \right) \left(\frac{L_1}{v_0} \right)^2$$

(f) When the electron leaves the plates at time t_1 , the electron makes an angle θ_1 with the horizontal given by the ratio of the components of its velocity,

$$\tan \theta = \frac{v_y}{v_x} = \frac{(eE_y / m)(L_1 / v_0)}{v_0} = \frac{eE_y L_1}{mv_0^2}$$

(g) After the electron leaves the plate, there is no longer any force on the electron so it travels in a straight path. The deflection y_2 is

$$y_2 = L_2 \tan \theta_1 = \frac{eE_y L_1 L_2}{mv_0^2}$$

and the total deflection becomes

$$y = y_1 + y_2 = \frac{1}{2} \frac{eE_y L_1^2}{mv_0^2} + \frac{eE_y L_1 L_2}{mv_0^2} = \frac{eE_y L_1}{mv_0^2} \left(\frac{1}{2} L_1 + L_2 \right)$$

2.13.4 Electric Field of a Dipole

Consider the electric dipole moment shown in Figure 2.7.1.

(a) Show that the electric field of the dipole in the limit where $r \gg a$ is

$$E_x = \frac{3p}{4\pi\epsilon_0 r^3} \sin\theta \cos\theta, \quad E_y = \frac{p}{4\pi\epsilon_0 r^3} (3\cos^2\theta - 1)$$

where $\sin\theta = x/r$ and $\cos\theta = y/r$.

(b) Show that the above expression for the electric field can also be written in terms of the polar coordinates as

$$\vec{\mathbf{E}}(r, \theta) = E_r \hat{\mathbf{r}} + E_\theta \hat{\boldsymbol{\theta}}$$

where

$$E_r = \frac{2p \cos\theta}{4\pi\epsilon_0 r^3}, \quad E_\theta = \frac{p \sin\theta}{4\pi\epsilon_0 r^3}$$

Solutions:

(a) Let's compute the electric field strength at a distance $r \gg a$ due to the dipole. The x -component of the electric field strength at the point P with Cartesian coordinates $(x, y, 0)$ is given by

$$E_x = \frac{q}{4\pi\epsilon_0} \left(\frac{\cos\theta_+}{r_+^2} - \frac{\cos\theta_-}{r_-^2} \right) = \frac{q}{4\pi\epsilon_0} \left(\frac{x}{[x^2 + (y-a)^2]^{3/2}} - \frac{x}{[x^2 + (y+a)^2]^{3/2}} \right)$$

where

$$r_\pm^2 = r^2 + a^2 \mp 2ra \cos\theta = x^2 + (y \mp a)^2$$

Similarly, the y -component is given by

$$E_y = \frac{q}{4\pi\epsilon_0} \left(\frac{\sin\theta_+}{r_+^2} - \frac{\sin\theta_-}{r_-^2} \right) = \frac{q}{4\pi\epsilon_0} \left(\frac{y-a}{[x^2 + (y-a)^2]^{3/2}} - \frac{y+a}{[x^2 + (y+a)^2]^{3/2}} \right)$$

We shall make a polynomial expansion for the electric field using the Taylor-series expansion. We will then collect terms that are proportional to $1/r^3$ and ignore terms that are proportional to $1/r^5$, where $r = +(x^2 + y^2)^{1/2}$.

We begin with

$$[x^2 + (y \pm a)^2]^{-3/2} = [x^2 + y^2 + a^2 \pm 2ay]^{-3/2} = r^{-3} \left[1 + \frac{a^2 \pm 2ay}{r^2} \right]^{-3/2}$$

In the limit where $r \gg a$, we use the Taylor-series expansion with $s \equiv (a^2 \pm 2ay)/r^2$:

$$(1 + s)^{-3/2} = 1 - \frac{3}{2}s + \frac{15}{8}s^2 - \dots$$

and the above equations for the components of the electric field becomes

$$E_x = \frac{q}{4\pi\epsilon_0} \frac{6xya}{r^5} + \dots$$

and

$$E_y = \frac{q}{4\pi\epsilon_0} \left(-\frac{2a}{r^3} + \frac{6y^2a}{r^5} \right) + \dots$$

where we have neglected the $O(s^2)$ terms. The electric field can then be written as

$$\vec{\mathbf{E}} = E_x \hat{\mathbf{i}} + E_y \hat{\mathbf{j}} = \frac{q}{4\pi\epsilon_0} \left[-\frac{2a}{r^3} \hat{\mathbf{j}} + \frac{6ya}{r^5} (x \hat{\mathbf{i}} + y \hat{\mathbf{j}}) \right] = \frac{p}{4\pi\epsilon_0 r^3} \left[\frac{3yx}{r^2} \hat{\mathbf{i}} + \left(\frac{3y^2}{r^2} - 1 \right) \hat{\mathbf{j}} \right]$$

where we have made use of the definition of the magnitude of the electric dipole moment $p = 2aq$.

In terms of the polar coordinates, with $\sin \theta = x/r$ and $\cos \theta = y/r$ (as seen from Figure 2.13.4), we obtain the desired results:

$$\boxed{E_x = \frac{3p}{4\pi\epsilon_0 r^3} \sin \theta \cos \theta, \quad E_y = \frac{p}{4\pi\epsilon_0 r^3} (3 \cos^2 \theta - 1)}$$

(b) We begin with the expression obtained in (a) for the electric dipole in Cartesian coordinates:

$$\vec{\mathbf{E}}(r, \theta) = \frac{p}{4\pi\epsilon_0 r^3} \left[3 \sin \theta \cos \theta \hat{\mathbf{i}} + (3 \cos^2 \theta - 1) \hat{\mathbf{j}} \right]$$

With a little algebra, the above expression may be rewritten as

$$\begin{aligned}\vec{\mathbf{E}}(r, \theta) &= \frac{P}{4\pi\epsilon_0 r^3} \left[2 \cos \theta (\sin \theta \hat{\mathbf{i}} + \cos \theta \hat{\mathbf{j}}) + \sin \theta \cos \theta \hat{\mathbf{i}} + (\cos^2 \theta - 1) \hat{\mathbf{j}} \right] \\ &= \frac{P}{4\pi\epsilon_0 r^3} \left[2 \cos \theta (\sin \theta \hat{\mathbf{i}} + \cos \theta \hat{\mathbf{j}}) + \sin \theta (\cos \theta \hat{\mathbf{i}} - \sin \theta \hat{\mathbf{j}}) \right]\end{aligned}$$

where the trigonometric identity $(\cos^2 \theta - 1) = -\sin^2 \theta$ has been used. Since the unit vectors $\hat{\mathbf{r}}$ and $\hat{\boldsymbol{\theta}}$ in polar coordinates can be decomposed as

$$\begin{aligned}\hat{\mathbf{r}} &= \sin \theta \hat{\mathbf{i}} + \cos \theta \hat{\mathbf{j}} \\ \hat{\boldsymbol{\theta}} &= \cos \theta \hat{\mathbf{i}} - \sin \theta \hat{\mathbf{j}},\end{aligned}$$

the electric field in polar coordinates is given by

$$\boxed{\vec{\mathbf{E}}(r, \theta) = \frac{P}{4\pi\epsilon_0 r^3} \left[2 \cos \theta \hat{\mathbf{r}} + \sin \theta \hat{\boldsymbol{\theta}} \right]}$$

and the magnitude of $\vec{\mathbf{E}}$ is

$$E = (E_r^2 + E_\theta^2)^{1/2} = \frac{P}{4\pi\epsilon_0 r^3} (3 \cos^2 \theta + 1)^{1/2}$$

2.13.5 Electric Field of an Arc

A thin rod with a uniform charge per unit length λ is bent into the shape of an arc of a circle of radius R . The arc subtends a total angle $2\theta_0$, symmetric about the x -axis, as shown in Figure 2.13.2. What is the electric field $\vec{\mathbf{E}}$ at the origin O ?

Solution:

Consider a differential element of length $d\ell = R d\theta$, which makes an angle θ with the x -axis, as shown in Figure 2.13.2(b). The amount of charge it carries is $dq = \lambda d\ell = \lambda R d\theta$.

The contribution to the electric field at O is

$$d\vec{\mathbf{E}} = \frac{1}{4\pi\epsilon_0} \frac{dq}{r^2} \hat{\mathbf{r}} = \frac{1}{4\pi\epsilon_0} \frac{dq}{R^2} (-\cos \theta \hat{\mathbf{i}} - \sin \theta \hat{\mathbf{j}}) = \frac{1}{4\pi\epsilon_0} \frac{\lambda d\theta}{R} (-\cos \theta \hat{\mathbf{i}} - \sin \theta \hat{\mathbf{j}})$$

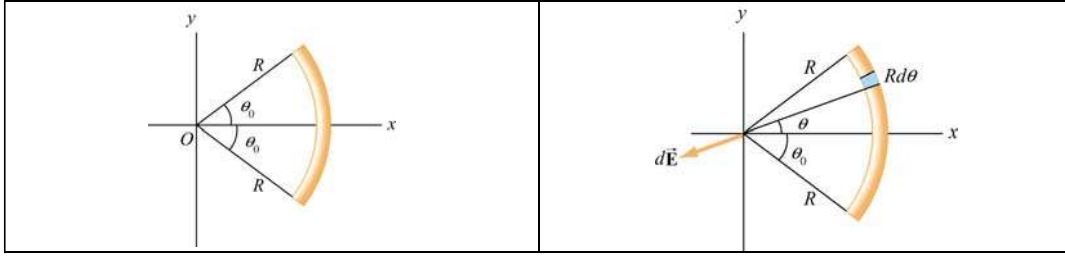

Figure 2.13.2 (a) Geometry of charged source. (b) Charge element dq

Integrating over the angle from $-\theta_0$ to $+\theta_0$, we have

$$\vec{E} = \frac{1}{4\pi\epsilon_0} \frac{\lambda}{R} \int_{-\theta_0}^{\theta_0} d\theta (-\cos\theta \hat{i} - \sin\theta \hat{j}) = \frac{1}{4\pi\epsilon_0} \frac{\lambda}{R} (-\sin\theta \hat{i} + \cos\theta \hat{j}) \Big|_{-\theta_0}^{\theta_0} = -\frac{1}{4\pi\epsilon_0} \frac{2\lambda \sin\theta_0}{R} \hat{i}$$

We see that the electric field only has the x -component, as required by a symmetry argument. If we take the limit $\theta_0 \rightarrow \pi$, the arc becomes a circular ring. Since $\sin\pi = 0$, the equation above implies that the electric field at the center of a non-conducting ring is zero. This is to be expected from symmetry arguments. On the other hand, for very small θ_0 , $\sin\theta_0 \approx \theta_0$ and we recover the point-charge limit:

$$\vec{E} \approx -\frac{1}{4\pi\epsilon_0} \frac{2\lambda\theta_0}{R} \hat{i} = -\frac{1}{4\pi\epsilon_0} \frac{2\lambda\theta_0 R}{R^2} \hat{i} = -\frac{1}{4\pi\epsilon_0} \frac{Q}{R^2} \hat{i}$$

where the total charge on the arc is $Q = \lambda\ell = \lambda(2R\theta_0)$.

2.13.6 Electric Field Off the Axis of a Finite Rod

A non-conducting rod of length ℓ with a uniform charge density λ and a total charge Q is lying along the x -axis, as illustrated in Figure 2.13.3. Compute the electric field at a point P , located at a distance y off the axis of the rod.

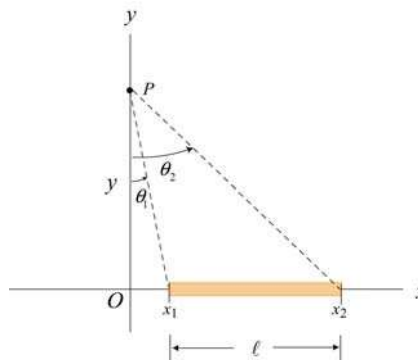

Figure 2.13.3

Solution:

The problem can be solved by following the procedure used in Example 2.3. Consider a length element dx' on the rod, as shown in Figure 2.13.4. The charge carried by the element is $dq = \lambda dx'$.

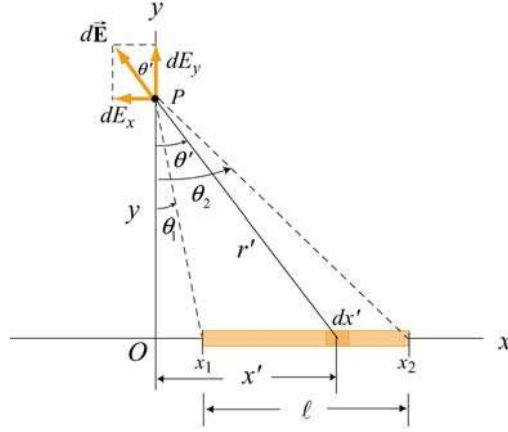

Figure 2.13.4

The electric field at P produced by this element is

$$d\vec{E} = \frac{1}{4\pi\epsilon_0} \frac{dq}{r'^2} \hat{r} = \frac{1}{4\pi\epsilon_0} \frac{\lambda dx'}{x'^2 + y^2} (-\sin \theta' \hat{i} + \cos \theta' \hat{j})$$

where the unit vector \hat{r} has been written in Cartesian coordinates: $\hat{r} = -\sin \theta' \hat{i} + \cos \theta' \hat{j}$. In the absence of symmetry, the field at P has both the x - and y -components. The x -component of the electric field is

$$dE_x = -\frac{1}{4\pi\epsilon_0} \frac{\lambda dx'}{x'^2 + y^2} \sin \theta' = -\frac{1}{4\pi\epsilon_0} \frac{\lambda dx'}{x'^2 + y^2} \frac{x'}{\sqrt{x'^2 + y^2}} = -\frac{1}{4\pi\epsilon_0} \frac{\lambda x' dx'}{(x'^2 + y^2)^{3/2}}$$

Integrating from $x' = x_1$ to $x' = x_2$, we have

$$\begin{aligned} E_x &= -\frac{\lambda}{4\pi\epsilon_0} \int_{x_1}^{x_2} \frac{x' dx'}{(x'^2 + y^2)^{3/2}} = -\frac{\lambda}{4\pi\epsilon_0} \frac{1}{2} \int_{x_1^2 + y^2}^{x_2^2 + y^2} \frac{du}{u^{3/2}} = \frac{\lambda}{4\pi\epsilon_0} u^{-1/2} \Big|_{x_1^2 + y^2}^{x_2^2 + y^2} \\ &= \frac{\lambda}{4\pi\epsilon_0} \left[\frac{1}{\sqrt{x_2^2 + y^2}} - \frac{1}{\sqrt{x_1^2 + y^2}} \right] = \frac{\lambda}{4\pi\epsilon_0 y} \left[\frac{y}{\sqrt{x_2^2 + y^2}} - \frac{y}{\sqrt{x_1^2 + y^2}} \right] \\ &= \frac{\lambda}{4\pi\epsilon_0 y} (\cos \theta_2 - \cos \theta_1) \end{aligned}$$

Similarly, the y -component of the electric field due to the charge element is

$$dE_y = \frac{1}{4\pi\epsilon_0} \frac{\lambda dx'}{x'^2 + y^2} \cos\theta' = \frac{1}{4\pi\epsilon_0} \frac{\lambda dx'}{x'^2 + y^2} \frac{y}{\sqrt{x'^2 + y^2}} = \frac{1}{4\pi\epsilon_0} \frac{\lambda y dx'}{(x'^2 + y^2)^{3/2}}$$

Integrating over the entire length of the rod, we obtain

$$E_y = \frac{\lambda y}{4\pi\epsilon_0} \int_{x_1}^{x_2} \frac{dx'}{(x'^2 + y^2)^{3/2}} = \frac{\lambda y}{4\pi\epsilon_0} \frac{1}{y^2} \int_{\theta_1}^{\theta_2} \cos\theta' d\theta' = \frac{\lambda}{4\pi\epsilon_0 y} (\sin\theta_2 - \sin\theta_1)$$

where we have used the result obtained in Eq. (2.10.8) in completing the integration.

In the infinite length limit where $x_1 \rightarrow -\infty$ and $x_2 \rightarrow +\infty$, with $x_i = y \tan\theta_i$, the corresponding angles are $\theta_1 = -\pi/2$ and $\theta_2 = +\pi/2$. Substituting the values into the expressions above, we have

$$E_x = 0, \quad E_y = \frac{1}{4\pi\epsilon_0} \frac{2\lambda}{y}$$

in complete agreement with the result shown in Eq. (2.10.11).

2.14 Conceptual Questions

1. Compare and contrast Newton's law of gravitation, $F_g = Gm_1m_2/r^2$, and Coulomb's law, $F_e = kq_1q_2/r^2$.
2. Can electric field lines cross each other? Explain.
3. Two opposite charges are placed on a line as shown in the figure below.



The charge on the right is three times the magnitude of the charge on the left. Besides infinity, where else can electric field possibly be zero?

4. A test charge is placed at the point P near a positively-charged insulating rod.

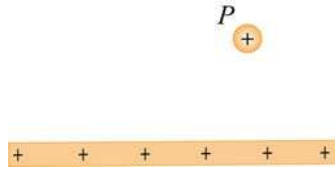

How would the magnitude and direction of the electric field change if the magnitude of the test charge were decreased and its sign changed with everything else remaining the same?

- An electric dipole, consisting of two equal and opposite point charges at the ends of an insulating rod, is free to rotate about a pivot point in the center. The rod is then placed in a non-uniform electric field. Does it experience a force and/or a torque?

2.15 Additional Problems

2.15.1 Three Point Charges

Three point charges are placed at the corners of an equilateral triangle, as shown in Figure 2.15.1.

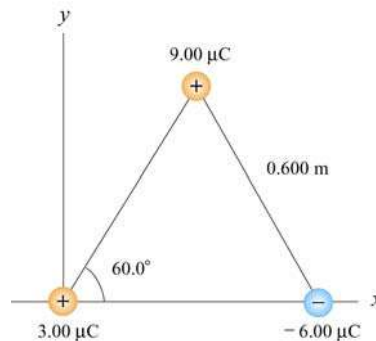
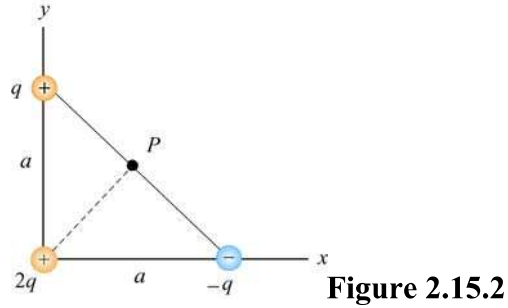

Figure 2.15.1 Three point charges

Calculate the net electric force experienced by (a) the $9.00 \mu\text{C}$ charge, and (b) the $-6.00 \mu\text{C}$ charge.

2.15.2 Three Point Charges

A right isosceles triangle of side a has charges q , $+2q$ and $-q$ arranged on its vertices, as shown in Figure 2.15.2.



What is the electric field at point P , midway between the line connecting the $+q$ and $-q$ charges? Give the magnitude and direction of the electric field.

2.15.3 Four Point Charges

Four point charges are placed at the corners of a square of side a , as shown in Figure 2.15.3.

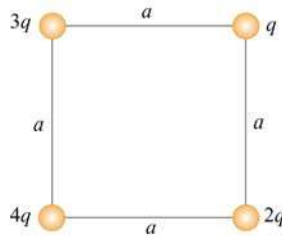
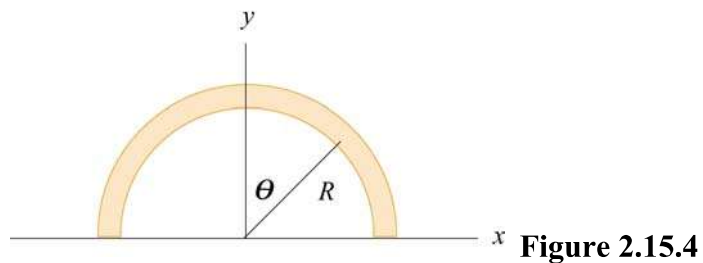

Figure 2.15.3 Four point charges

- (a) What is the electric field at the location of charge q ?
- (b) What is the net force on $2q$?

2.15.4 Semicircular Wire

A positively charged wire is bent into a semicircle of radius R , as shown in Figure 2.15.4.



The total charge on the semicircle is Q . However, the charge per unit length along the semicircle is non-uniform and given by $\lambda = \lambda_0 \cos \theta$.

(a) What is the relationship between λ_0 , R and Q ?

(b) If a charge q is placed at the origin, what is the total force on the charge?

2.15.5 Electric Dipole

An electric dipole lying in the xy -plane with a uniform electric field applied in the $+x$ -direction is displaced by a small angle θ from its equilibrium position, as shown in Figure 2.15.5.

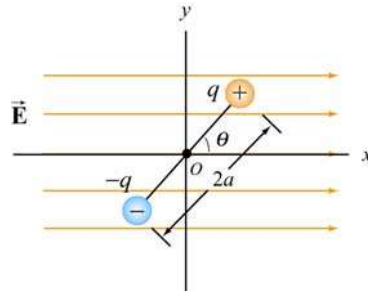

Figure 2.15.5

The charges are separated by a distance $2a$, and the moment of inertia of the dipole is I . If the dipole is released from this position, show that its angular orientation exhibits simple harmonic motion. What is the frequency of oscillation?

2.15.6 Charged Cylindrical Shell and Cylinder

(a) A uniformly charged circular *cylindrical shell* of radius R and height h has a total charge Q . What is the electric field at a point P a distance z from the bottom side of the cylinder as shown in Figure 2.15.6? (*Hint*: Treat the cylinder as a set of ring charges.)

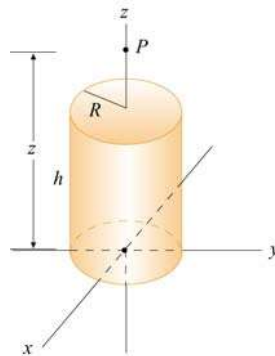
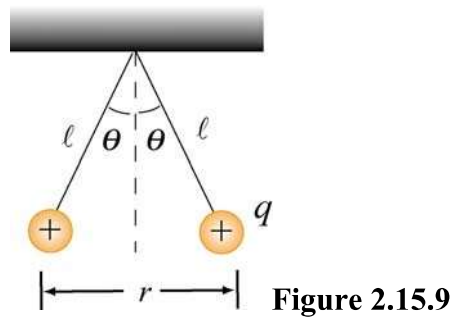

Figure 2.15.6 A uniformly charged cylinder

(b) If the configuration is instead a *solid cylinder* of radius R , height h and has a uniform volume charge density. What is the electric field at P ? (*Hint*: Treat the solid cylinder as a set of disk charges.)

2.15.7 Two Conducting Balls

Two tiny conducting balls of identical mass m and identical charge q hang from non-conducting threads of length l . Each ball forms an angle θ with the vertical axis, as shown in Figure 2.15.9. Assume that θ is so small that $\tan\theta \approx \sin\theta$.



(a) Show that, at equilibrium, the separation between the balls is

$$r = \left(\frac{q^2 l}{2\pi\epsilon_0 mg} \right)^{1/3}$$

(b) If $l = 1.2 \times 10^2$ cm, $m = 1.0 \times 10^1$ g, and $x = 5.0$ cm, what is q ?

2.15.8 Torque on an Electric Dipole

An electric dipole consists of two charges $q_1 = +2e$ and $q_2 = -2e$ ($e = 1.6 \times 10^{-19}$ C), separated by a distance $d = 10^{-9}$ m. The electric charges are placed along the y -axis as shown in Figure 2.15.10.

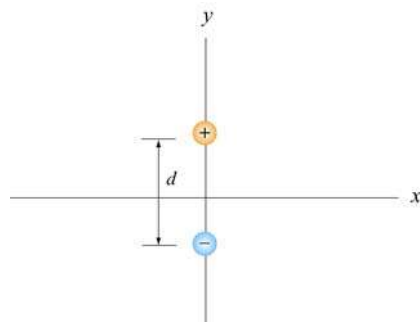

Figure 2.15.10

Suppose a constant external electric field $\vec{\mathbf{E}}_{\text{ext}} = (3\hat{\mathbf{i}} + 3\hat{\mathbf{j}})\text{N/C}$ is applied.

- (a) What is the magnitude and direction of the dipole moment?
- (b) What is the magnitude and direction of the torque on the dipole?
- (c) Do the electric fields of the charges q_1 and q_2 contribute to the torque on the dipole? Briefly explain your answer.

Chapter 3

Electric Potential

3.1 Potential and Potential Energy.....	1
3.2 Electric Potential in a Uniform Field.....	4
3.3 Electric Potential due to Point Charges	5
3.3.1 Potential Energy in a System of Charges.....	7
3.4 Continuous Charge Distribution	8
3.5 Deriving Electric Field from the Electric Potential	9
3.5.1 Gradient and Equipotentials.....	10
Example 3.1: Uniformly Charged Rod	12
Example 3.2: Uniformly Charged Ring	14
Example 3.3: Uniformly Charged Disk	15
Example 3.4: Calculating Electric Field from Electric Potential.....	17
3.6 Summary	17
3.7 Problem-Solving Strategy: Calculating Electric Potential.....	19
3.8 Solved Problems	21
3.8.1 Electric Potential Due to a System of Two Charges.....	21
3.8.2 Electric Dipole Potential	22
3.8.3 Electric Potential of an Annulus	23
3.8.4 Charge Moving Near a Charged Wire	24
3.9 Conceptual Questions	25
3.10 Additional Problems	26
3.10.1 Cube	26
3.10.2 Three Charges	26
3.10.3 Work Done on Charges.....	26
3.10.4 Calculating E from V	27
3.10.5 Electric Potential of a Rod	27
3.10.6 Electric Potential	28
3.10.7 Calculating Electric Field from the Electric Potential	28
3.10.8 Electric Potential and Electric Potential Energy	29
3.10.9. Electric Field, Potential and Energy	29

Electric Potential

3.1 Potential and Potential Energy

In the introductory mechanics course, we have seen that gravitational force from the Earth on a particle of mass m located at a distance r from Earth's center has an inverse-square form:

$$\vec{\mathbf{F}}_g = -G \frac{Mm}{r^2} \hat{\mathbf{r}} \quad (3.1.1)$$

where $G = 6.67 \times 10^{-11} \text{ N} \cdot \text{m}^2/\text{kg}^2$ is the gravitational constant and $\hat{\mathbf{r}}$ is a unit vector pointing radially outward. The Earth is assumed to be a uniform sphere of mass M . The corresponding gravitational field $\vec{\mathbf{g}}$, defined as the gravitational force per unit mass, is given by

$$\vec{\mathbf{g}} = \frac{\vec{\mathbf{F}}_g}{m} = -\frac{GM}{r^2} \hat{\mathbf{r}} \quad (3.1.2)$$

Notice that $\vec{\mathbf{g}}$ only depends on M , the mass which creates the field, and r , the distance from M .

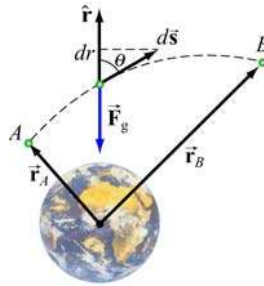

Figure 3.1.1

Consider moving a particle of mass m under the influence of gravity (Figure 3.1.1). The work done by gravity in moving m from A to B is

$$W_g = \int \vec{\mathbf{F}}_g \cdot d\vec{\mathbf{s}} = \int_{r_A}^{r_B} \left(-\frac{GMm}{r^2} \right) dr = \left[\frac{GMm}{r} \right]_{r_A}^{r_B} = GMm \left(\frac{1}{r_B} - \frac{1}{r_A} \right) \quad (3.1.3)$$

The result shows that W_g is independent of the path taken; it depends only on the endpoints A and B . It is important to draw distinction between W_g , the work done by the

field and W_{ext} , the work done by an external agent such as you. They simply differ by a negative sign: $W_g = -W_{\text{ext}}$.

Near Earth's surface, the gravitational field \vec{g} is approximately constant, with a magnitude $g = GM / r_E^2 \approx 9.8 \text{ m/s}^2$, where r_E is the radius of Earth. The work done by gravity in moving an object from height y_A to y_B (Figure 3.1.2) is

$$W_g = \int \vec{F}_g \cdot d\vec{s} = \int_A^B mg \cos \theta ds = -\int_A^B mg \cos \phi ds = -\int_{y_A}^{y_B} mg dy = -mg(y_B - y_A) \quad (3.1.4)$$

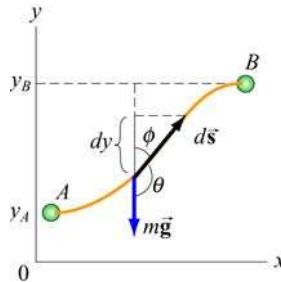

Figure 3.1.2 Moving a mass m from A to B .

The result again is independent of the path, and is only a function of the change in vertical height $y_B - y_A$.

In the examples above, if the path forms a closed loop, so that the object moves around and then returns to where it starts off, the net work done by the gravitational field would be zero, and we say that the gravitational force is conservative. More generally, a force \vec{F} is said to be *conservative* if its line integral around a closed loop vanishes:

$$\oint \vec{F} \cdot d\vec{s} = 0 \quad (3.1.5)$$

When dealing with a conservative force, it is often convenient to introduce the concept of potential energy U . The change in potential energy associated with a conservative force \vec{F} acting on an object as it moves from A to B is defined as:

$$\Delta U = U_B - U_A = -\int_A^B \vec{F} \cdot d\vec{s} = -W \quad (3.1.6)$$

where W is the work done by the force on the object. In the case of gravity, $W = W_g$ and from Eq. (3.1.3), the potential energy can be written as

$$U_g = -\frac{GMm}{r} + U_0 \quad (3.1.7)$$

where U_0 is an arbitrary constant which depends on a reference point. It is often convenient to choose a reference point where U_0 is equal to zero. In the gravitational case, we choose infinity to be the reference point, with $U_0(r = \infty) = 0$. Since U_g depends on the reference point chosen, it is only the potential energy difference ΔU_g that has physical importance. Near Earth's surface where the gravitational field \vec{g} is approximately constant, as an object moves from the ground to a height h , the change in potential energy is $\Delta U_g = +mgh$, and the work done by gravity is $W_g = -mgh$.

A concept which is closely related to potential energy is "potential." From ΔU , the gravitational potential can be obtained as

$$\Delta V_g = \frac{\Delta U_g}{m} = -\int_A^B (\vec{F}_g / m) \cdot d\vec{s} = -\int_A^B \vec{g} \cdot d\vec{s} \quad (3.1.8)$$

Physically ΔV_g represents the negative of the work done per unit mass by gravity to move a particle from A to B .

Our treatment of electrostatics is remarkably similar to gravitation. The electrostatic force \vec{F}_e given by Coulomb's law also has an inverse-square form. In addition, it is also conservative. In the presence of an electric field \vec{E} , in analogy to the gravitational field \vec{g} , we define the electric potential difference between two points A and B as

$$\Delta V = -\int_A^B (\vec{F}_e / q_0) \cdot d\vec{s} = -\int_A^B \vec{E} \cdot d\vec{s} \quad (3.1.9)$$

where q_0 is a test charge. The potential difference ΔV represents the amount of work done per unit charge to move a test charge q_0 from point A to B , without changing its kinetic energy. Again, electric potential should not be confused with electric potential energy. The two quantities are related by

$$\Delta U = q_0 \Delta V \quad (3.1.10)$$

The SI unit of electric potential is volt (V):

$$1 \text{ volt} = 1 \text{ joule/coulomb} \quad (1 \text{ V} = 1 \text{ J/C}) \quad (3.1.11)$$

When dealing with systems at the atomic or molecular scale, a joule (J) often turns out to be too large as an energy unit. A more useful scale is electron volt (eV), which is defined as the energy an electron acquires (or loses) when moving through a potential difference of one volt:

$$1\text{eV} = (1.6 \times 10^{-19}\text{C})(1\text{V}) = 1.6 \times 10^{-19}\text{J} \quad (3.1.12)$$

3.2 Electric Potential in a Uniform Field

Consider a charge $+q$ moving in the direction of a uniform electric field $\vec{E} = E_0(-\hat{j})$, as shown in Figure 3.2.1(a).

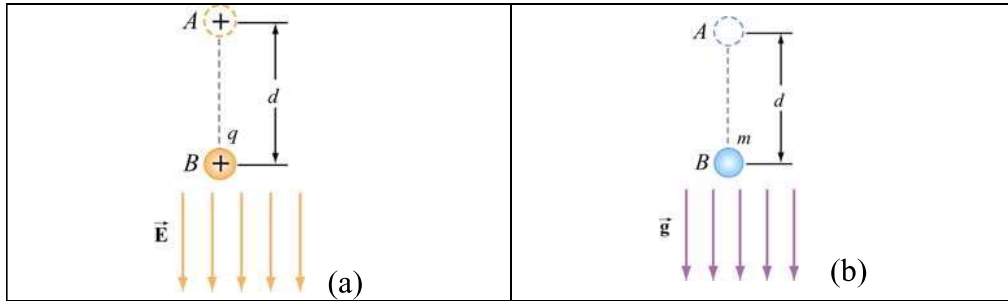

Figure 3.2.1 (a) A charge q which moves in the direction of a constant electric field \vec{E} . (b) A mass m that moves in the direction of a constant gravitational field \vec{g} .

Since the path taken is parallel to \vec{E} , the potential difference between points A and B is given by

$$\Delta V = V_B - V_A = -\int_A^B \vec{E} \cdot d\vec{s} = -E_0 \int_A^B ds = -E_0 d < 0 \quad (3.2.1)$$

implying that point B is at a lower potential compared to A . In fact, electric field lines always point from higher potential to lower. The change in potential energy is $\Delta U = U_B - U_A = -qE_0 d$. Since $q > 0$, we have $\Delta U < 0$, which implies that the potential energy of a positive charge decreases as it moves along the direction of the electric field. The corresponding gravitational analogy, depicted in Figure 3.2.1(b), is that a mass m loses potential energy ($\Delta U = -mgd$) as it moves in the direction of the gravitational field \vec{g} .

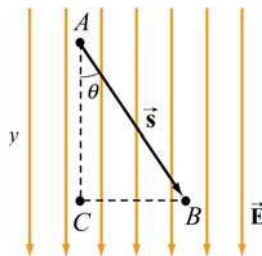

Figure 3.2.2 Potential difference due to a uniform electric field

What happens if the path from A to B is not parallel to \vec{E} , but instead at an angle θ , as shown in Figure 3.2.2? In that case, the potential difference becomes

$$\Delta V = V_B - V_A = -\int_A^B \vec{E} \cdot d\vec{s} = -\vec{E} \cdot \vec{s} = -E_0 s \cos \theta = -E_0 y \quad (3.2.2)$$

Note that y increase downward in Figure 3.2.2. Here we see once more that moving along the direction of the electric field \vec{E} leads to a lower electric potential. What would the change in potential be if the path were $A \rightarrow C \rightarrow B$? In this case, the potential difference consists of two contributions, one for each segment of the path:

$$\Delta V = \Delta V_{CA} + \Delta V_{BC} \quad (3.2.3)$$

When moving from A to C , the change in potential is $\Delta V_{CA} = -E_0 y$. On the other hand, when going from C to B , $\Delta V_{BC} = 0$ since the path is perpendicular to the direction of \vec{E} . Thus, the same result is obtained irrespective of the path taken, consistent with the fact that \vec{E} is conservative.

Notice that for the path $A \rightarrow C \rightarrow B$, work is done by the field only along the segment AC which is parallel to the field lines. Points B and C are at the same electric potential, i.e., $V_B = V_C$. Since $\Delta U = q\Delta V$, this means that no work is required in moving a charge from B to C . In fact, all points along the straight line connecting B and C are on the same “equipotential line.” A more complete discussion of equipotential will be given in Section 3.5.

3.3 Electric Potential due to Point Charges

Next, let’s compute the potential difference between two points A and B due to a charge $+Q$. The electric field produced by Q is $\vec{E} = (Q/4\pi\epsilon_0 r^2)\hat{r}$, where \hat{r} is a unit vector pointing toward the field point.

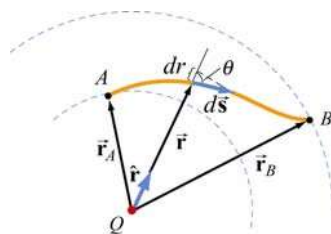

Figure 3.3.1 Potential difference between two points due to a point charge Q .

From Figure 3.3.1, we see that $\hat{r} \cdot d\vec{s} = ds \cos \theta = dr$, which gives

$$\Delta V = V_B - V_A = -\int_A^B \frac{Q}{4\pi\epsilon_0 r^2} \hat{r} \cdot d\vec{s} = -\int_A^B \frac{Q}{4\pi\epsilon_0 r^2} dr = \frac{Q}{4\pi\epsilon_0} \left(\frac{1}{r_B} - \frac{1}{r_A} \right) \quad (3.3.1)$$

Once again, the potential difference ΔV depends only on the endpoints, independent of the choice of path taken.

As in the case of gravity, only the difference in electrical potential is physically meaningful, and one may choose a reference point and set the potential there to be zero. In practice, it is often convenient to choose the reference point to be at infinity, so that the electric potential at a point P becomes

$$V_P = -\int_{\infty}^P \vec{\mathbf{E}} \cdot d\vec{\mathbf{s}} \quad (3.3.2)$$

With this reference, the electric potential at a distance r away from a point charge Q becomes

$$V(r) = \frac{1}{4\pi\epsilon_0} \frac{Q}{r} \quad (3.3.3)$$

When more than one point charge is present, by applying the superposition principle, the total electric potential is simply the sum of potentials due to individual charges:

$$V(r) = \frac{1}{4\pi\epsilon_0} \sum_i \frac{q_i}{r_i} = k_e \sum_i \frac{q_i}{r_i} \quad (3.3.4)$$

A summary of comparison between gravitation and electrostatics is tabulated below:

Gravitation	Electrostatics
Mass m	Charge q
Gravitational force $\vec{\mathbf{F}}_g = -G \frac{Mm}{r^2} \hat{\mathbf{r}}$	Coulomb force $\vec{\mathbf{F}}_e = k_e \frac{Qq}{r^2} \hat{\mathbf{r}}$
Gravitational field $\vec{\mathbf{g}} = \vec{\mathbf{F}}_g / m$	Electric field $\vec{\mathbf{E}} = \vec{\mathbf{F}}_e / q$
Potential energy change $\Delta U = -\int_A^B \vec{\mathbf{F}}_g \cdot d\vec{\mathbf{s}}$	Potential energy change $\Delta U = -\int_A^B \vec{\mathbf{F}}_e \cdot d\vec{\mathbf{s}}$
Gravitational potential $V_g = -\int_A^B \vec{\mathbf{g}} \cdot d\vec{\mathbf{s}}$	Electric Potential $V = -\int_A^B \vec{\mathbf{E}} \cdot d\vec{\mathbf{s}}$
For a source M : $V_g = -\frac{GM}{r}$	For a source Q : $V = k_e \frac{Q}{r}$
$ \Delta U_g = mgd$ (constant $\vec{\mathbf{g}}$)	$ \Delta U = qEd$ (constant $\vec{\mathbf{E}}$)

3.3.1 Potential Energy in a System of Charges

If a system of charges is assembled by an external agent, then $\Delta U = -W = +W_{\text{ext}}$. That is, the change in potential energy of the system is the work that must be put in by an external agent to assemble the configuration. A simple example is lifting a mass m through a height h . The work done by an external agent you, is $+mgh$ (The gravitational field does work $-mgh$). The charges are brought in from infinity without acceleration i.e. they are at rest at the end of the process. Let's start with just two charges q_1 and q_2 . Let the potential due to q_1 at a point P be V_1 (Figure 3.3.2).

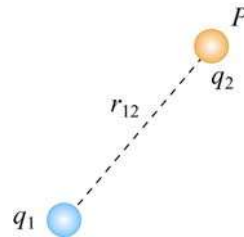

Figure 3.3.2 Two point charges separated by a distance r_{12} .

The work W_2 done by an agent in bringing the second charge q_2 from infinity to P is then $W_2 = q_2 V_1$. (No work is required to set up the first charge and $W_1 = 0$). Since $V_1 = q_1 / 4\pi\epsilon_0 r_{12}$, where r_{12} is the distance measured from q_1 to P , we have

$$U_{12} = W_2 = \frac{1}{4\pi\epsilon_0} \frac{q_1 q_2}{r_{12}} \quad (3.3.5)$$

If q_1 and q_2 have the same sign, positive work must be done to overcome the electrostatic repulsion and the potential energy of the system is positive, $U_{12} > 0$. On the other hand, if the signs are opposite, then $U_{12} < 0$ due to the attractive force between the charges.

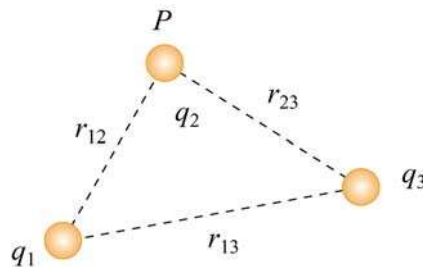

Figure 3.3.3 A system of three point charges.

To add a third charge q_3 to the system (Figure 3.3.3), the work required is

$$W_3 = q_3 (V_1 + V_2) = \frac{q_3}{4\pi\epsilon_0} \left(\frac{q_1}{r_{13}} + \frac{q_2}{r_{23}} \right) \quad (3.3.6)$$

The potential energy of this configuration is then

$$U = W_2 + W_3 = \frac{1}{4\pi\epsilon_0} \left(\frac{q_1 q_2}{r_{12}} + \frac{q_1 q_3}{r_{13}} + \frac{q_2 q_3}{r_{23}} \right) = U_{12} + U_{13} + U_{23} \quad (3.3.7)$$

The equation shows that the total potential energy is simply the sum of the contributions from distinct pairs. Generalizing to a system of N charges, we have

$$U = \frac{1}{4\pi\epsilon_0} \sum_{i=1}^N \sum_{\substack{j=1 \\ j>i}}^N \frac{q_i q_j}{r_{ij}} \quad (3.3.8)$$

where the constraint $j > i$ is placed to avoid double counting each pair. Alternatively, one may count each pair twice and divide the result by 2. This leads to

$$U = \frac{1}{8\pi\epsilon_0} \sum_{i=1}^N \sum_{\substack{j=1 \\ j \neq i}}^N \frac{q_i q_j}{r_{ij}} = \frac{1}{2} \sum_{i=1}^N q_i \left(\frac{1}{4\pi\epsilon_0} \sum_{\substack{j=1 \\ j \neq i}}^N \frac{q_j}{r_{ij}} \right) = \frac{1}{2} \sum_{i=1}^N q_i V(r_i) \quad (3.3.9)$$

where $V(r_i)$, the quantity in the parenthesis, is the potential at \vec{r}_i (location of q_i) due to all the other charges.

3.4 Continuous Charge Distribution

If the charge distribution is continuous, the potential at a point P can be found by summing over the contributions from individual differential elements of charge dq .



Figure 3.4.1 Continuous charge distribution

Consider the charge distribution shown in Figure 3.4.1. Taking infinity as our reference point with zero potential, the electric potential at P due to dq is

$$dV = \frac{1}{4\pi\epsilon_0} \frac{dq}{r} \quad (3.4.1)$$

Summing over contributions from all differential elements, we have

$$V = \frac{1}{4\pi\epsilon_0} \int \frac{dq}{r} \quad (3.4.2)$$

3.5 Deriving Electric Field from the Electric Potential

In Eq. (3.1.9) we established the relation between $\vec{\mathbf{E}}$ and V . If we consider two points which are separated by a small distance $d\vec{\mathbf{s}}$, the following differential form is obtained:

$$dV = -\vec{\mathbf{E}} \cdot d\vec{\mathbf{s}} \quad (3.5.1)$$

In Cartesian coordinates, $\vec{\mathbf{E}} = E_x\hat{\mathbf{i}} + E_y\hat{\mathbf{j}} + E_z\hat{\mathbf{k}}$ and $d\vec{\mathbf{s}} = dx\hat{\mathbf{i}} + dy\hat{\mathbf{j}} + dz\hat{\mathbf{k}}$, we have

$$dV = (E_x\hat{\mathbf{i}} + E_y\hat{\mathbf{j}} + E_z\hat{\mathbf{k}}) \cdot (dx\hat{\mathbf{i}} + dy\hat{\mathbf{j}} + dz\hat{\mathbf{k}}) = E_x dx + E_y dy + E_z dz \quad (3.5.2)$$

which implies

$$E_x = -\frac{\partial V}{\partial x}, \quad E_y = -\frac{\partial V}{\partial y}, \quad E_z = -\frac{\partial V}{\partial z} \quad (3.5.3)$$

By introducing a differential quantity called the “del (gradient) operator”

$$\nabla \equiv \frac{\partial}{\partial x}\hat{\mathbf{i}} + \frac{\partial}{\partial y}\hat{\mathbf{j}} + \frac{\partial}{\partial z}\hat{\mathbf{k}} \quad (3.5.4)$$

the electric field can be written as

$$\begin{aligned} \vec{\mathbf{E}} = E_x\hat{\mathbf{i}} + E_y\hat{\mathbf{j}} + E_z\hat{\mathbf{k}} &= -\left(\frac{\partial V}{\partial x}\hat{\mathbf{i}} + \frac{\partial V}{\partial y}\hat{\mathbf{j}} + \frac{\partial V}{\partial z}\hat{\mathbf{k}}\right) = -\left(\frac{\partial}{\partial x}\hat{\mathbf{i}} + \frac{\partial}{\partial y}\hat{\mathbf{j}} + \frac{\partial}{\partial z}\hat{\mathbf{k}}\right)V = -\nabla V \\ \vec{\mathbf{E}} &= -\nabla V \end{aligned} \quad (3.5.5)$$

Notice that ∇ operates on a scalar quantity (electric potential) and results in a vector quantity (electric field). Mathematically, we can think of $\vec{\mathbf{E}}$ as the negative of the *gradient* of the electric potential V . Physically, the negative sign implies that if

V increases as a positive charge moves along some direction, say x , with $\partial V / \partial x > 0$, then there is a non-vanishing component of $\vec{\mathbf{E}}$ in the opposite direction ($-E_x \neq 0$). In the case of gravity, if the gravitational potential increases when a mass is lifted a distance h , the gravitational force must be downward.

If the charge distribution possesses spherical symmetry, then the resulting electric field is a function of the radial distance r , i.e., $\vec{\mathbf{E}} = E_r \hat{\mathbf{r}}$. In this case, $dV = -E_r dr$. If $V(r)$ is known, then $\vec{\mathbf{E}}$ may be obtained as

$$\boxed{\vec{\mathbf{E}} = E_r \hat{\mathbf{r}} = -\left(\frac{dV}{dr}\right) \hat{\mathbf{r}}} \quad (3.5.6)$$

For example, the electric potential due to a point charge q is $V(r) = q / 4\pi\epsilon_0 r$. Using the above formula, the electric field is simply $\vec{\mathbf{E}} = (q / 4\pi\epsilon_0 r^2) \hat{\mathbf{r}}$.

3.5.1 Gradient and Equipotentials

Suppose a system in two dimensions has an electric potential $V(x, y)$. The curves characterized by constant $V(x, y)$ are called equipotential curves. Examples of equipotential curves are depicted in Figure 3.5.1 below.

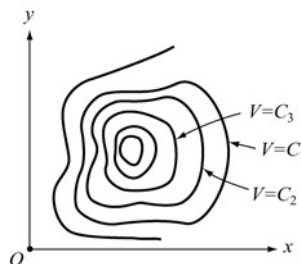

Figure 3.5.1 Equipotential curves

In three dimensions we have equipotential surfaces and they are described by $V(x, y, z) = \text{constant}$. Since $\vec{\mathbf{E}} = -\nabla V$, we can show that the direction of $\vec{\mathbf{E}}$ is always perpendicular to the equipotential through the point. Below we give a proof in two dimensions. Generalization to three dimensions is straightforward.

Proof:

Referring to Figure 3.5.2, let the potential at a point $P(x, y)$ be $V(x, y)$. How much is V changed at a neighboring point $P(x + dx, y + dy)$? Let the difference be written as

$$\begin{aligned}
 dV &= V(x+dx, y+dy) - V(x, y) \\
 &= \left[V(x, y) + \frac{\partial V}{\partial x} dx + \frac{\partial V}{\partial y} dy + \dots \right] - V(x, y) \approx \frac{\partial V}{\partial x} dx + \frac{\partial V}{\partial y} dy \quad (3.5.7)
 \end{aligned}$$

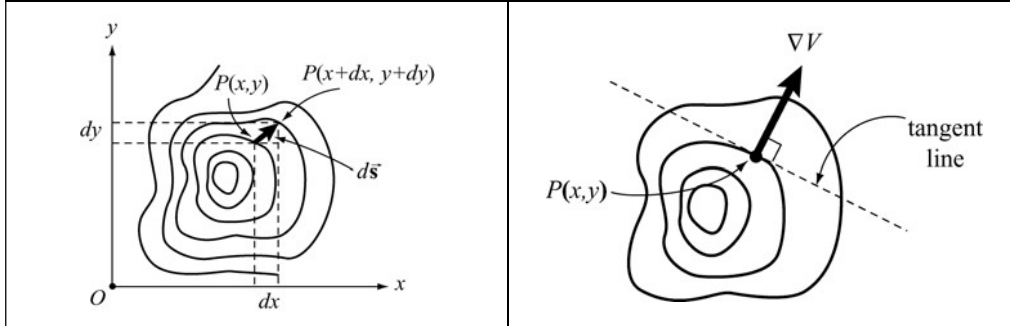

Figure 3.5.2 Change in V when moving from one equipotential curve to another

With the displacement vector given by $d\vec{s} = dx\hat{i} + dy\hat{j}$, we can rewrite dV as

$$dV = \left(\frac{\partial V}{\partial x} \hat{i} + \frac{\partial V}{\partial y} \hat{j} \right) \cdot (dx\hat{i} + dy\hat{j}) = (\nabla V) \cdot d\vec{s} = -\vec{E} \cdot d\vec{s} \quad (3.5.8)$$

If the displacement $d\vec{s}$ is along the tangent to the equipotential curve through $P(x, y)$, then $dV = 0$ because V is constant everywhere on the curve. This implies that $\vec{E} \perp d\vec{s}$ along the equipotential curve. That is, \vec{E} is perpendicular to the equipotential. In Figure 3.5.3 we illustrate some examples of equipotential curves. In three dimensions they become equipotential surfaces. From Eq. (3.5.8), we also see that the change in potential dV attains a maximum when the gradient ∇V is parallel to $d\vec{s}$:

$$\max \left(\frac{dV}{ds} \right) = |\nabla V| \quad (3.5.9)$$

Physically, this means that ∇V always points in the direction of maximum rate of change of V with respect to the displacement s .

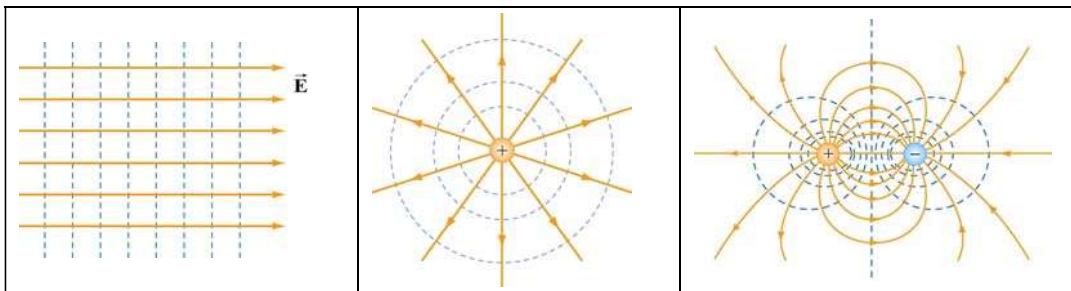

Figure 3.5.3 Equipotential curves and electric field lines for (a) a constant \vec{E} field, (b) a point charge, and (c) an electric dipole.

The properties of equipotential surfaces can be summarized as follows:

- (i) The electric field lines are perpendicular to the equipotentials and point from higher to lower potentials.
- (ii) By symmetry, the equipotential surfaces produced by a point charge form a family of concentric spheres, and for constant electric field, a family of planes perpendicular to the field lines.
- (iii) The tangential component of the electric field along the equipotential surface is zero, otherwise non-vanishing work would be done to move a charge from one point on the surface to the other.
- (iv) No work is required to move a particle along an equipotential surface.

A useful analogy for equipotential curves is a topographic map (Figure 3.5.4). Each contour line on the map represents a fixed elevation above sea level. Mathematically it is expressed as $z = f(x, y) = \text{constant}$. Since the gravitational potential near the surface of Earth is $V_g = gz$, these curves correspond to gravitational equipotentials.

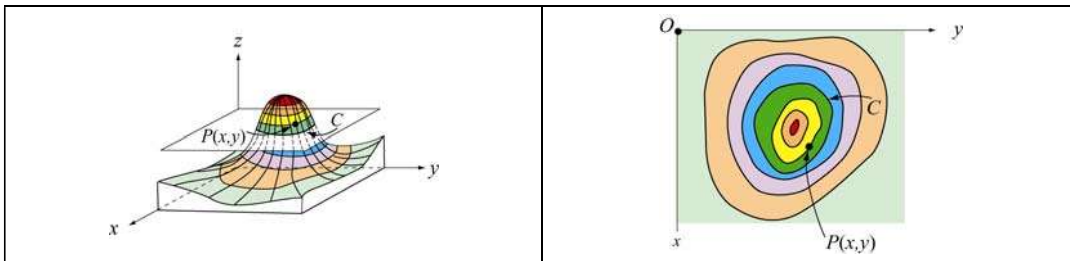

Figure 3.5.4 A topographic map

Example 3.1: Uniformly Charged Rod

Consider a non-conducting rod of length ℓ having a uniform charge density λ . Find the electric potential at P , a perpendicular distance y above the midpoint of the rod.

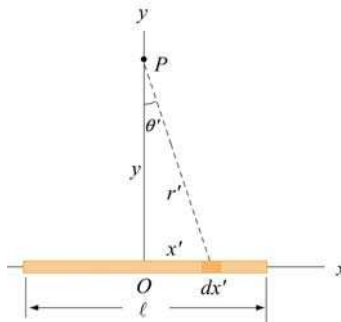

Figure 3.5.5 A non-conducting rod of length ℓ and uniform charge density λ .

Solution:

Consider a differential element of length dx' which carries a charge $dq = \lambda dx'$, as shown in Figure 3.5.5. The source element is located at $(x', 0)$, while the field point P is located on the y -axis at $(0, y)$. The distance from dx' to P is $r = (x'^2 + y^2)^{1/2}$. Its contribution to the potential is given by

$$dV = \frac{1}{4\pi\epsilon_0} \frac{dq}{r} = \frac{1}{4\pi\epsilon_0} \frac{\lambda dx'}{(x'^2 + y^2)^{1/2}}$$

Taking V to be zero at infinity, the total potential due to the entire rod is

$$\begin{aligned} V &= \frac{\lambda}{4\pi\epsilon_0} \int_{-\ell/2}^{\ell/2} \frac{dx'}{\sqrt{x'^2 + y^2}} = \frac{\lambda}{4\pi\epsilon_0} \ln \left[x' + \sqrt{x'^2 + y^2} \right] \Bigg|_{-\ell/2}^{\ell/2} \\ &= \frac{\lambda}{4\pi\epsilon_0} \ln \left[\frac{(\ell/2) + \sqrt{(\ell/2)^2 + y^2}}{-\ell/2 + \sqrt{(\ell/2)^2 + y^2}} \right] \end{aligned} \quad (3.5.10)$$

where we have used the integration formula

$$\int \frac{dx'}{\sqrt{x'^2 + y^2}} = \ln \left(x' + \sqrt{x'^2 + y^2} \right)$$

A plot of $V(y)/V_0$, where $V_0 = \lambda/4\pi\epsilon_0$, as a function of y/ℓ is shown in Figure 3.5.6

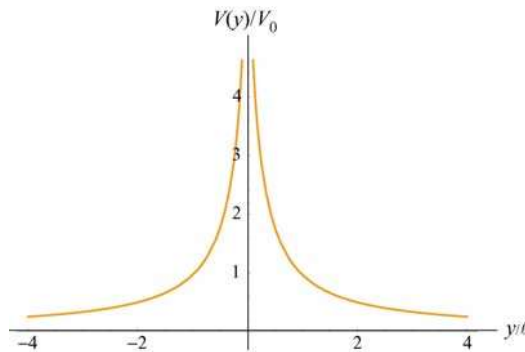

Figure 3.5.6 Electric potential along the axis that passes through the midpoint of a non-conducting rod.

In the limit $\ell \gg y$, the potential becomes

$$\begin{aligned}
V &= \frac{\lambda}{4\pi\epsilon_0} \ln \left[\frac{(\ell/2) + \ell/2\sqrt{1+(2y/\ell)^2}}{-(\ell/2) + \ell/2\sqrt{1+(2y/\ell)^2}} \right] = \frac{\lambda}{4\pi\epsilon_0} \ln \left[\frac{1 + \sqrt{1+(2y/\ell)^2}}{-1 + \sqrt{1+(2y/\ell)^2}} \right] \\
&\approx \frac{\lambda}{4\pi\epsilon_0} \ln \left(\frac{2}{2y^2/\ell^2} \right) = \frac{\lambda}{4\pi\epsilon_0} \ln \left(\frac{\ell^2}{y^2} \right) \\
&= \frac{\lambda}{2\pi\epsilon_0} \ln \left(\frac{\ell}{y} \right)
\end{aligned} \tag{3.5.11}$$

The corresponding electric field can be obtained as

$$E_y = -\frac{\partial V}{\partial y} = \frac{\lambda}{2\pi\epsilon_0 y} \frac{\ell/2}{\sqrt{(\ell/2)^2 + y^2}}$$

in complete agreement with the result obtained in Eq. (2.10.9).

Example 3.2: Uniformly Charged Ring

Consider a uniformly charged ring of radius R and charge density λ (Figure 3.5.7). What is the electric potential at a distance z from the central axis?

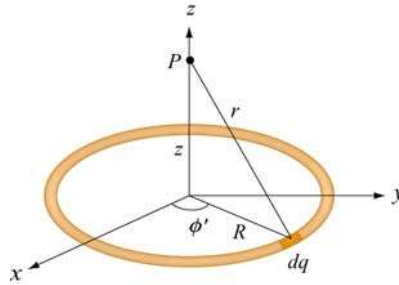

Figure 3.5.7 A non-conducting ring of radius R with uniform charge density λ .

Solution:

Consider a small differential element $d\ell = R d\phi'$ on the ring. The element carries a charge $dq = \lambda d\ell = \lambda R d\phi'$, and its contribution to the electric potential at P is

$$dV = \frac{1}{4\pi\epsilon_0} \frac{dq}{r} = \frac{1}{4\pi\epsilon_0} \frac{\lambda R d\phi'}{\sqrt{R^2 + z^2}}$$

The electric potential at P due to the entire ring is

$$V = \int dV = \frac{1}{4\pi\epsilon_0} \frac{\lambda R}{\sqrt{R^2 + z^2}} \oint d\phi' = \frac{1}{4\pi\epsilon_0} \frac{2\pi\lambda R}{\sqrt{R^2 + z^2}} = \frac{1}{4\pi\epsilon_0} \frac{Q}{\sqrt{R^2 + z^2}} \quad (3.5.12)$$

where we have substituted $Q = 2\pi R\lambda$ for the total charge on the ring. In the limit $z \gg R$, the potential approaches its “point-charge” limit:

$$V \approx \frac{1}{4\pi\epsilon_0} \frac{Q}{z}$$

From Eq. (3.5.12), the z -component of the electric field may be obtained as

$$E_z = -\frac{\partial V}{\partial z} = -\frac{\partial}{\partial z} \left(\frac{1}{4\pi\epsilon_0} \frac{Q}{\sqrt{R^2 + z^2}} \right) = \frac{1}{4\pi\epsilon_0} \frac{Qz}{(R^2 + z^2)^{3/2}} \quad (3.5.13)$$

in agreement with Eq. (2.10.14).

Example 3.3: Uniformly Charged Disk

Consider a uniformly charged disk of radius R and charge density σ lying in the xy -plane. What is the electric potential at a distance z from the central axis?

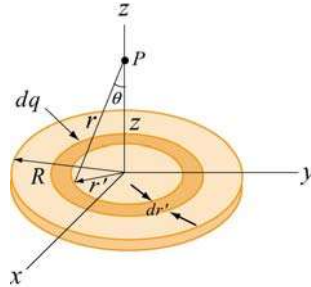

Figure 3.4.3 A non-conducting disk of radius R and uniform charge density σ .

Solution:

Consider a circular ring of radius r' and width dr' . The charge on the ring is $dq' = \sigma dA' = \sigma(2\pi r' dr')$. The field point P is located along the z -axis a distance z from the plane of the disk. From the figure, we also see that the distance from a point on the ring to P is $r = (r'^2 + z^2)^{1/2}$. Therefore, the contribution to the electric potential at P is

$$dV = \frac{1}{4\pi\epsilon_0} \frac{dq}{r} = \frac{1}{4\pi\epsilon_0} \frac{\sigma(2\pi r' dr')}{\sqrt{r'^2 + z^2}}$$

By summing over all the rings that make up the disk, we have

$$V = \frac{\sigma}{4\pi\epsilon_0} \int_0^R \frac{2\pi r' dr'}{\sqrt{r'^2 + z^2}} = \frac{\sigma}{2\epsilon_0} \left[\sqrt{r'^2 + z^2} \right]_0^R = \frac{\sigma}{2\epsilon_0} \left[\sqrt{R^2 + z^2} - |z| \right] \quad (3.5.14)$$

In the limit $|z| \gg R$,

$$\sqrt{R^2 + z^2} = |z| \left(1 + \frac{R^2}{z^2} \right)^{1/2} = |z| \left(1 + \frac{R^2}{2z^2} + \dots \right),$$

and the potential simplifies to the point-charge limit:

$$V \approx \frac{\sigma}{2\epsilon_0} \cdot \frac{R^2}{2|z|} = \frac{1}{4\pi\epsilon_0} \frac{\sigma(\pi R^2)}{|z|} = \frac{1}{4\pi\epsilon_0} \frac{Q}{|z|}$$

As expected, at large distance, the potential due to a non-conducting charged disk is the same as that of a point charge Q . A comparison of the electric potentials of the disk and a point charge is shown in Figure 3.4.4.

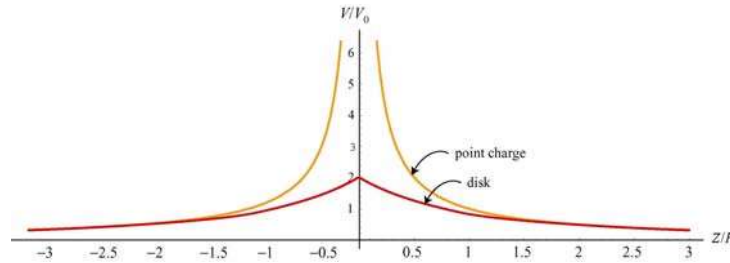

Figure 3.4.4 Comparison of the electric potentials of a non-conducting disk and a point charge. The electric potential is measured in terms of $V_0 = Q/4\pi\epsilon_0 R$.

Note that the electric potential at the center of the disk ($z = 0$) is finite, and its value is

$$V_c = \frac{\sigma R}{2\epsilon_0} = \frac{Q}{\pi R^2} \cdot \frac{R}{2\epsilon_0} = \frac{1}{4\pi\epsilon_0} \frac{2Q}{R} = 2V_0 \quad (3.5.15)$$

This is the amount of work that needs to be done to bring a unit charge from infinity and place it at the center of the disk.

The corresponding electric field at P can be obtained as:

$$E_z = -\frac{\partial V}{\partial z} = \frac{\sigma}{2\epsilon_0} \left[\frac{z}{|z|} - \frac{z}{\sqrt{R^2 + z^2}} \right] \quad (3.5.16)$$

which agrees with Eq. (2.10.18). In the limit $R \gg z$, the above equation becomes $E_z = \sigma / 2\epsilon_0$, which is the electric field for an infinitely large non-conducting sheet.

Example 3.4: Calculating Electric Field from Electric Potential

Suppose the electric potential due to a certain charge distribution can be written in Cartesian Coordinates as

$$V(x, y, z) = Ax^2y^2 + Bxyz$$

where A , B and C are constants. What is the associated electric field?

Solution:

The electric field can be found by using Eq. (3.5.3):

$$E_x = -\frac{\partial V}{\partial x} = -2Axy^2 - Byz$$

$$E_y = -\frac{\partial V}{\partial y} = -2Ax^2y - Bxz$$

$$E_z = -\frac{\partial V}{\partial z} = -Bxy$$

Therefore, the electric field is $\vec{E} = (-2Axy^2 - Byz)\hat{i} - (2Ax^2y + Bxz)\hat{j} - Bxy\hat{k}$.

3.6 Summary

- A force \vec{F} is **conservative** if the line integral of the force around a closed loop vanishes:

$$\oint \vec{F} \cdot d\vec{s} = 0$$

- The change in potential energy associated with a conservative force \vec{F} acting on an object as it moves from A to B is

$$\Delta U = U_B - U_A = -\int_A^B \vec{F} \cdot d\vec{s}$$

- The **electric potential difference** ΔV between points A and B in an electric field \vec{E} is given by

$$\Delta V = V_B - V_A = \frac{\Delta U}{q_0} = -\int_A^B \vec{E} \cdot d\vec{s}$$

The quantity represents the amount of work done per unit charge to move a test charge q_0 from point A to B , without changing its kinetic energy.

- The electric potential due to a point charge Q at a distance r away from the charge is

$$V = \frac{1}{4\pi\epsilon_0} \frac{Q}{r}$$

For a collection of charges, using the superposition principle, the electric potential is

$$V = \frac{1}{4\pi\epsilon_0} \sum_i \frac{Q_i}{r_i}$$

- The **potential energy** associated with two point charges q_1 and q_2 separated by a distance r_{12} is

$$U = \frac{1}{4\pi\epsilon_0} \frac{q_1 q_2}{r_{12}}$$

- From the electric potential V , the electric field may be obtained by taking the **gradient** of V :

$$\vec{E} = -\nabla V$$

In Cartesian coordinates, the components may be written as

$$E_x = -\frac{\partial V}{\partial x}, \quad E_y = -\frac{\partial V}{\partial y}, \quad E_z = -\frac{\partial V}{\partial z}$$

- The electric potential due to a continuous charge distribution is

$$V = \frac{1}{4\pi\epsilon_0} \int \frac{dq}{r}$$

3.7 Problem-Solving Strategy: Calculating Electric Potential

In this chapter, we showed how electric potential can be calculated for both the discrete and continuous charge distributions. Unlike electric field, electric potential is a scalar quantity. For the discrete distribution, we apply the superposition principle and sum over individual contributions:

$$V = k_e \sum_i \frac{q_i}{r_i}$$

For the continuous distribution, we must evaluate the integral

$$V = k_e \int \frac{dq}{r}$$

In analogy to the case of computing the electric field, we use the following steps to complete the integration:

(1) Start with $dV = k_e \frac{dq}{r}$.

(2) Rewrite the charge element dq as

$$dq = \begin{cases} \lambda dl & \text{(length)} \\ \sigma dA & \text{(area)} \\ \rho dV & \text{(volume)} \end{cases}$$

depending on whether the charge is distributed over a length, an area, or a volume.

(3) Substitute dq into the expression for dV .

(4) Specify an appropriate coordinate system and express the differential element (dl , dA or dV) and r in terms of the coordinates (see Table 2.1.)

(5) Rewrite dV in terms of the integration variable.

(6) Complete the integration to obtain V .

Using the result obtained for V , one may calculate the electric field by $\vec{\mathbf{E}} = -\nabla V$. Furthermore, the accuracy of the result can be readily checked by choosing a point P which lies sufficiently far away from the charge distribution. In this limit, if the charge distribution is of finite extent, the field should behave as if the distribution were a point charge, and falls off as $1/r^2$.

Below we illustrate how the above methodologies can be employed to compute the electric potential for a line of charge, a ring of charge and a uniformly charged disk.

	Charged Rod	Charged Ring	Charged disk
Figure			
(2) Express dq in terms of charge density	$dq = \lambda dx'$	$dq = \lambda dl$	$dq = \sigma dA$
(3) Substitute dq into expression for dV	$dV = k_e \frac{\lambda dx'}{r}$	$dV = k_e \frac{\lambda dl}{r}$	$dV = k_e \frac{\sigma dA}{r}$
(4) Rewrite r and the differential element in terms of the appropriate coordinates	dx' $r = \sqrt{x'^2 + y^2}$	$dl = R d\phi'$ $r = \sqrt{R^2 + z^2}$	$dA = 2\pi r' dr'$ $r = \sqrt{r'^2 + z^2}$
(5) Rewrite dV	$dV = k_e \frac{\lambda dx'}{(x'^2 + y^2)^{1/2}}$	$dV = k_e \frac{\lambda R d\phi'}{(R^2 + z^2)^{1/2}}$	$dV = k_e \frac{2\pi\sigma r' dr'}{(r'^2 + z^2)^{1/2}}$
(6) Integrate to get V	$V = \frac{\lambda}{4\pi\epsilon_0} \int_{-l/2}^{l/2} \frac{dx'}{\sqrt{x'^2 + y^2}}$ $= \frac{\lambda}{4\pi\epsilon_0} \ln \left[\frac{(\ell/2) + \sqrt{(\ell/2)^2 + y^2}}{-(\ell/2) + \sqrt{(\ell/2)^2 + y^2}} \right]$	$V = k_e \frac{R\lambda}{(R^2 + z^2)^{1/2}} \oint d\phi'$ $= k_e \frac{(2\pi R\lambda)}{\sqrt{R^2 + z^2}}$ $= k_e \frac{Q}{\sqrt{R^2 + z^2}}$	$V = k_e 2\pi\sigma \int_0^R \frac{r' dr'}{(r'^2 + z^2)^{1/2}}$ $= 2k_e\pi\sigma \left(\sqrt{z^2 + R^2} - z \right)$ $= \frac{2k_e Q}{R^2} \left(\sqrt{z^2 + R^2} - z \right)$
Derive E from V	$E_y = -\frac{\partial V}{\partial y}$ $= \frac{\lambda}{2\pi\epsilon_0 y} \frac{\ell/2}{\sqrt{(\ell/2)^2 + y^2}}$	$E_z = -\frac{\partial V}{\partial z} = \frac{k_e Q z}{(R^2 + z^2)^{3/2}}$	$E_z = -\frac{\partial V}{\partial z} = \frac{2k_e Q}{R^2} \left(\frac{z}{ z } - \frac{z}{\sqrt{z^2 + R^2}} \right)$
Point-charge limit for E	$E_y \approx \frac{k_e Q}{y^2} \quad y \gg \ell$	$E_z \approx \frac{k_e Q}{z^2} \quad z \gg R$	$E_z \approx \frac{k_e Q}{z^2} \quad z \gg R$

3.8 Solved Problems

3.8.1 Electric Potential Due to a System of Two Charges

Consider a system of two charges shown in Figure 3.8.1.

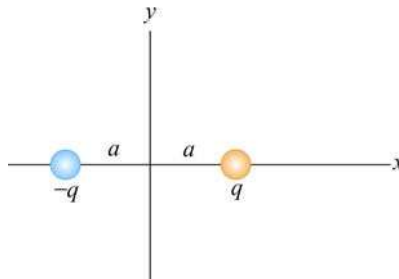

Figure 3.8.1 Electric dipole

Find the electric potential at an arbitrary point on the x axis and make a plot.

Solution:

The electric potential can be found by the superposition principle. At a point on the x axis, we have

$$V(x) = \frac{1}{4\pi\epsilon_0} \frac{q}{|x-a|} + \frac{1}{4\pi\epsilon_0} \frac{(-q)}{|x+a|} = \frac{q}{4\pi\epsilon_0} \left[\frac{1}{|x-a|} - \frac{1}{|x+a|} \right]$$

The above expression may be rewritten as

$$\frac{V(x)}{V_0} = \frac{1}{|x/a-1|} - \frac{1}{|x/a+1|}$$

where $V_0 = q/4\pi\epsilon_0 a$. The plot of the dimensionless electric potential as a function of x/a is depicted in Figure 3.8.2.

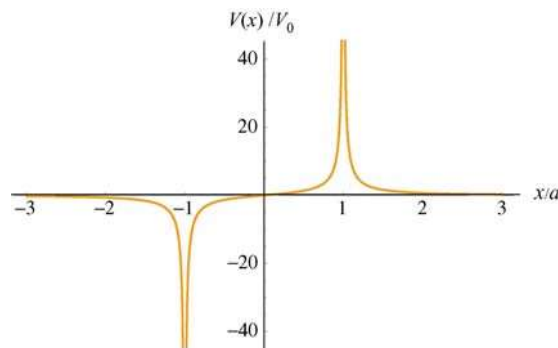

Figure 3.8.2

As can be seen from the graph, $V(x)$ diverges at $x/a = \pm 1$, where the charges are located.

3.8.2 Electric Dipole Potential

Consider an electric dipole along the y -axis, as shown in the Figure 3.8.3. Find the electric potential V at a point P in the x - y plane, and use V to derive the corresponding electric field.

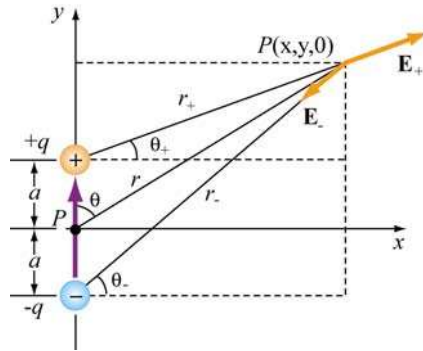

Figure 3.8.3

By superposition principle, the potential at P is given by

$$V = \sum_i V_i = \frac{1}{4\pi\epsilon_0} \left(\frac{q}{r_+} - \frac{q}{r_-} \right)$$

where $r_{\pm}^2 = r^2 + a^2 \mp 2ra \cos \theta$. If we take the limit where $r \gg a$, then

$$\frac{1}{r_{\pm}} = \frac{1}{r} \left[1 + (a/r)^2 \mp 2(a/r) \cos \theta \right]^{-1/2} = \frac{1}{r} \left[1 - \frac{1}{2} (a/r)^2 \pm (a/r) \cos \theta + \dots \right]$$

and the dipole potential can be approximated as

$$\begin{aligned} V &= \frac{q}{4\pi\epsilon_0 r} \left[1 - \frac{1}{2} (a/r)^2 + (a/r) \cos \theta - 1 + \frac{1}{2} (a/r)^2 + (a/r) \cos \theta + \dots \right] \\ &\approx \frac{q}{4\pi\epsilon_0 r} \cdot \frac{2a \cos \theta}{r} = \frac{p \cos \theta}{4\pi\epsilon_0 r^2} = \frac{\vec{p} \cdot \hat{r}}{4\pi\epsilon_0 r^2} \end{aligned}$$

where $\vec{p} = 2aq \hat{j}$ is the electric dipole moment. In spherical polar coordinates, the gradient operator is

$$\vec{\nabla} = \frac{\partial}{\partial r} \hat{r} + \frac{1}{r} \frac{\partial}{\partial \theta} \hat{\theta} + \frac{1}{r \sin \theta} \frac{\partial}{\partial \phi} \hat{\phi}$$

Since the potential is now a function of both r and θ , the electric field will have components along the \hat{r} and $\hat{\theta}$ directions. Using $\vec{E} = -\nabla V$, we have

$$E_r = -\frac{\partial V}{\partial r} = \frac{p \cos \theta}{2\pi\epsilon_0 r^3}, \quad E_\theta = -\frac{1}{r} \frac{\partial V}{\partial \theta} = \frac{p \sin \theta}{4\pi\epsilon_0 r^3}, \quad E_\phi = 0$$

3.8.3 Electric Potential of an Annulus

Consider an annulus of uniform charge density σ , as shown in Figure 3.8.4. Find the electric potential at a point P along the symmetric axis.

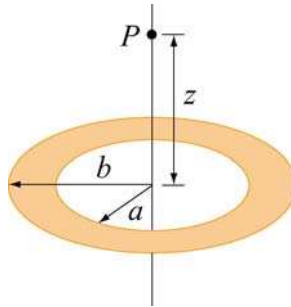

Figure 3.8.4 An annulus of uniform charge density.

Solution:

Consider a small differential element dA at a distance r away from point P . The amount of charge contained in dA is given by

$$dq = \sigma dA = \sigma(r' d\theta) dr'$$

Its contribution to the electric potential at P is

$$dV = \frac{1}{4\pi\epsilon_0} \frac{dq}{r} = \frac{1}{4\pi\epsilon_0} \frac{\sigma r' dr' d\theta}{\sqrt{r'^2 + z^2}}$$

Integrating over the entire annulus, we obtain

$$V = \frac{\sigma}{4\pi\epsilon_0} \int_a^b \int_0^{2\pi} \frac{r' dr' d\theta}{\sqrt{r'^2 + z^2}} = \frac{2\pi\sigma}{4\pi\epsilon_0} \int_a^b \frac{r' ds}{\sqrt{r'^2 + z^2}} = \frac{\sigma}{2\epsilon_0} \left[\sqrt{b^2 + z^2} - \sqrt{a^2 + z^2} \right]$$

where we have made use of the integral

$$\int \frac{ds s}{\sqrt{s^2 + z^2}} = \sqrt{s^2 + z^2}$$

Notice that in the limit $a \rightarrow 0$ and $b \rightarrow R$, the potential becomes

$$V = \frac{\sigma}{2\epsilon_0} \left[\sqrt{R^2 + z^2} - |z| \right]$$

which coincides with the result of a non-conducting disk of radius R shown in Eq. (3.5.14).

3.8.4 Charge Moving Near a Charged Wire

A thin rod extends along the z -axis from $z = -d$ to $z = d$. The rod carries a positive charge Q uniformly distributed along its length $2d$ with charge density $\lambda = Q/2d$.

- Calculate the electric potential at a point $z > d$ along the z -axis.
- What is the change in potential energy if an electron moves from $z = 4d$ to $z = 3d$?
- If the electron started out at rest at the point $z = 4d$, what is its velocity at $z = 3d$?

Solutions:

(a) For simplicity, let's set the potential to be zero at infinity, $V(\infty) = 0$. Consider an infinitesimal charge element $dq = \lambda dz'$ located at a distance z' along the z -axis. Its contribution to the electric potential at a point $z > d$ is

$$dV = \frac{\lambda}{4\pi\epsilon_0} \frac{dz'}{z - z'}$$

Integrating over the entire length of the rod, we obtain

$$V(z) = \frac{\lambda}{4\pi\epsilon_0} \int_{z+d}^{z-d} \frac{dz'}{z - z'} = \frac{\lambda}{4\pi\epsilon_0} \ln \left(\frac{z+d}{z-d} \right)$$

(b) Using the result derived in (a), the electrical potential at $z = 4d$ is

$$V(z = 4d) = \frac{\lambda}{4\pi\epsilon_0} \ln \left(\frac{4d+d}{4d-d} \right) = \frac{\lambda}{4\pi\epsilon_0} \ln \left(\frac{5}{3} \right)$$

Similarly, the electrical potential at $z = 3d$ is

$$V(z = 3d) = \frac{\lambda}{4\pi\epsilon_0} \ln\left(\frac{3d+d}{3d-d}\right) = \frac{\lambda}{4\pi\epsilon_0} \ln 2$$

The electric potential difference between the two points is

$$\Delta V = V(z = 3d) - V(z = 4d) = \frac{\lambda}{4\pi\epsilon_0} \ln\left(\frac{6}{5}\right) > 0$$

Using the fact that the electric potential difference ΔV is equal to the change in potential energy per unit charge, we have

$$\Delta U = q\Delta V = -\frac{|e|\lambda}{4\pi\epsilon_0} \ln\left(\frac{6}{5}\right) < 0$$

where $q = -|e|$ is the charge of the electron.

(c) If the electron starts out at rest at $z = 4d$ then the change in kinetic energy is

$$\Delta K = \frac{1}{2}mv_f^2$$

By conservation of energy, the change in kinetic energy is

$$\Delta K = -\Delta U = \frac{|e|\lambda}{4\pi\epsilon_0} \ln\left(\frac{6}{5}\right) > 0$$

Thus, the magnitude of the velocity at $z = 3d$ is

$$v_f = \sqrt{\frac{2|e|\lambda}{4\pi\epsilon_0 m} \ln\left(\frac{6}{5}\right)}$$

3.9 Conceptual Questions

1. What is the difference between electric potential and electric potential energy?
2. A uniform electric field is parallel to the x -axis. In what direction can a charge be displaced in this field without any external work being done on the charge?
3. Is it safe to stay in an automobile with a metal body during severe thunderstorm? Explain.

4. Why are equipotential surfaces always perpendicular to electric field lines?
5. The electric field inside a hollow, uniformly charged sphere is zero. Does this imply that the potential is zero inside the sphere?

3.10 Additional Problems

3.10.1 Cube

How much work is done to assemble eight identical point charges, each of magnitude q , at the corners of a cube of side a ?

3.10.2 Three Charges

Three charges with $q = 3.00 \times 10^{-18}$ C and $q_1 = 6 \times 10^{-6}$ C are placed on the x -axis, as shown in the figure 3.10.1. The distance between q and q_1 is $a = 0.600$ m.

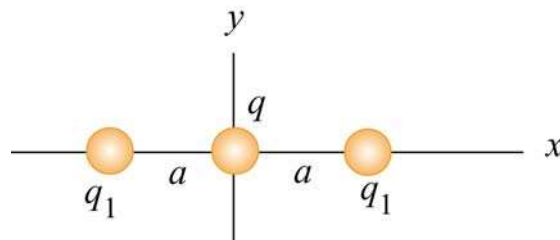

Figure 3.10.1

- (a) What is the net force exerted on q by the other two charges q_1 ?
- (b) What is the electric field at the origin due to the two charges q_1 ?
- (c) What is the electric potential at the origin due to the two charges q_1 ?

3.10.3 Work Done on Charges

Two charges $q_1 = 3.0 \mu\text{C}$ and $q_2 = -4.0 \mu\text{C}$ initially are separated by a distance $r_0 = 2.0$ cm. An external agent moves the charges until they are $r_f = 5.0$ cm apart.

- (a) How much work is done by the *electric field* in moving the charges from r_0 to r_f ? Is the work positive or negative?
- (b) How much work is done by the *external agent* in moving the charges from r_0 to r_f ? Is the work positive or negative?

- (c) What is the potential energy of the initial state where the charges are $r_0 = 2.0$ cm apart?
- (d) What is the potential energy of the final state where the charges are $r_f = 5.0$ cm apart?
- (e) What is the change in potential energy from the initial state to the final state?

3.10.4 Calculating E from V

Suppose in some region of space the electric potential is given by

$$V(x, y, z) = V_0 - E_0 z + \frac{E_0 a^3 z}{(x^2 + y^2 + z^2)^{3/2}}$$

where a is a constant with dimensions of length. Find the x , y , and the z -components of the associated electric field.

3.10.5 Electric Potential of a Rod

A rod of length L lies along the x -axis with its left end at the origin and has a non-uniform charge density $\lambda = \alpha x$, where α is a positive constant.

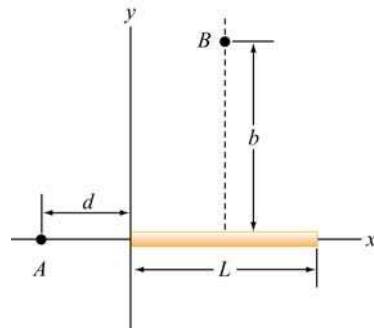

Figure 3.10.2

- (a) What are the dimensions of α ?
- (b) Calculate the electric potential at A .
- (c) Calculate the electric potential at point B that lies along the perpendicular bisector of the rod a distance b above the x -axis.

3.10.6 Electric Potential

Suppose that the electric potential in some region of space is given by

$$V(x, y, z) = V_0 \exp(-k|z|) \cos kx.$$

Find the electric field everywhere. Sketch the electric field lines in the $x-z$ plane.

3.10.7 Calculating Electric Field from the Electric Potential

Suppose that the electric potential varies along the x -axis as shown in Figure 3.10.3 below.

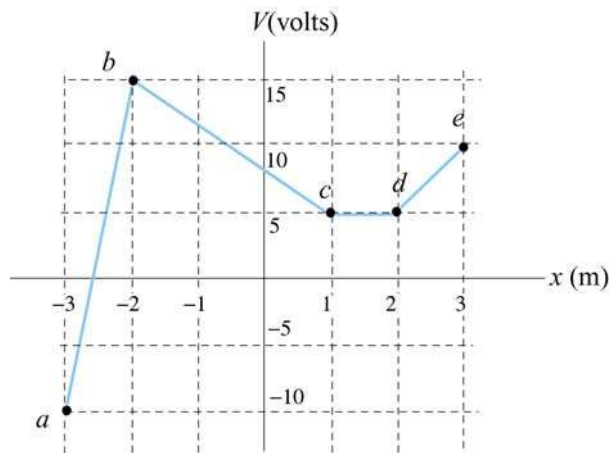

Figure 3.10.3

The potential does not vary in the y - or z -direction. Of the intervals shown (ignore the behavior at the end points of the intervals), determine the intervals in which E_x has

(a) its greatest absolute value. [Ans: 25 V/m in interval ab .]

(b) its least. [Ans: (b) 0 V/m in interval cd .]

(c) Plot E_x as a function of x .

(d) What sort of charge distributions would produce these kinds of changes in the potential? Where are they located? [Ans: sheets of charge extending in the yz direction located at points b , c , d , etc. along the x -axis. Note again that a sheet of charge with charge per unit area σ will *always* produce a jump in the normal component of the electric field of magnitude σ/ϵ_0 .]

3.10.8 Electric Potential and Electric Potential Energy

A right isosceles triangle of side a has charges q , $+2q$ and $-q$ arranged on its vertices, as shown in Figure 3.10.4.

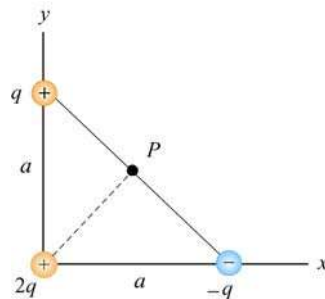

Figure 3.10.4

- What is the electric potential at point P , midway between the line connecting the $+q$ and $-q$ charges, assuming that $V = 0$ at infinity? [Ans: $q/\sqrt{2} \pi\epsilon_0 a$.]
- What is the potential energy U of this configuration of three charges? What is the significance of the sign of your answer? [Ans: $-q^2/4\sqrt{2} \pi\epsilon_0 a$, the negative sign means that work was done on the agent who assembled these charges in moving them in from infinity.]
- A fourth charge with charge $+3q$ is slowly moved in from infinity to point P . How much work must be done in this process? What is the significance of the sign of your answer? [Ans: $+3q^2/\sqrt{2} \pi\epsilon_0 a$, the positive sign means that work was done by the agent who moved this charge in from infinity.]

3.10.9. Electric Field, Potential and Energy

Three charges, $+5Q$, $-5Q$, and $+3Q$ are located on the y -axis at $y = +4a$, $y = 0$, and $y = -4a$, respectively. The point P is on the x -axis at $x = 3a$.

- How much energy did it take to assemble these charges?
- What are the x , y , and z components of the electric field \vec{E} at P ?
- What is the electric potential V at point P , taking $V = 0$ at infinity?
- A fourth charge of $+Q$ is brought to P from infinity. What are the x , y , and z components of the force \vec{F} that is exerted on it by the other three charges?
- How much work was done (by the external agent) in moving the fourth charge $+Q$ from infinity to P ?

Chapter 4

Gauss's Law

4.1 Electric Flux.....	1
4.2 Gauss's Law.....	2
Example 4.1: Infinitely Long Rod of Uniform Charge Density	7
Example 4.2: Infinite Plane of Charge.....	9
Example 4.3: Spherical Shell.....	11
Example 4.4: Non-Conducting Solid Sphere.....	13
4.3 Conductors.....	14
Example 4.5: Conductor with Charge Inside a Cavity	17
Example 4.6: Electric Potential Due to a Spherical Shell.....	18
4.4 Force on a Conductor.....	21
4.5 Summary	23
4.6 Appendix: Tensions and Pressures	24
Animation 4.1: Charged Particle Moving in a Constant Electric Field.....	25
Animation 4.2: Charged Particle at Rest in a Time-Varying Field	26
Animation 4.3: Like and Unlike Charges Hanging from Pendulums.....	28
4.7 Problem-Solving Strategies	29
4.8 Solved Problems	31
4.8.1 Two Parallel Infinite Non-Conducting Planes.....	31
4.8.2 Electric Flux Through a Square Surface.....	32
4.8.3 Gauss's Law for Gravity.....	34
4.8.4 Electric Potential of a Uniformly Charged Sphere	34
4.9 Conceptual Questions	36
4.10 Additional Problems	36
4.10.1 Non-Conducting Solid Sphere with a Cavity.....	36
4.10.2 P-N Junction.....	36
4.10.3 Sphere with Non-Uniform Charge Distribution	37
4.10.4 Thin Slab.....	37
4.10.5 Electric Potential Energy of a Solid Sphere.....	38
4.10.6 Calculating Electric Field from Electrical Potential	38

Gauss's Law

4.1 Electric Flux

In Chapter 2 we showed that the strength of an electric field is proportional to the number of field lines per area. The number of electric field lines that penetrates a given surface is called an “electric flux,” which we denote as Φ_E . The electric field can therefore be thought of as the number of lines per unit area.

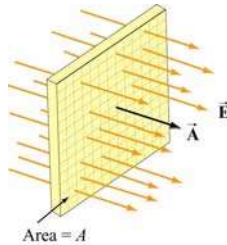

Figure 4.1.1 Electric field lines passing through a surface of area A .

Consider the surface shown in Figure 4.1.1. Let $\vec{A} = A\hat{n}$ be defined as the *area vector* having a magnitude of the area of the surface, A , and pointing in the normal direction, \hat{n} . If the surface is placed in a uniform electric field \vec{E} that points in the same direction as \hat{n} , i.e., perpendicular to the surface A , the flux through the surface is

$$\Phi_E = \vec{E} \cdot \vec{A} = \vec{E} \cdot \hat{n} A = EA \quad (4.1.1)$$

On the other hand, if the electric field \vec{E} makes an angle θ with \hat{n} (Figure 4.1.2), the electric flux becomes

$$\Phi_E = \vec{E} \cdot \vec{A} = EA \cos \theta = E_n A \quad (4.1.2)$$

where $E_n = \vec{E} \cdot \hat{n}$ is the component of \vec{E} perpendicular to the surface.

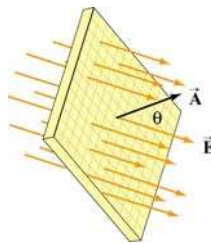

Figure 4.1.2 Electric field lines passing through a surface of area A whose normal makes an angle θ with the field.

Note that with the definition for the normal vector $\hat{\mathbf{n}}$, the electric flux Φ_E is positive if the electric field lines are leaving the surface, and negative if entering the surface.

In general, a surface S can be curved and the electric field $\vec{\mathbf{E}}$ may vary over the surface. We shall be interested in the case where the surface is *closed*. A closed surface is a surface which completely encloses a volume. In order to compute the electric flux, we divide the surface into a large number of infinitesimal area elements $\Delta\vec{\mathbf{A}}_i = \Delta A_i \hat{\mathbf{n}}_i$, as shown in Figure 4.1.3. Note that for a closed surface the unit vector $\hat{\mathbf{n}}_i$ is chosen to point in the *outward* normal direction.

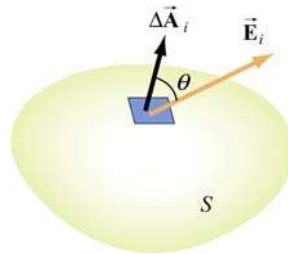

Figure 4.1.3 Electric field passing through an area element $\Delta\vec{\mathbf{A}}_i$, making an angle θ with the normal of the surface.

The electric flux through $\Delta\vec{\mathbf{A}}_i$ is

$$\Delta\Phi_E = \vec{\mathbf{E}}_i \cdot \Delta\vec{\mathbf{A}}_i = E_i \Delta A_i \cos \theta \quad (4.1.3)$$

The total flux through the entire surface can be obtained by summing over all the area elements. Taking the limit $\Delta\vec{\mathbf{A}}_i \rightarrow 0$ and the number of elements to infinity, we have

$$\Phi_E = \lim_{\Delta A_i \rightarrow 0} \sum \vec{\mathbf{E}}_i \cdot d\vec{\mathbf{A}}_i = \oiint_S \vec{\mathbf{E}} \cdot d\vec{\mathbf{A}} \quad (4.1.4)$$

where the symbol \oiint_S denotes a double integral over a *closed* surface S . In order to evaluate the above integral, we must first specify the surface and then sum over the dot product $\vec{\mathbf{E}} \cdot d\vec{\mathbf{A}}$.

4.2 Gauss's Law

Consider a positive point charge Q located at the center of a sphere of radius r , as shown in Figure 4.2.1. The electric field due to the charge Q is $\vec{\mathbf{E}} = (Q/4\pi\epsilon_0 r^2)\hat{\mathbf{r}}$, which points

in the radial direction. We enclose the charge by an imaginary sphere of radius r called the “Gaussian surface.”

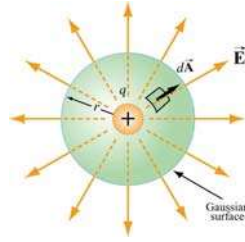

Figure 4.2.1 A spherical Gaussian surface enclosing a charge Q .

In spherical coordinates, a small surface area element on the sphere is given by (Figure 4.2.2)

$$d\vec{A} = r^2 \sin \theta d\theta d\phi \hat{r} \quad (4.2.1)$$

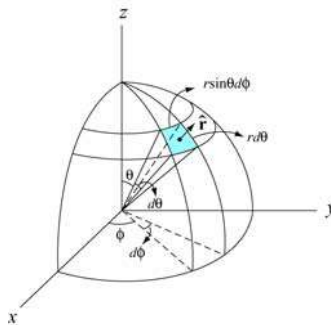

Figure 4.2.2 A small area element on the surface of a sphere of radius r .

Thus, the net electric flux through the area element is

$$d\Phi_E = \vec{E} \cdot d\vec{A} = E dA = \left(\frac{1}{4\pi\epsilon_0} \frac{Q}{r^2} \right) (r^2 \sin \theta d\theta d\phi) = \frac{Q}{4\pi\epsilon_0} \sin \theta d\theta d\phi \quad (4.2.2)$$

The total flux through the entire surface is

$$\Phi_E = \oiint_S \vec{E} \cdot d\vec{A} = \frac{Q}{4\pi\epsilon_0} \int_0^\pi \sin \theta d\theta \int_0^{2\pi} d\phi = \frac{Q}{\epsilon_0} \quad (4.2.3)$$

The same result can also be obtained by noting that a sphere of radius r has a surface area $A = 4\pi r^2$, and since the magnitude of the electric field at any point on the spherical surface is $E = Q / 4\pi\epsilon_0 r^2$, the electric flux through the surface is

$$\Phi_E = \oiint_S \vec{E} \cdot d\vec{A} = E \oiint_S dA = EA = \left(\frac{1}{4\pi\epsilon_0} \frac{Q}{r^2} \right) 4\pi r^2 = \frac{Q}{\epsilon_0} \quad (4.2.4)$$

In the above, we have chosen a sphere to be the Gaussian surface. However, it turns out that the shape of the closed surface can be arbitrarily chosen. For the surfaces shown in Figure 4.2.3, the same result ($\Phi_E = Q/\epsilon_0$) is obtained, whether the choice is S_1 , S_2 or S_3 .

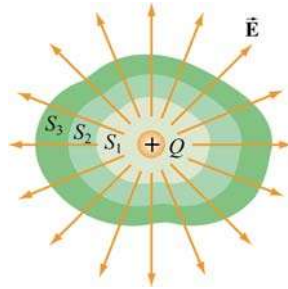

Figure 4.2.3 Different Gaussian surfaces with the same outward electric flux.

The statement that the net flux through any closed surface is proportional to the net charge enclosed is known as Gauss's law. Mathematically, Gauss's law is expressed as

$$\Phi_E = \oiint_S \vec{E} \cdot d\vec{A} = \frac{q_{\text{enc}}}{\epsilon_0} \quad (\text{Gauss's law}) \quad (4.2.5)$$

where q_{enc} is the net charge inside the surface. One way to explain why Gauss's law holds is due to note that the number of field lines that leave the charge is independent of the shape of the imaginary Gaussian surface we choose to enclose the charge.

To prove Gauss's law, we introduce the concept of the *solid angle*. Let $\Delta\vec{A}_1 = \Delta A_1 \hat{r}$ be an area element on the surface of a sphere S_1 of radius r_1 , as shown in Figure 4.2.4.

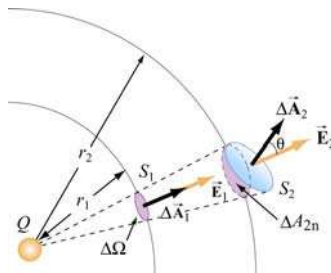

Figure 4.2.4 The area element ΔA subtends a solid angle $\Delta\Omega$.

The solid angle $\Delta\Omega$ subtended by $\Delta\vec{A}_1 = \Delta A_1 \hat{r}$ at the center of the sphere is defined as

$$\Delta\Omega \equiv \frac{\Delta A_1}{r_1^2} \quad (4.2.6)$$

Solid angles are dimensionless quantities measured in steradians (sr). Since the surface area of the sphere S_1 is $4\pi r_1^2$, the total solid angle subtended by the sphere is

$$\Omega = \frac{4\pi r_1^2}{r_1^2} = 4\pi \quad (4.2.7)$$

The concept of solid angle in three dimensions is analogous to the ordinary angle in two dimensions. As illustrated in Figure 4.2.5, an angle $\Delta\varphi$ is the ratio of the length of the arc to the radius r of a circle:

$$\Delta\varphi = \frac{\Delta s}{r} \quad (4.2.8)$$

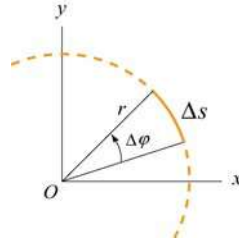

Figure 4.2.5 The arc Δs subtends an angle $\Delta\varphi$.

Since the total length of the arc is $s = 2\pi r$, the total angle subtended by the circle is

$$\varphi = \frac{2\pi r}{r} = 2\pi \quad (4.2.9)$$

In Figure 4.2.4, the area element $\Delta\vec{A}_2$ makes an angle θ with the radial unit vector \hat{r} , then the solid angle subtended by ΔA_2 is

$$\Delta\Omega = \frac{\Delta\vec{A}_2 \cdot \hat{r}}{r_2^2} = \frac{\Delta A_2 \cos\theta}{r_2^2} = \frac{\Delta A_{2n}}{r_2^2} \quad (4.2.10)$$

where $\Delta A_{2n} = \Delta A_2 \cos\theta$ is the area of the radial projection of ΔA_2 onto a second sphere S_2 of radius r_2 , concentric with S_1 .

As shown in Figure 4.2.4, the solid angle subtended is the same for both ΔA_1 and ΔA_{2n} :

$$\Delta\Omega = \frac{\Delta A_1}{r_1^2} = \frac{\Delta A_2 \cos\theta}{r_2^2} \quad (4.2.11)$$

Now suppose a point charge Q is placed at the center of the concentric spheres. The electric field strengths E_1 and E_2 at the center of the area elements ΔA_1 and ΔA_2 are related by Coulomb's law:

$$E_i = \frac{1}{4\pi\epsilon_0} \frac{Q}{r_i^2} \Rightarrow \frac{E_2}{E_1} = \frac{r_1^2}{r_2^2} \quad (4.2.12)$$

The electric flux through ΔA_1 on S_1 is

$$\Delta\Phi_1 = \vec{E} \cdot \Delta\vec{A}_1 = E_1 \Delta A_1 \quad (4.2.13)$$

On the other hand, the electric flux through ΔA_2 on S_2 is

$$\Delta\Phi_2 = \vec{E}_2 \cdot \Delta\vec{A}_2 = E_2 \Delta A_2 \cos\theta = E_1 \left(\frac{r_1^2}{r_2^2}\right) \cdot \left(\frac{r_2^2}{r_1^2}\right) \Delta A_1 = E_1 \Delta A_1 = \Phi_1 \quad (4.2.14)$$

Thus, we see that the electric flux through any area element subtending the same solid angle is constant, independent of the shape or orientation of the surface.

In summary, Gauss's law provides a convenient tool for evaluating electric field. However, its application is limited only to systems that possess certain symmetry, namely, systems with cylindrical, planar and spherical symmetry. In the table below, we give some examples of systems in which Gauss's law is applicable for determining electric field, with the corresponding Gaussian surfaces:

Symmetry	System	Gaussian Surface	Examples
Cylindrical	Infinite rod	Coaxial Cylinder	Example 4.1
Planar	Infinite plane	Gaussian "Pillbox"	Example 4.2
Spherical	Sphere, Spherical shell	Concentric Sphere	Examples 4.3 & 4.4

The following steps may be useful when applying Gauss's law:

- (1) Identify the symmetry associated with the charge distribution.
- (2) Determine the direction of the electric field, and a "Gaussian surface" on which the magnitude of the electric field is constant over portions of the surface.

(3) Divide the space into different regions associated with the charge distribution. For each region, calculate q_{enc} , the charge enclosed by the Gaussian surface.

(4) Calculate the electric flux Φ_E through the Gaussian surface for each region.

(5) Equate Φ_E with $q_{\text{enc}} / \epsilon_0$, and deduce the magnitude of the electric field.

Example 4.1: Infinitely Long Rod of Uniform Charge Density

An infinitely long rod of negligible radius has a uniform charge density λ . Calculate the electric field at a distance r from the wire.

Solution:

We shall solve the problem by following the steps outlined above.

(1) An infinitely long rod possesses cylindrical symmetry.

(2) The charge density is uniformly distributed throughout the length, and the electric field \vec{E} must be point radially away from the symmetry axis of the rod (Figure 4.2.6). The magnitude of the electric field is constant on cylindrical surfaces of radius r . Therefore, we choose a coaxial cylinder as our Gaussian surface.

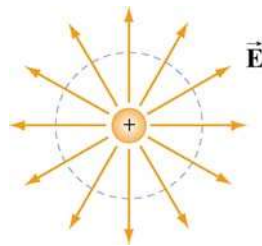

Figure 4.2.6 Field lines for an infinite uniformly charged rod (the symmetry axis of the rod and the Gaussian cylinder are perpendicular to plane of the page.)

(3) The amount of charge enclosed by the Gaussian surface, a cylinder of radius r and length ℓ (Figure 4.2.7), is $q_{\text{enc}} = \lambda \ell$.

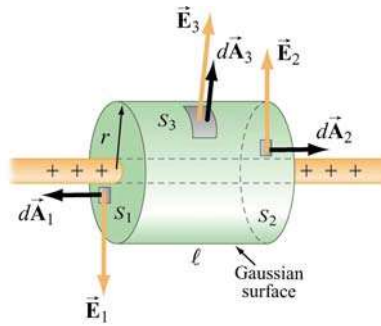

Figure 4.2.7 Gaussian surface for a uniformly charged rod.

(4) As indicated in Figure 4.2.7, the Gaussian surface consists of three parts: a two ends S_1 and S_2 plus the curved side wall S_3 . The flux through the Gaussian surface is

$$\begin{aligned}\Phi_E &= \oiint_S \vec{E} \cdot d\vec{A} = \iint_{S_1} \vec{E}_1 \cdot d\vec{A}_1 + \iint_{S_2} \vec{E}_2 \cdot d\vec{A}_2 + \iint_{S_3} \vec{E}_3 \cdot d\vec{A}_3 \\ &= 0 + 0 + E_3 A_3 = E(2\pi r \ell)\end{aligned}\quad (4.2.15)$$

where we have set $E_3 = E$. As can be seen from the figure, no flux passes through the ends since the area vectors $d\vec{A}_1$ and $d\vec{A}_2$ are perpendicular to the electric field which points in the radial direction.

(5) Applying Gauss's law gives $E(2\pi r \ell) = \lambda \ell / \epsilon_0$, or

$$E = \frac{\lambda}{2\pi\epsilon_0 r}\quad (4.2.16)$$

The result is in complete agreement with that obtained in Eq. (2.10.11) using Coulomb's law. Notice that the result is independent of the length ℓ of the cylinder, and only depends on the inverse of the distance r from the symmetry axis. The qualitative behavior of E as a function of r is plotted in Figure 4.2.8.

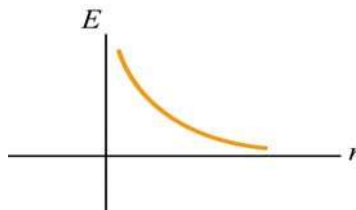

Figure 4.2.8 Electric field due to a uniformly charged rod as a function of r

Example 4.2: Infinite Plane of Charge

Consider an infinitely large non-conducting plane in the xy -plane with uniform surface charge density σ . Determine the electric field everywhere in space.

Solution:

(1) An infinitely large plane possesses a planar symmetry.

(2) Since the charge is uniformly distributed on the surface, the electric field \vec{E} must point perpendicularly away from the plane, $\vec{E} = E \hat{k}$. The magnitude of the electric field is constant on planes parallel to the non-conducting plane.

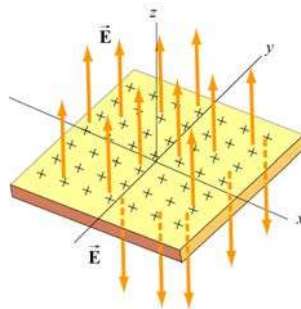

Figure 4.2.9 Electric field for uniform plane of charge

We choose our Gaussian surface to be a cylinder, which is often referred to as a “pillbox” (Figure 4.2.10). The pillbox also consists of three parts: two end-caps S_1 and S_2 , and a curved side S_3 .

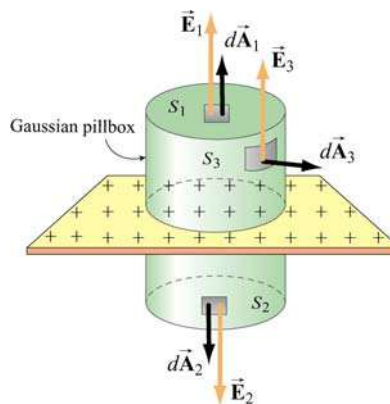

Figure 4.2.10 A Gaussian “pillbox” for calculating the electric field due to a large plane.

(3) Since the surface charge distribution on is uniform, the charge enclosed by the Gaussian “pillbox” is $q_{\text{enc}} = \sigma A$, where $A = A_1 = A_2$ is the area of the end-caps.

(4) The total flux through the Gaussian pillbox flux is

$$\begin{aligned}\Phi_E &= \oiint_S \vec{\mathbf{E}} \cdot d\vec{\mathbf{A}} = \iint_{S_1} \vec{\mathbf{E}}_1 \cdot d\vec{\mathbf{A}}_1 + \iint_{S_2} \vec{\mathbf{E}}_2 \cdot d\vec{\mathbf{A}}_2 + \iint_{S_3} \vec{\mathbf{E}}_3 \cdot d\vec{\mathbf{A}}_3 \\ &= E_1 A_1 + E_2 A_2 + 0 \\ &= (E_1 + E_2) A\end{aligned}\quad (4.2.17)$$

Since the two ends are at the same distance from the plane, by symmetry, the magnitude of the electric field must be the same: $E_1 = E_2 = E$. Hence, the total flux can be rewritten as

$$\Phi_E = 2EA \quad (4.2.18)$$

(5) By applying Gauss's law, we obtain

$$2EA = \frac{q_{\text{enc}}}{\epsilon_0} = \frac{\sigma A}{\epsilon_0}$$

which gives

$$E = \frac{\sigma}{2\epsilon_0} \quad (4.2.19)$$

In unit-vector notation, we have

$$\vec{\mathbf{E}} = \begin{cases} \frac{\sigma}{2\epsilon_0} \hat{\mathbf{k}}, & z > 0 \\ -\frac{\sigma}{2\epsilon_0} \hat{\mathbf{k}}, & z < 0 \end{cases} \quad (4.2.20)$$

Thus, we see that the electric field due to an infinite large non-conducting plane is uniform in space. The result, plotted in Figure 4.2.11, is the same as that obtained in Eq. (2.10.21) using Coulomb's law.

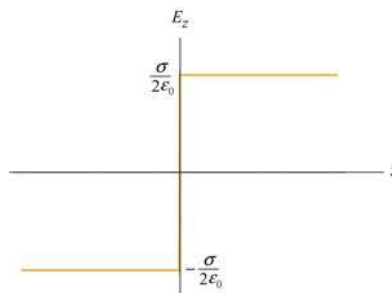

Figure 4.2.11 Electric field of an infinitely large non-conducting plane.

Note again the discontinuity in electric field as we cross the plane:

$$\Delta E_z = E_{z+} - E_{z-} = \frac{\sigma}{2\epsilon_0} - \left(-\frac{\sigma}{2\epsilon_0} \right) = \frac{\sigma}{\epsilon_0} \quad (4.2.21)$$

Example 4.3: Spherical Shell

A thin spherical shell of radius a has a charge $+Q$ evenly distributed over its surface. Find the electric field both inside and outside the shell.

Solutions:

The charge distribution is spherically symmetric, with a surface charge density $\sigma = Q/A_s = Q/4\pi a^2$, where $A_s = 4\pi a^2$ is the surface area of the sphere. The electric field \vec{E} must be radially symmetric and directed outward (Figure 4.2.12). We treat the regions $r \leq a$ and $r \geq a$ separately.

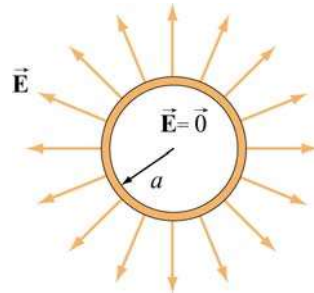

Figure 4.2.12 Electric field for uniform spherical shell of charge

Case 1: $r \leq a$

We choose our Gaussian surface to be a sphere of radius $r \leq a$, as shown in Figure 4.2.13(a).

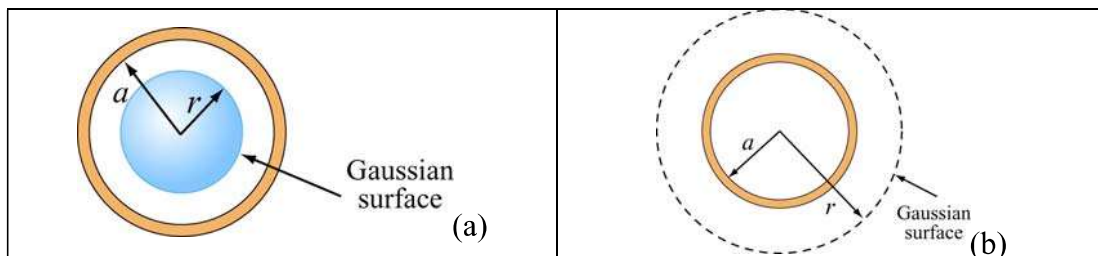

Figure 4.2.13 Gaussian surface for uniformly charged spherical shell for (a) $r < a$, and (b) $r \geq a$

The charge enclosed by the Gaussian surface is $q_{\text{enc}} = 0$ since all the charge is located on the surface of the shell. Thus, from Gauss's law, $\Phi_E = q_{\text{enc}} / \epsilon_0$, we conclude

$$E = 0, \quad r < a \quad (4.2.22)$$

Case 2: $r \geq a$

In this case, the Gaussian surface is a sphere of radius $r \geq a$, as shown in Figure 4.2.13(b). Since the radius of the "Gaussian sphere" is greater than the radius of the spherical shell, all the charge is enclosed:

$$q_{\text{enc}} = Q$$

Since the flux through the Gaussian surface is

$$\Phi_E = \oiint_S \vec{E} \cdot d\vec{A} = EA = E(4\pi r^2)$$

by applying Gauss's law, we obtain

$$E = \frac{Q}{4\pi\epsilon_0 r^2} = k_e \frac{Q}{r^2}, \quad r \geq a \quad (4.2.23)$$

Note that the field outside the sphere is the same as if all the charges were concentrated at the center of the sphere. The qualitative behavior of E as a function of r is plotted in Figure 4.2.14.

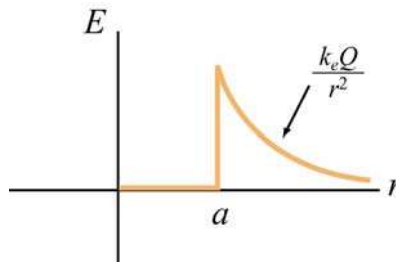

Figure 4.2.14 Electric field as a function of r due to a uniformly charged spherical shell.

As in the case of a non-conducting charged plane, we again see a discontinuity in E as we cross the boundary at $r = a$. The change, from outer to the inner surface, is given by

$$\Delta E = E_+ - E_- = \frac{Q}{4\pi\epsilon_0 a^2} - 0 = \frac{\sigma}{\epsilon_0}$$

Example 4.4: Non-Conducting Solid Sphere

An electric charge $+Q$ is uniformly distributed throughout a non-conducting solid sphere of radius a . Determine the electric field everywhere inside and outside the sphere.

Solution:

The charge distribution is spherically symmetric with the charge density given by

$$\rho = \frac{Q}{V} = \frac{Q}{(4/3)\pi a^3} \quad (4.2.24)$$

where V is the volume of the sphere. In this case, the electric field \vec{E} is radially symmetric and directed outward. The magnitude of the electric field is constant on spherical surfaces of radius r . The regions $r \leq a$ and $r \geq a$ shall be studied separately.

Case 1: $r \leq a$.

We choose our Gaussian surface to be a sphere of radius $r \leq a$, as shown in Figure 4.2.15(a).

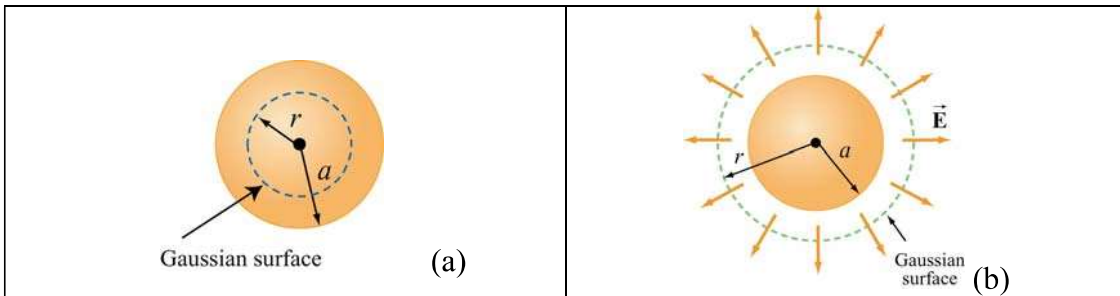

Figure 4.2.15 Gaussian surface for uniformly charged solid sphere, for (a) $r \leq a$, and (b) $r > a$.

The flux through the Gaussian surface is

$$\Phi_E = \oiint_S \vec{E} \cdot d\vec{A} = EA = E(4\pi r^2)$$

With uniform charge distribution, the charge enclosed is

$$q_{\text{enc}} = \int_V \rho dV = \rho V = \rho \left(\frac{4}{3} \pi r^3 \right) = Q \left(\frac{r^3}{a^3} \right) \quad (4.2.25)$$

which is proportional to the volume enclosed by the Gaussian surface. Applying Gauss's law $\Phi_E = q_{\text{enc}} / \epsilon_0$, we obtain

$$E(4\pi r^2) = \frac{\rho}{\epsilon_0} \left(\frac{4}{3} \pi r^3 \right)$$

or

$$E = \frac{\rho r}{3\epsilon_0} = \frac{Qr}{4\pi\epsilon_0 a^3}, \quad r \leq a \quad (4.2.26)$$

Case 2: $r \geq a$.

In this case, our Gaussian surface is a sphere of radius $r \geq a$, as shown in Figure 4.2.15(b). Since the radius of the Gaussian surface is greater than the radius of the sphere all the charge is enclosed in our Gaussian surface: $q_{\text{enc}} = Q$. With the electric flux through the Gaussian surface given by $\Phi_E = E(4\pi r^2)$, upon applying Gauss's law, we obtain $E(4\pi r^2) = Q / \epsilon_0$, or

$$E = \frac{Q}{4\pi\epsilon_0 r^2} = k_e \frac{Q}{r^2}, \quad r > a \quad (4.2.27)$$

The field outside the sphere is the same as if all the charges were concentrated at the center of the sphere. The qualitative behavior of E as a function of r is plotted in Figure 4.2.16.

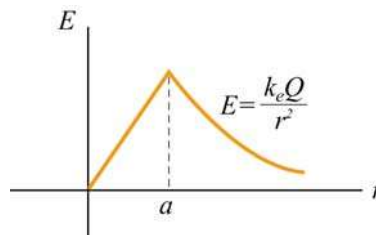

Figure 4.2.16 Electric field due to a uniformly charged sphere as a function of r .

4.3 Conductors

An insulator such as glass or paper is a material in which electrons are attached to some particular atoms and cannot move freely. On the other hand, inside a conductor, electrons are free to move around. The basic properties of a conductor are the following:

- (1) The electric field is zero inside a conductor.

If we place a solid spherical conductor in a constant external field \vec{E}_0 , the positive and negative charges will move toward the polar regions of the sphere (the regions on the left and right of the sphere in Figure 4.3.1 below), thereby inducing an electric field \vec{E}' . Inside the conductor, \vec{E}' points in the opposite direction of \vec{E}_0 . Since charges are mobile, they will continue to move until \vec{E}' completely cancels \vec{E}_0 inside the conductor. At electrostatic equilibrium, \vec{E} must vanish inside a conductor. Outside the conductor, the electric field \vec{E}' due to the induced charge distribution corresponds to a dipole field, and the total electric field is simply $\vec{E} = \vec{E}_0 + \vec{E}'$. The field lines are depicted in Figure 4.3.1.

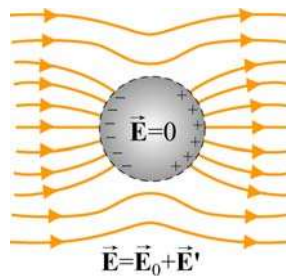

Figure 4.3.1 Placing a conductor in a uniform electric field \vec{E}_0 .

(2) Any net charge must reside on the surface.

If there were a net charge inside the conductor, then by Gauss's law (Eq. 4.3.2), \vec{E} would no longer be zero there. Therefore, all the net excess charge must flow to the surface of the conductor.

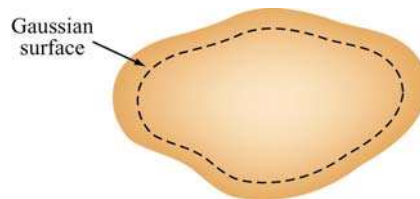

Figure 4.3.2 Gaussian surface inside a conductor. The enclosed charge is zero.

(3) The tangential component of \vec{E} is zero on the surface of a conductor.

We have already seen that for an isolated conductor, the electric field is zero in its interior. Any excess charge placed on the conductor must then distribute itself on the surface, as implied by Gauss's law.

Consider the line integral $\oint \vec{E} \cdot d\vec{s}$ around a closed path shown in Figure 4.3.3:

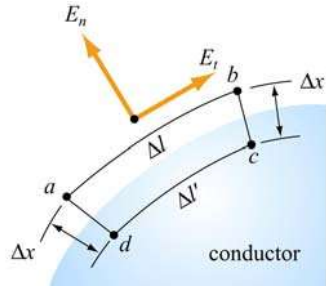

Figure 4.3.3 Normal and tangential components of electric field outside the conductor

Since the electric field \vec{E} is conservative, the line integral around the closed path $abcd$ vanishes:

$$\oint_{abcd} \vec{E} \cdot d\vec{s} = E_t(\Delta l) - E_n(\Delta x') + 0(\Delta l') + E_n(\Delta x) = 0$$

where E_t and E_n are the tangential and the normal components of the electric field, respectively, and we have oriented the segment ab so that it is parallel to E_t . In the limit where both Δx and $\Delta x' \rightarrow 0$, we have $E_t \Delta l = 0$. However, since the length element Δl is finite, we conclude that the tangential component of the electric field on the surface of a conductor vanishes:

$$\boxed{E_t = 0 \text{ (on the surface of a conductor)}} \quad (4.3.1)$$

This implies that the surface of a conductor in electrostatic equilibrium is an *equipotential surface*. To verify this claim, consider two points A and B on the surface of a conductor. Since the tangential component $E_t = 0$, the potential difference is

$$V_B - V_A = -\int_A^B \vec{E} \cdot d\vec{s} = 0$$

because \vec{E} is perpendicular to $d\vec{s}$. Thus, points A and B are at the same potential with $V_A = V_B$.

(4) \vec{E} is normal to the surface just outside the conductor.

If the tangential component of \vec{E} is initially non-zero, charges will then move around until it vanishes. Hence, only the normal component survives.

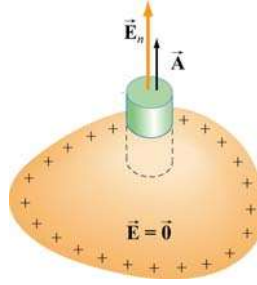

Figure 4.3.3 Gaussian “pillbox” for computing the electric field outside the conductor.

To compute the field strength just outside the conductor, consider the Gaussian pillbox drawn in Figure 4.3.3. Using Gauss’s law, we obtain

$$\Phi_E = \oiint_S \vec{\mathbf{E}} \cdot d\vec{\mathbf{A}} = E_n A + (0) \cdot A = \frac{\sigma A}{\epsilon_0} \quad (4.3.2)$$

or

$$\boxed{E_n = \frac{\sigma}{\epsilon_0}} \quad (4.3.3)$$

The above result holds for a conductor of arbitrary shape. The pattern of the electric field line directions for the region near a conductor is shown in Figure 4.3.4.

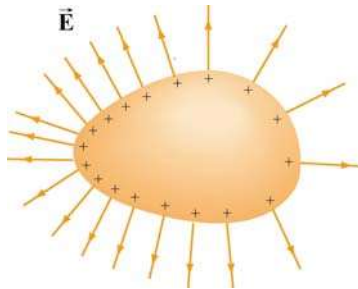

Figure 4.3.4 Just outside the conductor, $\vec{\mathbf{E}}$ is always perpendicular to the surface.

As in the examples of an infinitely large non-conducting plane and a spherical shell, the normal component of the electric field exhibits a discontinuity at the boundary:

$$\Delta E_n = E_n^{(+)} - E_n^{(-)} = \frac{\sigma}{\epsilon_0} - 0 = \frac{\sigma}{\epsilon_0}$$

Example 4.5: Conductor with Charge Inside a Cavity

Consider a hollow conductor shown in Figure 4.3.5 below. Suppose the net charge carried by the conductor is $+Q$. In addition, there is a charge q inside the cavity. What is the charge on the outer surface of the conductor?

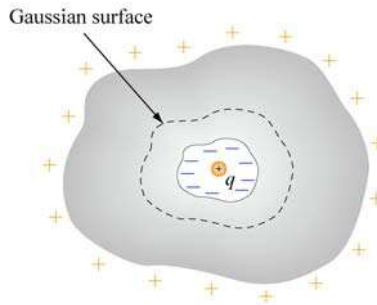

Figure 4.3.5 Conductor with a cavity

Since the electric field inside a conductor must be zero, the net charge enclosed by the Gaussian surface shown in Figure 4.3.5 must be zero. This implies that a charge $-q$ must have been induced on the cavity surface. Since the conductor itself has a charge $+Q$, the amount of charge on the outer surface of the conductor must be $Q + q$.

Example 4.6: Electric Potential Due to a Spherical Shell

Consider a metallic spherical shell of radius a and charge Q , as shown in Figure 4.3.6.

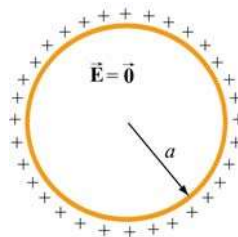

Figure 4.3.6 A spherical shell of radius a and charge Q .

- (a) Find the electric potential everywhere.
- (b) Calculate the potential energy of the system.

Solution:

- (a) In Example 4.3, we showed that the electric field for a spherical shell of is given by

$$\vec{\mathbf{E}} = \begin{cases} \frac{Q}{4\pi\epsilon_0 r^2} \hat{\mathbf{r}}, & r > a \\ 0, & r < a \end{cases}$$

The electric potential may be calculated by using Eq. (3.1.9):

$$V_B - V_A = -\int_A^B \vec{\mathbf{E}} \cdot d\vec{\mathbf{s}}$$

For $r > a$, we have

$$V(r) - V(\infty) = -\int_{\infty}^r \frac{Q}{4\pi\epsilon_0 r'^2} dr' = \frac{1}{4\pi\epsilon_0} \frac{Q}{r} = k_e \frac{Q}{r} \quad (4.3.4)$$

where we have chosen $V(\infty) = 0$ as our reference point. On the other hand, for $r < a$, the potential becomes

$$\begin{aligned} V(r) - V(\infty) &= -\int_{\infty}^a dr E(r > a) - \int_a^r E(r < a) \\ &= -\int_{\infty}^a dr \frac{Q}{4\pi\epsilon_0 r^2} = \frac{1}{4\pi\epsilon_0} \frac{Q}{a} = k_e \frac{Q}{a} \end{aligned} \quad (4.3.5)$$

A plot of the electric potential is shown in Figure 4.3.7. Note that the potential V is constant inside a conductor.

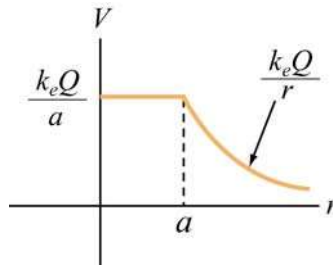

Figure 4.3.7 Electric potential as a function of r for a spherical conducting shell

(b) The potential energy U can be thought of as the work that needs to be done to build up the system. To charge up the sphere, an external agent must bring charge from infinity and deposit it onto the surface of the sphere.

Suppose the charge accumulated on the sphere at some instant is q . The potential at the surface of the sphere is then $V = q/4\pi\epsilon_0 a$. The amount of work that must be done by an external agent to bring charge dq from infinity and deposit it on the sphere is

$$dW_{\text{ext}} = Vdq = \left(\frac{q}{4\pi\epsilon_0 a} \right) dq \quad (4.3.6)$$

Therefore, the total amount of work needed to charge the sphere to Q is

$$W_{\text{ext}} = \int_0^Q dq \frac{q}{4\pi\epsilon_0 a} = \frac{Q^2}{8\pi\epsilon_0 a} \quad (4.3.7)$$

Since $V = Q/4\pi\epsilon_0 a$ and $W_{\text{ext}} = U$, the above expression is simplified to

$$\boxed{U = \frac{1}{2} QV} \quad (4.3.8)$$

The result can be contrasted with the case of a point charge. The work required to bring a point charge Q from infinity to a point where the electric potential due to other charges is V would be $W_{\text{ext}} = QV$. Therefore, for a point charge Q , the potential energy is $U=QV$.

Now, suppose two metal spheres with radii r_1 and r_2 are connected by a thin conducting wire, as shown in Figure 4.3.8.

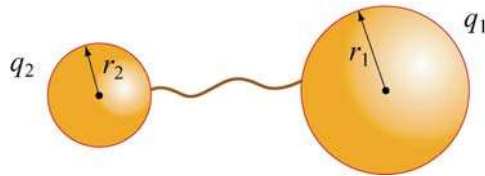

Figure 4.3.8 Two conducting spheres connected by a wire.

Charge will continue to flow until equilibrium is established such that both spheres are at the same potential $V_1 = V_2 = V$. Suppose the charges on the spheres at equilibrium are q_1 and q_2 . Neglecting the effect of the wire that connects the two spheres, the equipotential condition implies

$$V = \frac{1}{4\pi\epsilon_0} \frac{q_1}{r_1} = \frac{1}{4\pi\epsilon_0} \frac{q_2}{r_2}$$

or

$$\frac{q_1}{r_1} = \frac{q_2}{r_2} \quad (4.3.9)$$

assuming that the two spheres are very far apart so that the charge distributions on the surfaces of the conductors are uniform. The electric fields can be expressed as

$$E_1 = \frac{1}{4\pi\epsilon_0} \frac{q_1}{r_1^2} = \frac{\sigma_1}{\epsilon_0}, \quad E_2 = \frac{1}{4\pi\epsilon_0} \frac{q_2}{r_2^2} = \frac{\sigma_2}{\epsilon_0} \quad (4.3.10)$$

where σ_1 and σ_2 are the surface charge densities on spheres 1 and 2, respectively. The two equations can be combined to yield

$$\boxed{\frac{E_1}{E_2} = \frac{\sigma_1}{\sigma_2} = \frac{r_2}{r_1}} \quad (4.3.11)$$

With the surface charge density being inversely proportional to the radius, we conclude that the regions with the smallest radii of curvature have the greatest σ . Thus, the electric field strength on the surface of a conductor is greatest at the sharpest point. The design of a lightning rod is based on this principle.

4.4 Force on a Conductor

We have seen that at the boundary surface of a conductor with a uniform charge density σ , the tangential component of the electric field is zero, and hence, continuous, while the normal component of the electric field exhibits discontinuity, with $\Delta E_n = \sigma / \epsilon_0$. Consider a small patch of charge on a conducting surface, as shown in Figure 4.4.1.

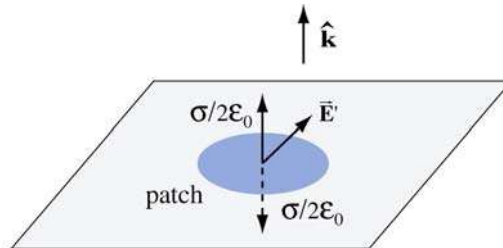

Figure 4.4.1 Force on a conductor

What is the force experienced by this patch? To answer this question, let's write the total electric field anywhere outside the surface as

$$\vec{E} = \vec{E}_{\text{patch}} + \vec{E}' \quad (4.4.1)$$

where \vec{E}_{patch} is the electric field due to charge on the patch, and \vec{E}' is the electric field due to all other charges. Since by Newton's third law, the patch cannot exert a force on itself, the force on the patch must come solely from \vec{E}' . Assuming the patch to be a flat surface, from Gauss's law, the electric field due to the patch is

$$\vec{\mathbf{E}}_{\text{patch}} = \begin{cases} +\frac{\sigma}{2\epsilon_0} \hat{\mathbf{k}}, & z > 0 \\ -\frac{\sigma}{2\epsilon_0} \hat{\mathbf{k}}, & z < 0 \end{cases} \quad (4.4.2)$$

By superposition principle, the electric field above the conducting surface is

$$\vec{\mathbf{E}}_{\text{above}} = \left(\frac{\sigma}{2\epsilon_0} \right) \hat{\mathbf{k}} + \vec{\mathbf{E}}' \quad (4.4.3)$$

Similarly, below the conducting surface, the electric field is

$$\vec{\mathbf{E}}_{\text{below}} = -\left(\frac{\sigma}{2\epsilon_0} \right) \hat{\mathbf{k}} + \vec{\mathbf{E}}' \quad (4.4.4)$$

Notice that $\vec{\mathbf{E}}'$ is continuous across the boundary. This is due to the fact that if the patch were removed, the field in the remaining “hole” exhibits no discontinuity. Using the two equations above, we find

$$\vec{\mathbf{E}}' = \frac{1}{2} (\vec{\mathbf{E}}_{\text{above}} + \vec{\mathbf{E}}_{\text{below}}) = \vec{\mathbf{E}}_{\text{avg}} \quad (4.4.5)$$

In the case of a conductor, with $\vec{\mathbf{E}}_{\text{above}} = (\sigma / \epsilon_0) \hat{\mathbf{k}}$ and $\vec{\mathbf{E}}_{\text{below}} = 0$, we have

$$\vec{\mathbf{E}}_{\text{avg}} = \frac{1}{2} \left(\frac{\sigma}{\epsilon_0} \hat{\mathbf{k}} + 0 \right) = \frac{\sigma}{2\epsilon_0} \hat{\mathbf{k}} \quad (4.4.6)$$

Thus, the force acting on the patch is

$$\vec{\mathbf{F}} = q\vec{\mathbf{E}}_{\text{avg}} = (\sigma A) \frac{\sigma}{2\epsilon_0} \hat{\mathbf{k}} = \frac{\sigma^2 A}{2\epsilon_0} \hat{\mathbf{k}} \quad (4.4.7)$$

where A is the area of the patch. This is precisely the force needed to drive the charges on the surface of a conductor to an equilibrium state where the electric field just outside the conductor takes on the value σ / ϵ_0 and vanishes inside. Note that irrespective of the sign of σ , the force tends to pull the patch into the field.

Using the result obtained above, we may define the electrostatic pressure on the patch as

$$P = \frac{F}{A} = \frac{\sigma^2}{2\epsilon_0} = \frac{1}{2} \epsilon_0 \left(\frac{\sigma}{\epsilon_0} \right)^2 = \frac{1}{2} \epsilon_0 E^2 \quad (4.4.8)$$

where E is the magnitude of the field just above the patch. The pressure is being transmitted via the electric field.

4.5 Summary

- The **electric flux** that passes through a surface characterized by the area vector $\vec{A} = A \hat{n}$ is

$$\Phi_E = \vec{E} \cdot \vec{A} = EA \cos \theta$$

where θ is the angle between the electric field \vec{E} and the unit vector \hat{n} .

- In general, the electric flux through a surface is

$$\Phi_E = \iint_S \vec{E} \cdot d\vec{A}$$

- **Gauss's law** states that the electric flux through any closed Gaussian surface is proportional to the total charge enclosed by the surface:

$$\Phi_E = \oiint_S \vec{E} \cdot d\vec{A} = \frac{q_{\text{enc}}}{\epsilon_0}$$

Gauss's law can be used to calculate the electric field for a system that possesses planar, cylindrical or spherical symmetry.

- The normal component of the electric field exhibits discontinuity, with $\Delta E_n = \sigma / \epsilon_0$, when crossing a boundary with surface charge density σ .
- The basic properties of a **conductor** are (1) The electric field inside a conductor is zero; (2) any net charge must reside on the surface of the conductor; (3) the surface of a conductor is an equipotential surface, and the tangential component of the electric field on the surface is zero; and (4) just outside the conductor, the electric field is normal to the surface.
- **Electrostatic pressure** on a conducting surface is

$$P = \frac{F}{A} = \frac{\sigma^2}{2\epsilon_0} = \frac{1}{2}\epsilon_0 \left(\frac{\sigma}{\epsilon_0}\right)^2 = \frac{1}{2}\epsilon_0 E^2$$

4.6 Appendix: Tensions and Pressures

In Section 4.4, the pressure transmitted by the electric field on a conducting surface was derived. We now consider a more general case where a closed surface (an imaginary box) is placed in an electric field, as shown in Figure 4.6.1.

If we look at the top face of the imaginary box, there is an electric field pointing in the outward normal direction of that face. From Faraday's field theory perspective, we would say that the field on that face transmits a tension along itself across the face, thereby resulting in an *upward pull*, just as if we had attached a string under tension to that face to pull it upward. Similarly, if we look at the bottom face of the imaginary box, the field on that face is anti-parallel to the outward normal of the face, and according to Faraday's interpretation, we would again say that the field on the bottom face transmits a tension along itself, giving rise to a *downward pull*, just as if a string has been attached to that face to pull it downward. (The actual determination of the direction of the force requires an advanced treatment using the Maxwell's stress tensor.) Note that this is a *pull* parallel to the outward normal of the bottom face, regardless of whether the field is into the surface or out of the surface.

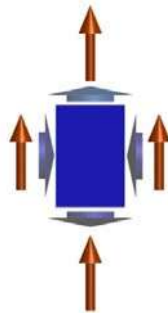

Figure 4.6.1 An imaginary box in an electric field (long orange vectors). The short vectors indicate the directions of stresses transmitted by the field, either pressures (on the left or right faces of the box) or tensions (on the top and bottom faces of the box).

For the left side of the imaginary box, the field on that face is perpendicular to the outward normal of that face, and Faraday would have said that the field on that face transmits a pressure perpendicular to itself, causing a *push* to the *right*. Similarly, for the right side of the imaginary box, the field on that face is perpendicular to the outward normal of the face, and the field would transmit a pressure perpendicular to itself. In this case, there is a *push* to the *left*.

Note that the term “tension” is used when the stress transmitted by the field is parallel (or anti-parallel) to the outward normal of the surface, and “pressure” when it is perpendicular to the outward normal. The magnitude of these pressures and tensions on the various faces of the imaginary surface in Figure 4.6.1 is given by $\epsilon_0 E^2 / 2$ for the electric field. This quantity has units of force per unit area, or pressure. It is also the energy density stored in the electric field since energy per unit volume has the same units as pressure.

Animation 4.1: Charged Particle Moving in a Constant Electric Field

As an example of the stresses transmitted by electric fields, and of the interchange of energy between fields and particles, consider a positive electric charge $q > 0$ moving in a constant electric field.

Suppose the charge is initially moving upward along the positive z -axis in a constant background field $\vec{E} = -E_0 \hat{k}$. Since the charge experiences a constant downward force $\vec{F}_e = q\vec{E} = -qE_0 \hat{k}$, it eventually comes to rest (say, at the origin $z = 0$), and then moves back down the negative z -axis. This motion and the fields that accompany it are shown in Figure 4.6.2, at two different times.

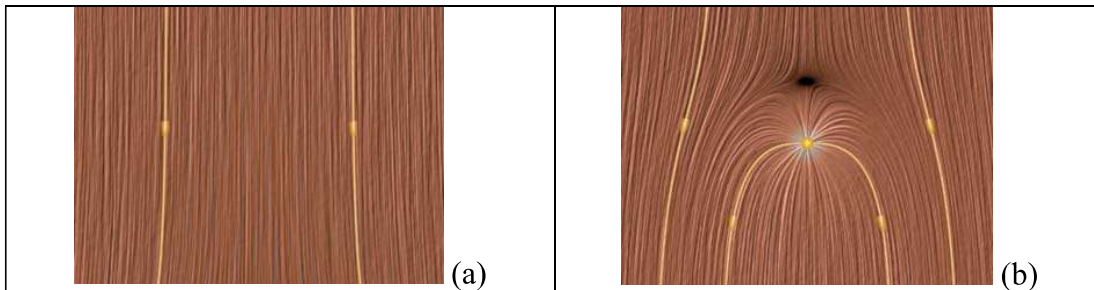

Figure 4.6.2 A positive charge moving in a constant electric field which points downward. (a) The total field configuration when the charge is still out of sight on the negative z -axis. (b) The total field configuration when the charge comes to rest at the origin, before it moves back down the negative z -axis.

How do we interpret the motion of the charge in terms of the stresses transmitted by the fields? Faraday would have described the downward force on the charge in Figure 4.6.2(b) as follows: Let the charge be surrounded by an imaginary sphere centered on it, as shown in Figure 4.6.3. The field lines piercing the lower half of the sphere transmit a tension that is parallel to the field. This is a stress pulling downward on the charge from below. The field lines draped over the top of the imaginary sphere transmit a pressure perpendicular to themselves. This is a stress pushing down on the charge from above. The total effect of these stresses is a net downward force on the charge.

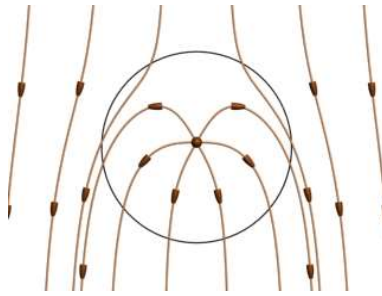

Figure 4.6.3 An electric charge in a constant downward electric field. We surround the charge by an imaginary sphere in order to discuss the stresses transmitted across the surface of that sphere by the electric field.

Viewing the animation of Figure 4.6.2 greatly enhances Faraday's interpretation of the stresses in the static image. As the charge moves upward, it is apparent in the animation that the electric field lines are generally compressed above the charge and stretched below the charge. This field configuration enables the transmission of a downward force to the moving charge we can see as well as an upward force to the charges that produce the constant field, which we cannot see. The overall appearance of the upward motion of the charge through the electric field is that of a point being forced into a resisting medium, with stresses arising in that medium as a result of that encroachment.

The kinetic energy of the upwardly moving charge is decreasing as more and more energy is stored in the compressed electrostatic field, and conversely when the charge is moving downward. Moreover, because the field line motion in the animation is in the direction of the energy flow, we can explicitly see the electromagnetic energy flow away from the charge into the surrounding field when the charge is slowing. Conversely, we see the electromagnetic energy flow back to the charge from the surrounding field when the charge is being accelerated back down the z -axis by the energy released from the field.

Finally, consider momentum conservation. The moving charge in the animation of Figure 4.6.2 completely reverses its direction of motion over the course of the animation. How do we conserve momentum in this process? Momentum is conserved because momentum in the positive z -direction is transmitted from the moving charge to the charges that are generating the constant downward electric field (not shown). This is obvious from the field configuration shown in Figure 4.6.3. The field stress, which pushes downward on the charge, is accompanied by a stress pushing upward on the charges generating the constant field.

Animation 4.2: Charged Particle at Rest in a Time-Varying Field

As a second example of the stresses transmitted by electric fields, consider a positive point charge sitting at rest at the origin in an external field which is constant in space but varies in time. This external field is uniform varies according to the equation

$$\vec{\mathbf{E}} = -E_0 \sin^4\left(\frac{2\pi t}{T}\right) \hat{\mathbf{k}} \quad (4.6.1)$$

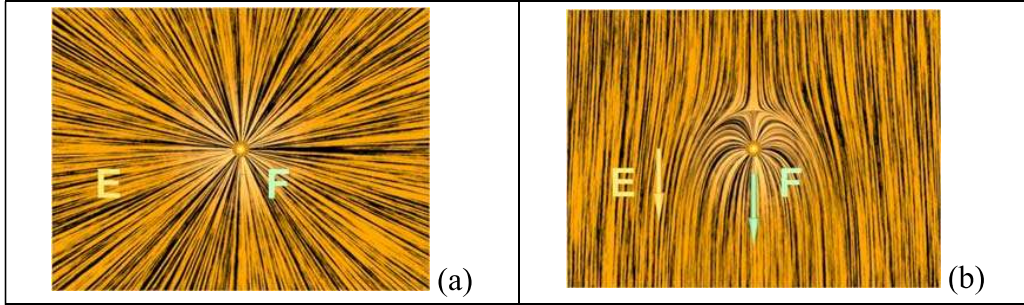

Figure 4.6.4 Two frames of an animation of the electric field around a positive charge sitting at rest in a time-changing electric field that points downward. The orange vector is the electric field and the white vector is the force on the point charge.

Figure 4.6.4 shows two frames of an animation of the total electric field configuration for this situation. Figure 4.6.4(a) is at $t = 0$, when the vertical electric field is zero. Frame 4.6.4(b) is at a quarter period later, when the downward electric field is at a maximum. As in Figure 4.6.3 above, we interpret the field configuration in Figure 4.6.4(b) as indicating a net downward force on the stationary charge. The animation of Figure 4.6.4 shows dramatically the inflow of energy into the neighborhood of the charge as the external electric field grows in time, with a resulting build-up of stress that transmits a downward force to the positive charge.

We can estimate the magnitude of the force on the charge in Figure 4.6.4(b) as follows. At the time shown in Figure 4.6.4(b), the distance r_0 above the charge at which the electric field of the charge is equal and opposite to the constant electric field is determined by the equation

$$E_0 = \frac{q}{4\pi \epsilon_0 r_0^2} \quad (4.6.2)$$

The surface area of a sphere of this radius is $A = 4\pi r_0^2 = q / \epsilon_0 E_0$. Now according to Eq. (4.4.8) the pressure (force per unit area) and/or tension transmitted across the surface of this sphere surrounding the charge is of the order of $\epsilon_0 E^2 / 2$. Since the electric field on the surface of the sphere is of order E_0 , the total force transmitted by the field is of order $\epsilon_0 E_0^2 / 2$ times the area of the sphere, or $(\epsilon_0 E_0^2 / 2)(4\pi r_0^2) = (\epsilon_0 E_0^2 / 2)(q / \epsilon_0 E_0) \approx q E_0$, as we expect.

Of course this net force is a combination of a pressure pushing down on the top of the sphere and a tension pulling down across the bottom of the sphere. However, the rough estimate that we have just made demonstrates that the pressures and tensions transmitted

across the surface of this sphere surrounding the charge are plausibly of order $\epsilon_0 E^2 / 2$, as we claimed in Eq. (4.4.8).

Animation 4.3: Like and Unlike Charges Hanging from Pendulums

Consider two charges hanging from pendulums whose supports can be moved closer or further apart by an external agent. First, suppose the charges both have the same sign, and therefore repel.

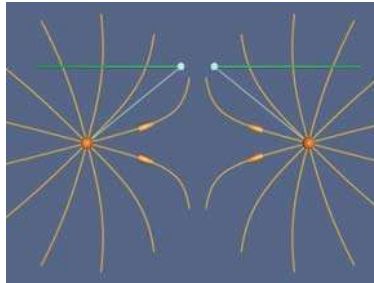

Figure 4.6.5 Two pendulums from which are suspended charges of the same sign.

Figure 4.6.5 shows the situation when an external agent tries to move the supports (from which the two positive charges are suspended) together. The force of gravity is pulling the charges down, and the force of electrostatic repulsion is pushing them apart on the radial line joining them. The behavior of the electric fields in this situation is an example of an electrostatic pressure transmitted perpendicular to the field. That pressure tries to keep the two charges apart in this situation, as the external agent controlling the pendulum supports tries to move them together. When we move the supports together the charges are pushed apart by the pressure transmitted perpendicular to the electric field. We artificially terminate the field lines at a fixed distance from the charges to avoid visual confusion.

In contrast, suppose the charges are of opposite signs, and therefore attract. Figure 4.6.6 shows the situation when an external agent moves the supports (from which the two positive charges are suspended) together. The force of gravity is pulling the charges down, and the force of electrostatic attraction is pulling them together on the radial line joining them. The behavior of the electric fields in this situation is an example of the tension transmitted parallel to the field. That tension tries to pull the two unlike charges together in this situation.

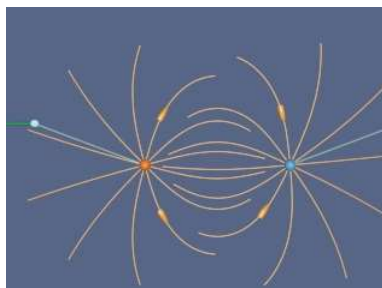

Figure 4.6.6 Two pendulums with suspended charges of opposite sign.

When we move the supports together the charges are pulled together by the tension transmitted parallel to the electric field. We artificially terminate the field lines at a fixed distance from the charges to avoid visual confusion.

4.7 Problem-Solving Strategies

In this chapter, we have shown how electric field can be computed using Gauss's law:

$$\Phi_E = \oiint_S \vec{\mathbf{E}} \cdot d\vec{\mathbf{A}} = \frac{q_{\text{enc}}}{\epsilon_0}$$

The procedures are outlined in Section 4.2. Below we summarize how the above procedures can be employed to compute the electric field for a line of charge, an infinite plane of charge and a uniformly charged solid sphere.

System	Infinite line of charge	Infinite plane of charge	Uniformly charged solid sphere
Figure			
Identify the symmetry	Cylindrical	Planar	Spherical
Determine the direction of \vec{E}			
Divide the space into different regions	$r > 0$	$z > 0$ and $z < 0$	$r \leq a$ and $r \geq a$
Choose Gaussian surface	 Coaxial cylinder	 Gaussian pillbox	 Concentric sphere
Calculate electric flux	$\Phi_E = E(2\pi r l)$	$\Phi_E = EA + EA = 2EA$	$\Phi_E = E(4\pi r^2)$
Calculate enclosed charge q_{in}	$q_{enc} = \lambda l$	$q_{enc} = \sigma A$	$q_{enc} = \begin{cases} Q(r/a)^3 & r \leq a \\ Q & r \geq a \end{cases}$
Apply Gauss's law $\Phi_E = q_{in} / \epsilon_0$ to find E	$E = \frac{\lambda}{2\pi\epsilon_0 r}$	$E = \frac{\sigma}{2\epsilon_0}$	$E = \begin{cases} \frac{Qr}{4\pi\epsilon_0 a^3}, & r \leq a \\ \frac{Q}{4\pi\epsilon_0 r^2}, & r \geq a \end{cases}$

4.8 Solved Problems

4.8.1 Two Parallel Infinite Non-Conducting Planes

Two parallel infinite non-conducting planes lying in the xy -plane are separated by a distance d . Each plane is uniformly charged with equal but opposite surface charge densities, as shown in Figure 4.8.1. Find the electric field everywhere in space.

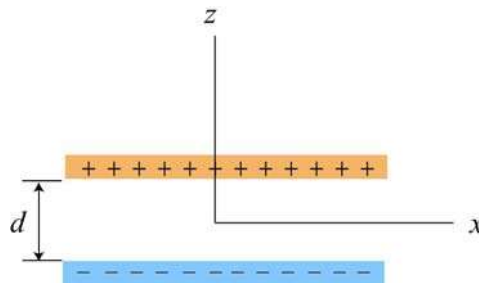

Figure 4.8.1 Positive and negative uniformly charged infinite planes

Solution:

The electric field due to the two planes can be found by applying the superposition principle to the result obtained in Example 4.2 for one plane. Since the planes carry equal but opposite surface charge densities, both fields have equal magnitude:

$$E_+ = E_- = \frac{\sigma}{2\epsilon_0}$$

The field of the positive plane points away from the positive plane and the field of the negative plane points towards the negative plane (Figure 4.8.2)

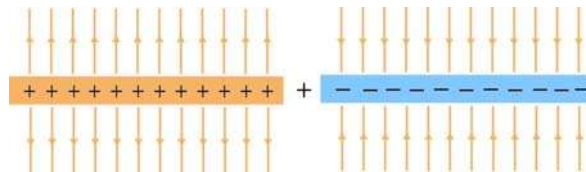

Figure 4.8.2 Electric field of positive and negative planes

Therefore, when we add these fields together, we see that the field outside the parallel planes is zero, and the field between the planes has twice the magnitude of the field of either plane.

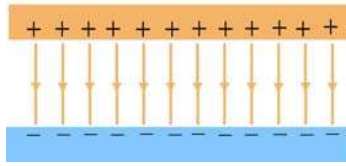

Figure 4.8.3 Electric field of two parallel planes

The electric field of the positive and the negative planes are given by

$$\vec{E}_+ = \begin{cases} +\frac{\sigma}{2\epsilon_0} \hat{\mathbf{k}}, & z > d/2 \\ -\frac{\sigma}{2\epsilon_0} \hat{\mathbf{k}}, & z < d/2 \end{cases}, \quad \vec{E}_- = \begin{cases} -\frac{\sigma}{2\epsilon_0} \hat{\mathbf{k}}, & z > -d/2 \\ +\frac{\sigma}{2\epsilon_0} \hat{\mathbf{k}}, & z < -d/2 \end{cases}$$

Adding these two fields together then yields

$$\vec{E} = \begin{cases} 0 \hat{\mathbf{k}}, & z > d/2 \\ -\frac{\sigma}{\epsilon_0} \hat{\mathbf{k}}, & d/2 > z > -d/2 \\ 0 \hat{\mathbf{k}}, & z < -d/2 \end{cases} \quad (4.8.1)$$

Note that the magnitude of the electric field between the plates is $E = \sigma / \epsilon_0$, which is twice that of a single plate, and vanishes in the regions $z > d/2$ and $z < -d/2$.

4.8.2 Electric Flux Through a Square Surface

(a) Compute the electric flux through a square surface of edges $2l$ due to a charge $+Q$ located at a perpendicular distance l from the center of the square, as shown in Figure 4.8.4.

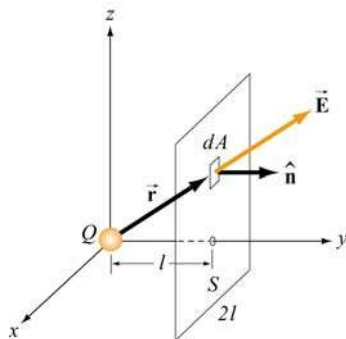

Figure 4.8.4 Electric flux through a square surface

(b) Using the result obtained in (a), if the charge $+Q$ is now at the center of a cube of side $2l$ (Figure 4.8.5), what is the total flux emerging from all the six faces of the closed surface?

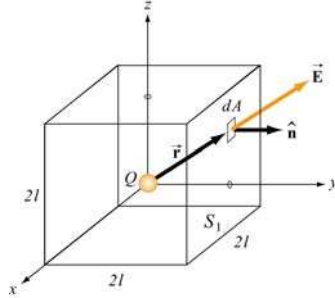

Figure 4.8.5 Electric flux through the surface of a cube

Solutions:

(a) The electric field due to the charge $+Q$ is

$$\vec{\mathbf{E}} = \frac{1}{4\pi\epsilon_0} \frac{Q}{r^2} \hat{\mathbf{r}} = \frac{1}{4\pi\epsilon_0} \frac{Q}{r^2} \left(\frac{x\hat{\mathbf{i}} + y\hat{\mathbf{j}} + z\hat{\mathbf{k}}}{r} \right)$$

where $r = (x^2 + y^2 + z^2)^{1/2}$ in Cartesian coordinates. On the surface S , $y = l$ and the area element is $d\vec{\mathbf{A}} = dA\hat{\mathbf{j}} = (dx dz)\hat{\mathbf{j}}$. Since $\hat{\mathbf{i}} \cdot \hat{\mathbf{j}} = \hat{\mathbf{j}} \cdot \hat{\mathbf{k}} = 0$ and $\hat{\mathbf{j}} \cdot \hat{\mathbf{j}} = 1$, we have

$$\vec{\mathbf{E}} \cdot d\vec{\mathbf{A}} = \frac{Q}{4\pi\epsilon_0 r^2} \left(\frac{x\hat{\mathbf{i}} + y\hat{\mathbf{j}} + z\hat{\mathbf{k}}}{r} \right) \cdot (dx dz)\hat{\mathbf{j}} = \frac{Ql}{4\pi\epsilon_0 r^3} dx dz$$

Thus, the electric flux through S is

$$\begin{aligned} \Phi_E &= \oiint_S \vec{\mathbf{E}} \cdot d\vec{\mathbf{A}} = \frac{Ql}{4\pi\epsilon_0} \int_{-l}^l dx \int_{-l}^l \frac{dz}{(x^2 + l^2 + z^2)^{3/2}} = \frac{Ql}{4\pi\epsilon_0} \int_{-l}^l dx \frac{z}{(x^2 + l^2)(x^2 + l^2 + z^2)^{1/2}} \Bigg|_{-l}^l \\ &= \frac{Ql}{2\pi\epsilon_0} \int_{-l}^l \frac{l dx}{(x^2 + l^2)(x^2 + 2l^2)^{1/2}} = \frac{Q}{2\pi\epsilon_0} \tan^{-1} \left(\frac{x}{\sqrt{x^2 + 2l^2}} \right) \Bigg|_{-l}^l \\ &= \frac{Q}{2\pi\epsilon_0} \left[\tan^{-1}(1/\sqrt{3}) - \tan^{-1}(-1/\sqrt{3}) \right] = \frac{Q}{6\epsilon_0} \end{aligned}$$

where the following integrals have been used:

$$\int \frac{dx}{(x^2 + a^2)^{3/2}} = \frac{x}{a^2(x^2 + a^2)^{1/2}}$$

$$\int \frac{dx}{(x^2 + a^2)(x^2 + b^2)^{1/2}} = \frac{1}{a(b^2 - a^2)^{1/2}} \tan^{-1} \sqrt{\frac{b^2 - a^2}{a^2(x^2 + b^2)}}, \quad b^2 > a^2$$

(b) From symmetry arguments, the flux through each face must be the same. Thus, the total flux through the cube is just six times that through one face:

$$\Phi_E = 6 \left(\frac{Q}{6\epsilon_0} \right) = \frac{Q}{\epsilon_0}$$

The result shows that the electric flux Φ_E passing through a closed surface is proportional to the charge enclosed. In addition, the result further reinforces the notion that Φ_E is independent of the shape of the closed surface.

4.8.3 Gauss's Law for Gravity

What is the gravitational field inside a spherical shell of radius a and mass m ?

Solution:

Since the gravitational force is also an inverse square law, there is an equivalent Gauss's law for gravitation:

$$\Phi_g = -4\pi G m_{\text{enc}} \quad (4.8.2)$$

The only changes are that we calculate gravitational flux, the constant $1/\epsilon_0 \rightarrow -4\pi G$, and $q_{\text{enc}} \rightarrow m_{\text{enc}}$. For $r \leq a$, the mass enclosed in a Gaussian surface is zero because the mass is all on the shell. Therefore the gravitational flux on the Gaussian surface is zero. This means that the gravitational field inside the shell is zero!

4.8.4 Electric Potential of a Uniformly Charged Sphere

An insulated solid sphere of radius a has a uniform charge density ρ . Compute the electric potential everywhere.

Solution:

Using Gauss's law, we showed in Example 4.4 that the electric field due to the charge distribution is

$$\vec{\mathbf{E}} = \begin{cases} \frac{Q}{4\pi\epsilon_0 r^2} \hat{\mathbf{r}}, & r > a \\ \frac{Qr}{4\pi\epsilon_0 a^3} \hat{\mathbf{r}}, & r < a \end{cases} \quad (4.8.3)$$

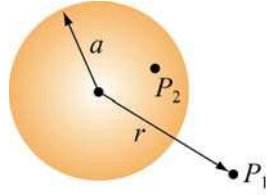

Figure 4.8.6

The electric potential at P_1 (indicated in Figure 4.8.6) outside the sphere is

$$V_1(r) - V(\infty) = -\int_{\infty}^r \frac{Q}{4\pi\epsilon_0 r'^2} dr' = \frac{1}{4\pi\epsilon_0} \frac{Q}{r} = k_e \frac{Q}{r} \quad (4.8.4)$$

On the other hand, the electric potential at P_2 inside the sphere is given by

$$\begin{aligned} V_2(r) - V(\infty) &= -\int_{\infty}^a dr E(r > a) - \int_a^r E(r < a) = -\int_{\infty}^a dr \frac{Q}{4\pi\epsilon_0 r^2} - \int_a^r dr' \frac{Qr'}{4\pi\epsilon_0 a^3} \\ &= \frac{1}{4\pi\epsilon_0} \frac{Q}{a} - \frac{1}{4\pi\epsilon_0} \frac{Q}{a^3} \frac{1}{2} (r^2 - a^2) = \frac{1}{8\pi\epsilon_0} \frac{Q}{a} \left(3 - \frac{r^2}{a^2} \right) \\ &= k_e \frac{Q}{2a} \left(3 - \frac{r^2}{a^2} \right) \end{aligned} \quad (4.8.5)$$

A plot of electric potential as a function of r is given in Figure 4.8.7:

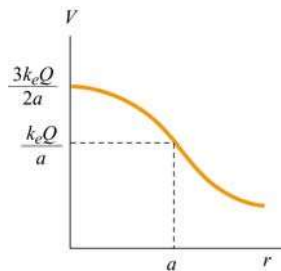

Figure 4.8.7 Electric potential due to a uniformly charged sphere as a function of r .

4.9 Conceptual Questions

1. If the electric field in some region of space is zero, does it imply that there is no electric charge in that region?
2. Consider the electric field due to a non-conducting infinite plane having a uniform charge density. Why is the electric field independent of the distance from the plane? Explain in terms of the spacing of the electric field lines.
3. If we place a point charge inside a hollow sealed conducting pipe, describe the electric field outside the pipe.
4. Consider two isolated spherical conductors each having net charge $Q > 0$. The spheres have radii a and b , where $b > a$. Which sphere has the higher potential?

4.10 Additional Problems

4.10.1 Non-Conducting Solid Sphere with a Cavity

A sphere of radius $2R$ is made of a non-conducting material that has a uniform volume charge density ρ . (Assume that the material does not affect the electric field.) A spherical cavity of radius R is then carved out from the sphere, as shown in the figure below. Compute the electric field within the cavity.

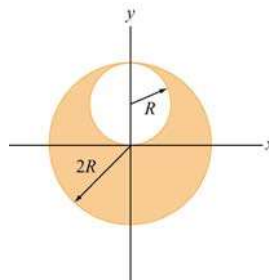

Figure 4.10.1 Non-conducting solid sphere with a cavity

4.10.2 P-N Junction

When two slabs of N-type and P-type semiconductors are put in contact, the relative affinities of the materials cause electrons to migrate out of the N-type material across the junction to the P-type material. This leaves behind a volume in the N-type material that is positively charged and creates a negatively charged volume in the P-type material.

Let us model this as two infinite slabs of charge, both of thickness a with the junction lying on the plane $z = 0$. The N-type material lies in the range $0 < z < a$ and has uniform

charge density $+\rho_0$. The adjacent P-type material lies in the range $-a < z < 0$ and has uniform charge density $-\rho_0$. Thus:

$$\rho(x, y, z) = \rho(z) = \begin{cases} +\rho_0 & 0 < z < a \\ -\rho_0 & -a < z < 0 \\ 0 & |z| > a \end{cases}$$

- (a) Find the electric field everywhere.
- (b) Find the potential difference between the points P_1 and P_2 . The point P_1 is located on a plane parallel to the slab a distance $z_1 > a$ from the center of the slab. The point P_2 is located on plane parallel to the slab a distance $z_2 < -a$ from the center of the slab.

4.10.3 Sphere with Non-Uniform Charge Distribution

A sphere made of insulating material of radius R has a charge density $\rho = ar$ where a is a constant. Let r be the distance from the center of the sphere.

- (a) Find the electric field everywhere, both inside and outside the sphere.
- (b) Find the electric potential everywhere, both inside and outside the sphere. Be sure to indicate where you have chosen your zero potential.
- (c) How much energy does it take to assemble this configuration of charge?
- (d) What is the electric potential difference between the center of the cylinder and a distance r inside the cylinder? Be sure to indicate where you have chosen your zero potential.

4.10.4 Thin Slab

Let some charge be uniformly distributed throughout the volume of a large planar slab of plastic of thickness d . The charge density is ρ . The mid-plane of the slab is the y - z plane.

- (a) What is the electric field at a distance x from the mid-plane when $|x| < d/2$?
- (b) What is the electric field at a distance x from the mid-plane when $|x| > d/2$?
[Hint: put part of your Gaussian surface where the electric field is zero.]

4.10.5 Electric Potential Energy of a Solid Sphere

Calculate the electric potential energy of a solid sphere of radius R filled with charge of uniform density ρ . Express your answer in terms of Q , the total charge on the sphere.

4.10.6 Calculating Electric Field from Electrical Potential

Figure 4.10.2 shows the variation of an electric potential V with distance z . The potential V does not depend on x or y . The potential V in the region $-1\text{ m} < z < 1\text{ m}$ is given in Volts by the expression $V(z) = 15 - 5z^2$. Outside of this region, the electric potential varies linearly with z , as indicated in the graph.

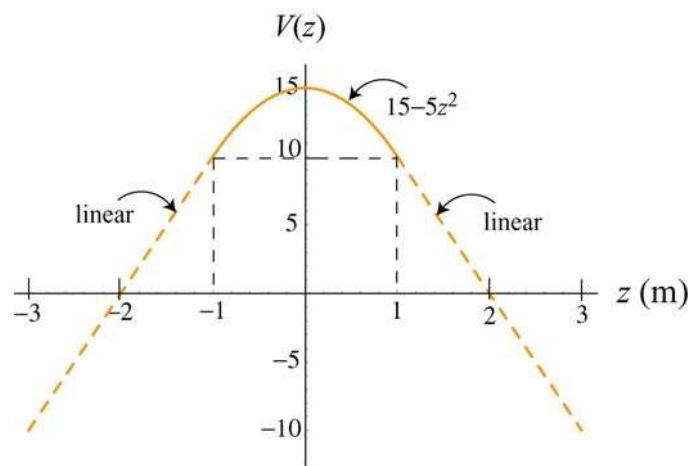

Figure 4.10.2

- Find an equation for the z -component of the electric field, E_z , in the region $-1\text{ m} < z < 1\text{ m}$.
- What is E_z in the region $z > 1\text{ m}$? Be careful to indicate the sign of E_z .
- What is E_z in the region $z < -1\text{ m}$? Be careful to indicate the sign of E_z .
- This potential is due a slab of charge with constant charge per unit volume ρ_0 . Where is this slab of charge located (give the z -coordinates that bound the slab)? What is the charge density ρ_0 of the slab in C/m^3 ? Be sure to give clearly both the sign and magnitude of ρ_0 .

Chapter 5

Capacitance and Dielectrics

5.1 Introduction.....	2
5.2 Calculation of Capacitance	3
Example 5.1: Parallel-Plate Capacitor	3
Interactive Simulation 5.1: Parallel-Plate Capacitor	5
Example 5.2: Cylindrical Capacitor.....	5
Example 5.3: Spherical Capacitor.....	7
5.3 Capacitors in Electric Circuits	8
5.3.1 Parallel Connection.....	9
5.3.2 Series Connection	10
Example 5.4: Equivalent Capacitance	11
5.4 Storing Energy in a Capacitor.....	12
5.4.1 Energy Density of the Electric Field.....	13
Interactive Simulation 5.2: Charge Placed between Capacitor Plates.....	13
Example 5.5: Electric Energy Density of Dry Air.....	14
Example 5.6: Energy Stored in a Spherical Shell	14
5.5 Dielectrics	15
5.5.1 Polarization	17
5.5.2 Dielectrics without Battery	20
5.5.3 Dielectrics with Battery	21
5.5.4 Gauss's Law for Dielectrics.....	22
Example 5.7: Capacitance with Dielectrics	24
5.6 Creating Electric Fields	25
Animation 5.1: Creating an Electric Dipole	25
Animation 5.2: Creating and Destroying Electric Energy.....	27
5.7 Summary	28
5.8 Appendix: Electric Fields Hold Atoms Together	29
5.8.1 Ionic and van der Waals Forces	30
Interactive Simulation 5.3: Collection of Charges in Two Dimensions.....	31
Interactive Simulation 5.4: Collection of Charges in Three Dimensions.....	33
Interactive Simulation 5.5: Collection of Dipoles in Two Dimensions	33
Interactive Simulation 5.6: Charged Particle Trap.....	34
Interactive Simulation 5.6: Lattice 3D	35
Interactive Simulation 5.7: 2D Electrostatic Suspension Bridge	35
Interactive Simulation 5.8: 3D Electrostatic Suspension Bridge	36
5.9 Problem-Solving Strategy: Calculating Capacitance.....	36

5.10 Solved Problems	38
5.10.1 Equivalent Capacitance.....	38
5.10.2 Capacitor Filled with Two Different Dielectrics.....	39
5.10.3 Capacitor with Dielectrics	39
5.10.4 Capacitor Connected to a Spring.....	41
5.11 Conceptual Questions	41
5.12 Additional Problems	42
5.12.1 Capacitors in Series and in Parallel	42
5.12.2 Capacitors and Dielectrics	42
5.12.3 Gauss's Law in the Presence of a Dielectric.....	43
5.12.4 Gauss's Law and Dielectrics.....	43
5.12.5 A Capacitor with a Dielectric	44
5.12.6 Force on the Plates of a Capacitor	44
5.12.7 Energy Density in a Capacitor with a Dielectric	45

Capacitance and Dielectrics

5.1 Introduction

A capacitor is a device which stores electric charge. Capacitors vary in shape and size, but the basic configuration is two conductors carrying equal but opposite charges (Figure 5.1.1). Capacitors have many important applications in electronics. Some examples include storing electric potential energy, delaying voltage changes when coupled with resistors, filtering out unwanted frequency signals, forming resonant circuits and making frequency-dependent and independent voltage dividers when combined with resistors. Some of these applications will be discussed in latter chapters.

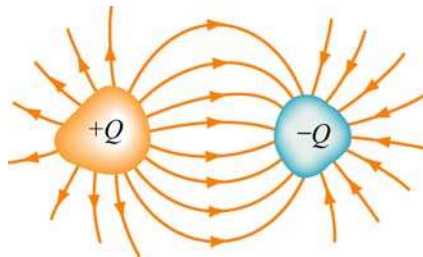

Figure 5.1.1 Basic configuration of a capacitor.

In the *uncharged* state, the charge on either one of the conductors in the capacitor is zero. During the charging process, a charge Q is moved from one conductor to the other one, giving one conductor a charge $+Q$, and the other one a charge $-Q$. A potential difference ΔV is created, with the positively charged conductor at a higher potential than the negatively charged conductor. Note that whether charged or uncharged, the net charge on the capacitor as a whole is zero.

The simplest example of a capacitor consists of two conducting plates of area A , which are parallel to each other, and separated by a distance d , as shown in Figure 5.1.2.

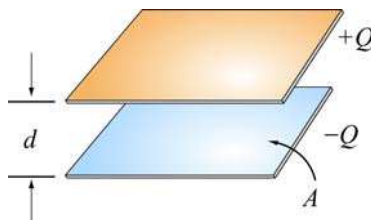

Figure 5.1.2 A parallel-plate capacitor

Experiments show that the amount of charge Q stored in a capacitor is linearly proportional to ΔV , the electric potential difference between the plates. Thus, we may write

$$Q = C |\Delta V| \quad (5.1.1)$$

where C is a positive proportionality constant called *capacitance*. Physically, capacitance is a measure of the capacity of storing electric charge for a given potential difference ΔV . The SI unit of capacitance is the *farad* (F) :

$$1 \text{ F} = 1 \text{ farad} = 1 \text{ coulomb/volt} = 1 \text{ C/V}$$

A typical capacitance is in the picofarad ($1 \text{ pF} = 10^{-12} \text{ F}$) to millifarad range, ($1 \text{ mF} = 10^{-3} \text{ F} = 1000 \mu\text{F}$; $1 \mu\text{F} = 10^{-6} \text{ F}$).

Figure 5.1.3(a) shows the symbol which is used to represent capacitors in circuits. For a polarized fixed capacitor which has a definite polarity, Figure 5.1.3(b) is sometimes used.

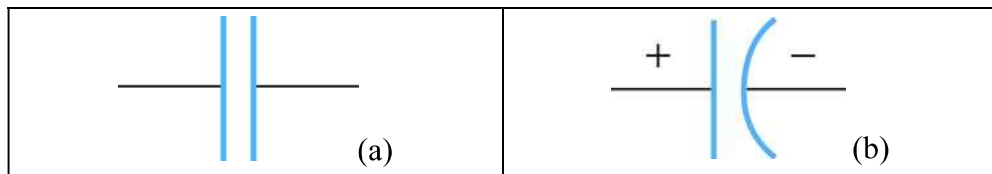

Figure 5.1.3 Capacitor symbols.

5.2 Calculation of Capacitance

Let's see how capacitance can be computed in systems with simple geometry.

Example 5.1: Parallel-Plate Capacitor

Consider two metallic plates of equal area A separated by a distance d , as shown in Figure 5.2.1 below. The top plate carries a charge $+Q$ while the bottom plate carries a charge $-Q$. The charging of the plates can be accomplished by means of a battery which produces a potential difference. Find the capacitance of the system.

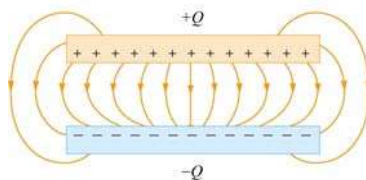

Figure 5.2.1 The electric field between the plates of a parallel-plate capacitor

Solution:

To find the capacitance C , we first need to know the electric field between the plates. A real capacitor is finite in size. Thus, the electric field lines at the edge of the plates are not straight lines, and the field is not contained entirely between the plates. This is known as

edge effects, and the non-uniform fields near the edge are called the *fringing fields*. In Figure 5.2.1 the field lines are drawn by taking into consideration edge effects. However, in what follows, we shall ignore such effects and assume an idealized situation, where field lines between the plates are straight lines.

In the limit where the plates are infinitely large, the system has planar symmetry and we can calculate the electric field everywhere using Gauss's law given in Eq. (4.2.5):

$$\oiint_S \vec{\mathbf{E}} \cdot d\vec{\mathbf{A}} = \frac{q_{\text{enc}}}{\epsilon_0}$$

By choosing a Gaussian “pillbox” with cap area A' to enclose the charge on the positive plate (see Figure 5.2.2), the electric field in the region between the plates is

$$EA' = \frac{q_{\text{enc}}}{\epsilon_0} = \frac{\sigma A'}{\epsilon_0} \Rightarrow E = \frac{\sigma}{\epsilon_0} \quad (5.2.1)$$

The same result has also been obtained in Section 4.8.1 using superposition principle.

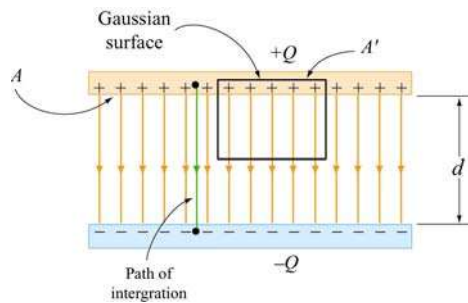

Figure 5.2.2 Gaussian surface for calculating the electric field between the plates.

The potential difference between the plates is

$$\Delta V = V_- - V_+ = -\int_+^- \vec{\mathbf{E}} \cdot d\vec{\mathbf{s}} = -Ed \quad (5.2.2)$$

where we have taken the path of integration to be a straight line from the positive plate to the negative plate following the field lines (Figure 5.2.2). Since the electric field lines are always directed from higher potential to lower potential, $V_- < V_+$. However, in computing the capacitance C , the relevant quantity is the magnitude of the potential difference:

$$|\Delta V| = Ed \quad (5.2.3)$$

and its sign is immaterial. From the definition of capacitance, we have

$$C = \frac{Q}{|\Delta V|} = \frac{\epsilon_0 A}{d} \quad (\text{parallel plate}) \quad (5.2.4)$$

Note that C depends only on the geometric factors A and d . The capacitance C increases linearly with the area A since for a given potential difference ΔV , a bigger plate can hold more charge. On the other hand, C is inversely proportional to d , the distance of separation because the smaller the value of d , the smaller the potential difference $|\Delta V|$ for a fixed Q .

Interactive Simulation 5.1: Parallel-Plate Capacitor

This simulation shown in Figure 5.2.3 illustrates the interaction of charged particles inside the two plates of a capacitor.

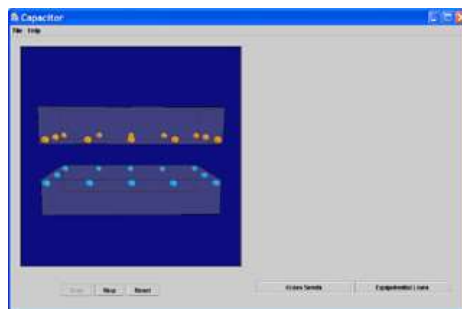

Figure 5.2.3 Charged particles interacting inside the two plates of a capacitor.

Each plate contains twelve charges interacting via Coulomb force, where one plate contains positive charges and the other contains negative charges. Because of their mutual repulsion, the particles in each plate are compelled to maximize the distance between one another, and thus spread themselves evenly around the outer edge of their enclosure. However, the particles in one plate are attracted to the particles in the other, so they attempt to minimize the distance between themselves and their oppositely charged correspondents. Thus, they distribute themselves along the surface of their bounding box closest to the other plate.

Example 5.2: Cylindrical Capacitor

Consider next a solid cylindrical conductor of radius a surrounded by a coaxial cylindrical shell of inner radius b , as shown in Figure 5.2.4. The length of both cylinders is L and we take this length to be much larger than $b - a$, the separation of the cylinders, so that edge effects can be neglected. The capacitor is charged so that the inner cylinder has charge $+Q$ while the outer shell has a charge $-Q$. What is the capacitance?

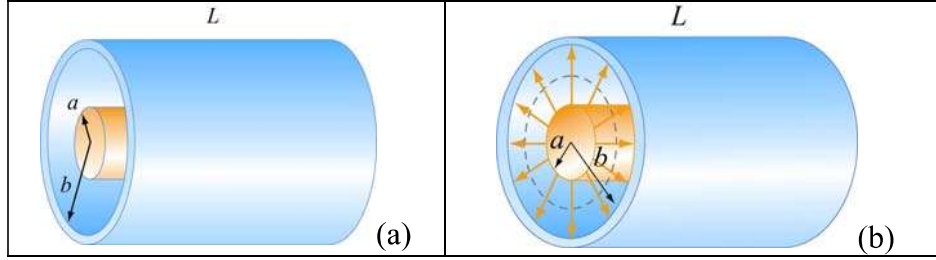

Figure 5.2.4 (a) A cylindrical capacitor. (b) End view of the capacitor. The electric field is non-vanishing only in the region $a < r < b$.

Solution:

To calculate the capacitance, we first compute the electric field everywhere. Due to the cylindrical symmetry of the system, we choose our Gaussian surface to be a coaxial cylinder with length $\ell < L$ and radius r where $a < r < b$. Using Gauss's law, we have

$$\oiint_S \vec{\mathbf{E}} \cdot d\vec{\mathbf{A}} = EA = E(2\pi r\ell) = \frac{\lambda\ell}{\epsilon_0} \Rightarrow E = \frac{\lambda}{2\pi\epsilon_0 r} \quad (5.2.5)$$

where $\lambda = Q/L$ is the charge per unit length. Notice that the electric field is non-vanishing only in the region $a < r < b$. For $r < a$, the enclosed charge is $q_{\text{enc}} = 0$ since any net charge in a conductor must reside on its surface. Similarly, for $r > b$, the enclosed charge is $q_{\text{enc}} = \lambda\ell - \lambda\ell = 0$ since the Gaussian surface encloses equal but opposite charges from both conductors.

The potential difference is given by

$$\Delta V = V_b - V_a = -\int_a^b E_r dr = -\frac{\lambda}{2\pi\epsilon_0} \int_a^b \frac{dr}{r} = -\frac{\lambda}{2\pi\epsilon_0} \ln\left(\frac{b}{a}\right) \quad (5.2.6)$$

where we have chosen the integration path to be along the direction of the electric field lines. As expected, the outer conductor with negative charge has a lower potential. This gives

$$C = \frac{Q}{|\Delta V|} = \frac{\lambda L}{\lambda \ln(b/a) / 2\pi\epsilon_0} = \frac{2\pi\epsilon_0 L}{\ln(b/a)} \quad (5.2.7)$$

Once again, we see that the capacitance C depends only on the geometrical factors, L , a and b .

Example 5.3: Spherical Capacitor

As a third example, let's consider a spherical capacitor which consists of two concentric spherical shells of radii a and b , as shown in Figure 5.2.5. The inner shell has a charge $+Q$ uniformly distributed over its surface, and the outer shell an equal but opposite charge $-Q$. What is the capacitance of this configuration?

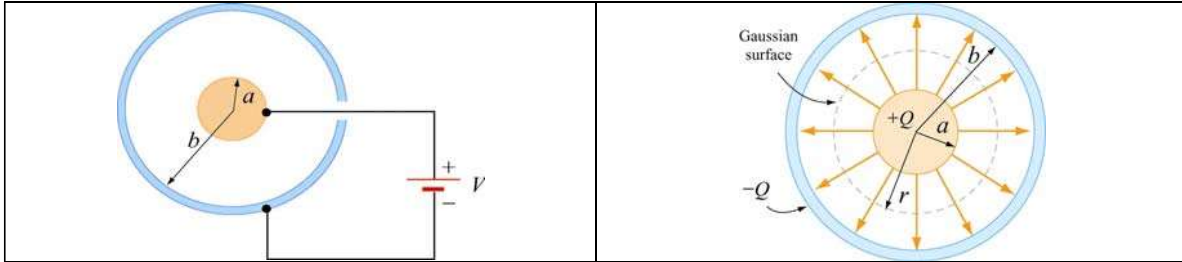

Figure 5.2.5 (a) spherical capacitor with two concentric spherical shells of radii a and b . (b) Gaussian surface for calculating the electric field.

Solution:

The electric field is non-vanishing only in the region $a < r < b$. Using Gauss's law, we obtain

$$\oiint_S \vec{\mathbf{E}} \cdot d\vec{\mathbf{A}} = E_r A = E_r (4\pi r^2) = \frac{Q}{\epsilon_0} \quad (5.2.8)$$

or

$$E_r = \frac{1}{4\pi\epsilon_0} \frac{Q}{r^2} \quad (5.2.9)$$

Therefore, the potential difference between the two conducting shells is:

$$\Delta V = V_b - V_a = -\int_a^b E_r dr = -\frac{Q}{4\pi\epsilon_0} \int_a^b \frac{dr}{r^2} = -\frac{Q}{4\pi\epsilon_0} \left(\frac{1}{a} - \frac{1}{b} \right) = -\frac{Q}{4\pi\epsilon_0} \left(\frac{b-a}{ab} \right) \quad (5.2.10)$$

which yields

$$C = \frac{Q}{|\Delta V|} = 4\pi\epsilon_0 \left(\frac{ab}{b-a} \right) \quad (5.2.11)$$

Again, the capacitance C depends only on the physical dimensions, a and b .

An "isolated" conductor (with the second conductor placed at infinity) also has a capacitance. In the limit where $b \rightarrow \infty$, the above equation becomes

$$\lim_{b \rightarrow \infty} C = \lim_{b \rightarrow \infty} 4\pi\epsilon_0 \left(\frac{ab}{b-a} \right) = \lim_{b \rightarrow \infty} 4\pi\epsilon_0 \frac{a}{\left(1 - \frac{a}{b} \right)} = 4\pi\epsilon_0 a \quad (5.2.12)$$

Thus, for a single isolated spherical conductor of radius R , the capacitance is

$$C = 4\pi\epsilon_0 R \quad (5.2.13)$$

The above expression can also be obtained by noting that a conducting sphere of radius R with a charge Q uniformly distributed over its surface has $V = Q/4\pi\epsilon_0 R$, using infinity as the reference point having zero potential, $V(\infty) = 0$. This gives

$$C = \frac{Q}{|\Delta V|} = \frac{Q}{Q/4\pi\epsilon_0 R} = 4\pi\epsilon_0 R \quad (5.2.14)$$

As expected, the capacitance of an isolated charged sphere only depends on its geometry, namely, the radius R .

5.3 Capacitors in Electric Circuits

A capacitor can be charged by connecting the plates to the terminals of a battery, which are maintained at a potential difference ΔV called the *terminal voltage*.

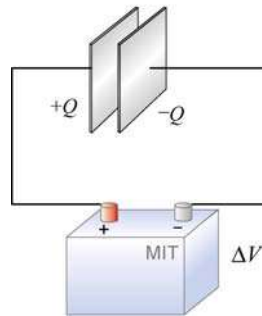

Figure 5.3.1 Charging a capacitor.

The connection results in sharing the charges between the terminals and the plates. For example, the plate that is connected to the (positive) negative terminal will acquire some (positive) negative charge. The sharing causes a momentary reduction of charges on the terminals, and a decrease in the terminal voltage. Chemical reactions are then triggered to transfer more charge from one terminal to the other to compensate for the loss of charge to the capacitor plates, and maintain the terminal voltage at its initial level. The battery could thus be thought of as a charge pump that brings a charge Q from one plate to the other.

5.3.1 Parallel Connection

Suppose we have two capacitors C_1 with charge Q_1 and C_2 with charge Q_2 that are connected in parallel, as shown in Figure 5.3.2.

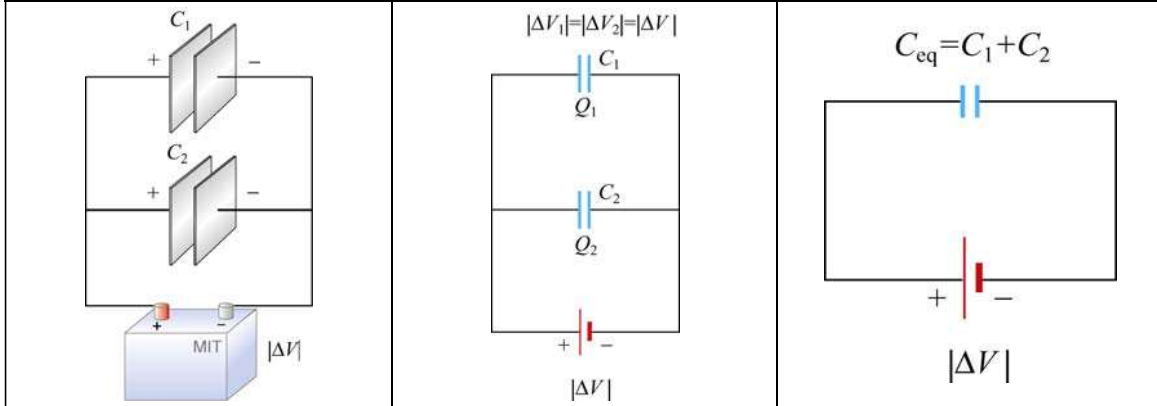

Figure 5.3.2 Capacitors in parallel and an equivalent capacitor.

The left plates of both capacitors C_1 and C_2 are connected to the positive terminal of the battery and have the same electric potential as the positive terminal. Similarly, both right plates are negatively charged and have the same potential as the negative terminal. Thus, the potential difference $|\Delta V|$ is the same across each capacitor. This gives

$$C_1 = \frac{Q_1}{|\Delta V|}, \quad C_2 = \frac{Q_2}{|\Delta V|} \quad (5.3.1)$$

These two capacitors can be replaced by a single equivalent capacitor C_{eq} with a total charge Q supplied by the battery. However, since Q is shared by the two capacitors, we must have

$$Q = Q_1 + Q_2 = C_1 |\Delta V| + C_2 |\Delta V| = (C_1 + C_2) |\Delta V| \quad (5.3.2)$$

The equivalent capacitance is then seen to be given by

$$C_{\text{eq}} = \frac{Q}{|\Delta V|} = C_1 + C_2 \quad (5.3.3)$$

Thus, capacitors that are connected in parallel add. The generalization to any number of capacitors is

$$C_{\text{eq}} = C_1 + C_2 + C_3 + \cdots + C_N = \sum_{i=1}^N C_i \quad (\text{parallel}) \quad (5.3.4)$$

5.3.2 Series Connection

Suppose two initially uncharged capacitors C_1 and C_2 are connected in series, as shown in Figure 5.3.3. A potential difference $|\Delta V|$ is then applied across both capacitors. The left plate of capacitor 1 is connected to the positive terminal of the battery and becomes positively charged with a charge $+Q$, while the right plate of capacitor 2 is connected to the negative terminal and becomes negatively charged with charge $-Q$ as electrons flow in. What about the inner plates? They were initially uncharged; now the outside plates each attract an equal and opposite charge. So the right plate of capacitor 1 will acquire a charge $-Q$ and the left plate of capacitor $+Q$.

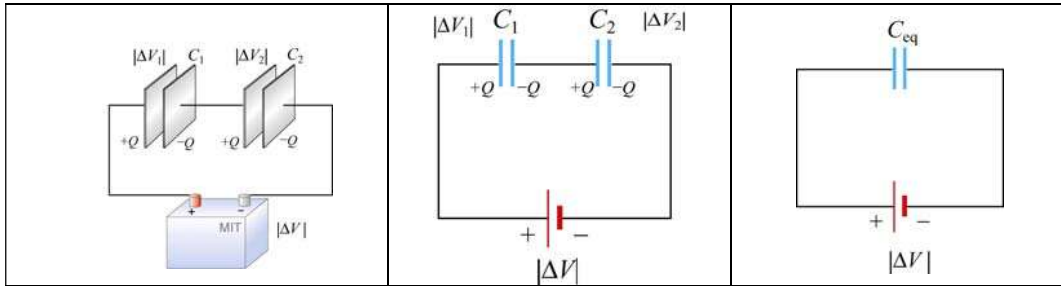

Figure 5.3.3 Capacitors in series and an equivalent capacitor

The potential differences across capacitors C_1 and C_2 are

$$|\Delta V_1| = \frac{Q}{C_1}, \quad |\Delta V_2| = \frac{Q}{C_2} \quad (5.3.5)$$

respectively. From Figure 5.3.3, we see that the total potential difference is simply the sum of the two individual potential differences:

$$|\Delta V| = |\Delta V_1| + |\Delta V_2| \quad (5.3.6)$$

In fact, the total potential difference across any number of capacitors in series connection is equal to the sum of potential differences across the individual capacitors. These two capacitors can be replaced by a single equivalent capacitor $C_{eq} = Q/|\Delta V|$. Using the fact that the potentials add in series,

$$\frac{Q}{C_{eq}} = \frac{Q}{C_1} + \frac{Q}{C_2}$$

and so the equivalent capacitance for two capacitors in series becomes

$$\frac{1}{C_{eq}} = \frac{1}{C_1} + \frac{1}{C_2} \quad (5.3.7)$$

The generalization to any number of capacitors connected in series is

$$\frac{1}{C_{\text{eq}}} = \frac{1}{C_1} + \frac{1}{C_2} + \cdots + \frac{1}{C_N} = \sum_{i=1}^N \frac{1}{C_i} \quad (\text{series}) \quad (5.3.8)$$

Example 5.4: Equivalent Capacitance

Find the equivalent capacitance for the combination of capacitors shown in Figure 5.3.4(a)

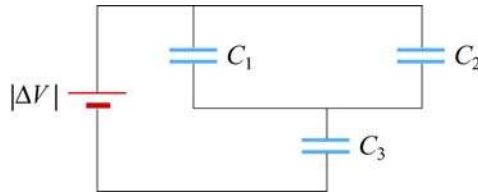

Figure 5.3.4 (a) Capacitors connected in series and in parallel

Solution:

Since C_1 and C_2 are connected in parallel, their equivalent capacitance C_{12} is given by

$$C_{12} = C_1 + C_2$$

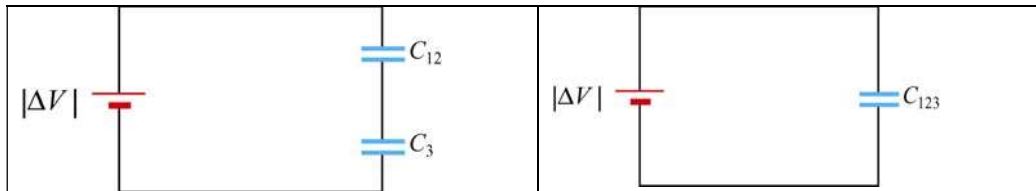

Figure 5.3.4 (b) and (c) Equivalent circuits.

Now capacitor C_{12} is in series with C_3 , as seen from Figure 5.3.4(b). So, the equivalent capacitance C_{123} is given by

$$\frac{1}{C_{123}} = \frac{1}{C_{12}} + \frac{1}{C_3}$$

or

$$C_{123} = \frac{C_{12}C_3}{C_{12} + C_3} = \frac{(C_1 + C_2)C_3}{C_1 + C_2 + C_3}$$

5.4 Storing Energy in a Capacitor

As discussed in the introduction, capacitors can be used to store electrical energy. The amount of energy stored is equal to the work done to charge it. During the charging process, the battery does work to remove charges from one plate and deposit them onto the other.

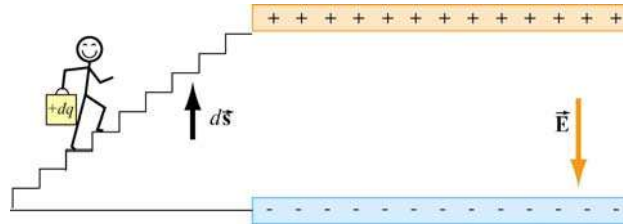

Figure 5.4.1 Work is done by an external agent in bringing $+dq$ from the negative plate and depositing the charge on the positive plate.

Let the capacitor be initially uncharged. In each plate of the capacitor, there are many negative and positive charges, but the number of negative charges balances the number of positive charges, so that there is no net charge, and therefore no electric field between the plates. We have a magic bucket and a set of stairs from the bottom plate to the top plate (Figure 5.4.1).

We start out at the bottom plate, fill our magic bucket with a charge $+dq$, carry the bucket up the stairs and dump the contents of the bucket on the top plate, charging it up positive to charge $+dq$. However, in doing so, the bottom plate is now charged to $-dq$. Having emptied the bucket of charge, we now descend the stairs, get another bucketful of charge $+dq$, go back up the stairs and dump that charge on the top plate. We then repeat this process over and over. In this way we build up charge on the capacitor, and create electric field where there was none initially.

Suppose the amount of charge on the top plate at some instant is $+q$, and the potential difference between the two plates is $|\Delta V| = q/C$. To dump another bucket of charge $+dq$ on the top plate, the amount of work done to overcome electrical repulsion is $dW = |\Delta V| dq$. If at the end of the charging process, the charge on the top plate is $+Q$, then the total amount of work done in this process is

$$W = \int_0^Q dq |\Delta V| = \int_0^Q dq \frac{q}{C} = \frac{1}{2} \frac{Q^2}{C} \quad (5.4.1)$$

This is equal to the electrical potential energy U_E of the system:

$$U_E = \frac{1}{2} \frac{Q^2}{C} = \frac{1}{2} Q |\Delta V| = \frac{1}{2} C |\Delta V|^2 \quad (5.4.2)$$

5.4.1 Energy Density of the Electric Field

One can think of the energy stored in the capacitor as being stored in the electric field itself. In the case of a parallel-plate capacitor, with $C = \epsilon_0 A / d$ and $|\Delta V| = Ed$, we have

$$U_E = \frac{1}{2} C |\Delta V|^2 = \frac{1}{2} \frac{\epsilon_0 A}{d} (Ed)^2 = \frac{1}{2} \epsilon_0 E^2 (Ad) \quad (5.4.3)$$

Since the quantity Ad represents the volume between the plates, we can define the electric energy density as

$$u_E = \frac{U_E}{\text{Volume}} = \frac{1}{2} \epsilon_0 E^2 \quad (5.4.4)$$

Note that u_E is proportional to the square of the electric field. Alternatively, one may obtain the energy stored in the capacitor from the point of view of external work. Since the plates are oppositely charged, force must be applied to maintain a constant separation between them. From Eq. (4.4.7), we see that a small patch of charge $\Delta q = \sigma(\Delta A)$ experiences an attractive force $\Delta F = \sigma^2(\Delta A) / 2\epsilon_0$. If the total area of the plate is A , then an external agent must exert a force $F_{\text{ext}} = \sigma^2 A / 2\epsilon_0$ to pull the two plates apart. Since the electric field strength in the region between the plates is given by $E = \sigma / \epsilon_0$, the external force can be rewritten as

$$F_{\text{ext}} = \frac{\epsilon_0}{2} E^2 A \quad (5.4.5)$$

Note that F_{ext} is independent of d . The total amount of work done externally to separate the plates by a distance d is then

$$W_{\text{ext}} = \int \vec{\mathbf{F}}_{\text{ext}} \cdot d\vec{\mathbf{s}} = F_{\text{ext}} d = \left(\frac{\epsilon_0 E^2 A}{2} \right) d \quad (5.4.6)$$

consistent with Eq. (5.4.3). Since the potential energy of the system is equal to the work done by the external agent, we have $u_E = W_{\text{ext}} / Ad = \epsilon_0 E^2 / 2$. In addition, we note that the expression for u_E is identical to Eq. (4.4.8) in Chapter 4. Therefore, the electric energy density u_E can also be interpreted as electrostatic pressure P .

Interactive Simulation 5.2: Charge Placed between Capacitor Plates

This applet shown in Figure 5.4.2 is a simulation of an experiment in which an aluminum sphere sitting on the bottom plate of a capacitor is lifted to the top plate by the electrostatic force generated as the capacitor is charged. We have placed a non-

conducting barrier just below the upper plate to prevent the sphere from touching it and discharging.

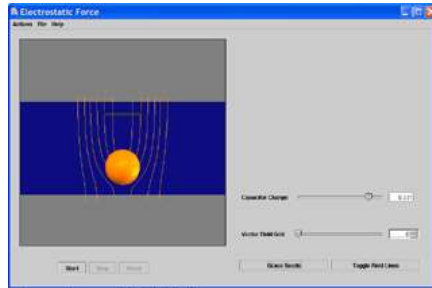

Figure 5.4.2 Electrostatic force experienced by an aluminum sphere placed between the plates of a parallel-plate capacitor.

While the sphere is in contact with the bottom plate, the charge density of the bottom of the sphere is the same as that of the lower plate. Thus, as the capacitor is charged, the charge density on the sphere increases proportional to the potential difference between the plates. In addition, energy flows in to the region between the plates as the electric field builds up. This can be seen in the motion of the electric field lines as they move from the edge to the center of the capacitor.

As the potential difference between the plates increases, the sphere feels an increasing attraction towards the top plate, indicated by the increasing tension in the field as more field lines "attach" to it. Eventually this tension is enough to overcome the downward force of gravity, and the sphere is lifted. Once separated from the lower plate, the sphere charge density no longer increases, and it feels both an attractive force towards the upper plate (whose charge is roughly opposite that of the sphere) and a repulsive force from the lower one (whose charge is roughly equal to that of the sphere). The result is a net force upwards.

Example 5.5: Electric Energy Density of Dry Air

The breakdown field strength at which dry air loses its insulating ability and allows a discharge to pass through is $E_b = 3 \times 10^6 \text{ V/m}$. At this field strength, the electric energy density is:

$$u_E = \frac{1}{2} \epsilon_0 E^2 = \frac{1}{2} (8.85 \times 10^{-12} \text{ C}^2/\text{N} \cdot \text{m}^2) (3 \times 10^6 \text{ V/m})^2 = 40 \text{ J/m}^3 \quad (5.4.7)$$

Example 5.6: Energy Stored in a Spherical Shell

Find the energy stored in a metallic spherical shell of radius a and charge Q .

Solution:

The electric field associated of a spherical shell of radius a is (Example 4.3)

$$\vec{\mathbf{E}} = \begin{cases} \frac{Q}{4\pi\epsilon_0 r^2} \hat{\mathbf{r}}, & r > a \\ \vec{\mathbf{0}}, & r < a \end{cases} \quad (5.4.8)$$

The corresponding energy density is

$$u_E = \frac{1}{2} \epsilon_0 E^2 = \frac{Q^2}{32\pi^2 \epsilon_0 r^4} \quad (5.4.9)$$

outside the sphere, and zero inside. Since the electric field is non-vanishing outside the spherical shell, we must integrate over the entire region of space from $r = a$ to $r = \infty$. In spherical coordinates, with $dV = 4\pi r^2 dr$, we have

$$U_E = \int_a^\infty \left(\frac{Q^2}{32\pi^2 \epsilon_0 r^4} \right) 4\pi r^2 dr = \frac{Q^2}{8\pi\epsilon_0} \int_a^\infty \frac{dr}{r^2} = \frac{Q^2}{8\pi\epsilon_0 a} = \frac{1}{2} QV \quad (5.4.10)$$

where $V = Q/4\pi\epsilon_0 a$ is the electric potential on the surface of the shell, with $V(\infty) = 0$. We can readily verify that the energy of the system is equal to the work done in charging the sphere. To show this, suppose at some instant the sphere has charge q and is at a potential $V = q/4\pi\epsilon_0 a$. The work required to add an additional charge dq to the system is $dW = Vdq$. Thus, the total work is

$$W = \int dW = \int Vdq = \int_0^Q dq \left(\frac{q}{4\pi\epsilon_0 a} \right) = \frac{Q^2}{8\pi\epsilon_0 a} \quad (5.4.11)$$

5.5 Dielectrics

In many capacitors there is an insulating material such as paper or plastic between the plates. Such material, called a dielectric, can be used to maintain a physical separation of the plates. Since dielectrics break down less readily than air, charge leakage can be minimized, especially when high voltage is applied.

Experimentally it was found that capacitance C increases when the space between the conductors is filled with dielectrics. To see how this happens, suppose a capacitor has a capacitance C_0 when there is no material between the plates. When a dielectric material is inserted to completely fill the space between the plates, the capacitance increases to

$$C = \kappa_e C_0 \quad (5.5.1)$$

where κ_e is called the dielectric constant. In the Table below, we show some dielectric materials with their dielectric constant. Experiments indicate that all dielectric materials have $\kappa_e > 1$. Note that every dielectric material has a characteristic dielectric strength which is the maximum value of electric field before breakdown occurs and charges begin to flow.

Material	κ_e	Dielectric strength (10^6 V/m)
Air	1.00059	3
Paper	3.7	16
Glass	4–6	9
Water	80	–

The fact that capacitance increases in the presence of a dielectric can be explained from a molecular point of view. We shall show that κ_e is a measure of the dielectric response to an external electric field. There are two types of dielectrics. The first type is polar dielectrics, which are dielectrics that have permanent electric dipole moments. An example of this type of dielectric is water.

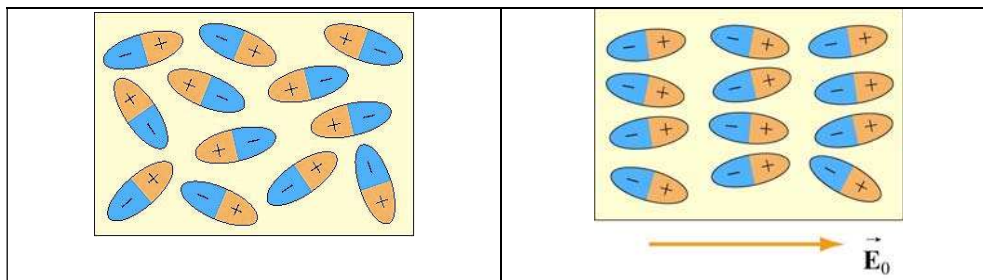

Figure 5.5.1 Orientations of polar molecules when (a) $\vec{E}_0 = \vec{0}$ and (b) $\vec{E}_0 \neq 0$.

As depicted in Figure 5.5.1, the orientation of polar molecules is random in the absence of an external field. When an external electric field \vec{E}_0 is present, a torque is set up and causes the molecules to align with \vec{E}_0 . However, the alignment is not complete due to random thermal motion. The aligned molecules then generate an electric field that is opposite to the applied field but smaller in magnitude.

The second type of dielectrics is the non-polar dielectrics, which are dielectrics that do not possess permanent electric dipole moment. Electric dipole moments can be induced by placing the materials in an externally applied electric field.

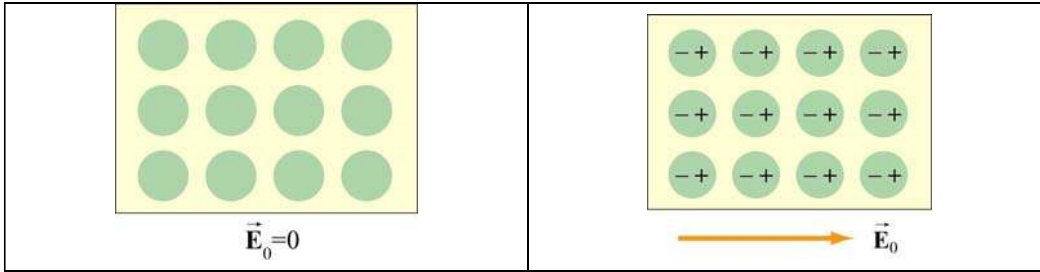

Figure 5.5.2 Orientations of non-polar molecules when (a) $\vec{E}_0 = \vec{0}$ and (b) $\vec{E}_0 \neq \vec{0}$.

Figure 5.5.2 illustrates the orientation of non-polar molecules with and without an external field \vec{E}_0 . The induced surface charges on the faces produces an electric field \vec{E}_P in the direction opposite to \vec{E}_0 , leading to $\vec{E} = \vec{E}_0 + \vec{E}_P$, with $|\vec{E}| < |\vec{E}_0|$. Below we show how the induced electric field \vec{E}_P is calculated.

5.5.1 Polarization

We have shown that dielectric materials consist of many permanent or induced electric dipoles. One of the concepts crucial to the understanding of dielectric materials is the average electric field produced by many little electric dipoles which are all aligned. Suppose we have a piece of material in the form of a cylinder with area A and height h , as shown in Figure 5.5.3, and that it consists of N electric dipoles, each with electric dipole moment \vec{p} spread uniformly throughout the volume of the cylinder.

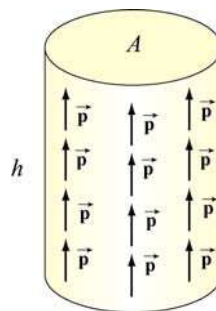

Figure 5.5.3 A cylinder with uniform dipole distribution.

We furthermore assume for the moment that all of the electric dipole moments \vec{p} are aligned with the axis of the cylinder. Since each electric dipole has its own electric field associated with it, in the absence of any external electric field, if we average over all the individual fields produced by the dipole, what is the average electric field just due to the presence of the aligned dipoles?

To answer this question, let us define the polarization vector \vec{P} to be the net electric dipole moment vector per unit volume:

$$\vec{\mathbf{P}} = \frac{1}{\text{Volume}} \sum_{i=1}^N \vec{\mathbf{p}}_i \quad (5.5.2)$$

In the case of our cylinder, where all the dipoles are perfectly aligned, the magnitude of $\vec{\mathbf{P}}$ is equal to

$$P = \frac{Np}{Ah} \quad (5.5.3)$$

and the direction of $\vec{\mathbf{P}}$ is parallel to the aligned dipoles.

Now, what is the average electric field these dipoles produce? The key to figuring this out is realizing that the situation shown in Figure 5.5.4(a) is equivalent to that shown in Figure 5.5.4(b), where all the little \pm charges associated with the electric dipoles in the interior of the cylinder are replaced with two equivalent charges, $\pm Q_p$, on the top and bottom of the cylinder, respectively.

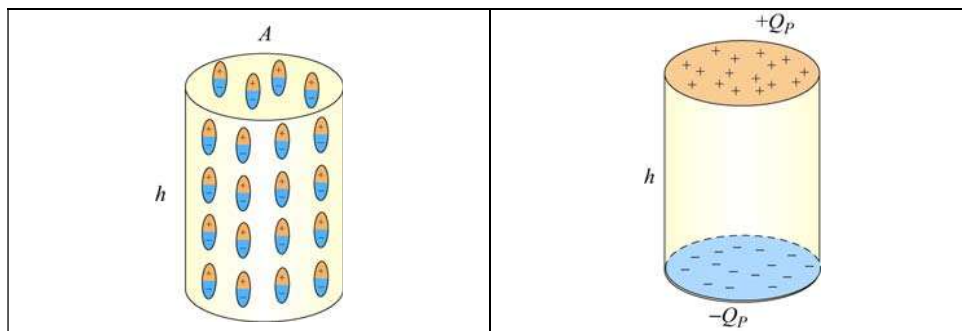

Figure 5.5.4 (a) A cylinder with uniform dipole distribution. (b) Equivalent charge distribution.

The equivalence can be seen by noting that in the interior of the cylinder, positive charge at the top of any one of the electric dipoles is *canceled* on average by the negative charge of the dipole just above it. The only place where cancellation does not take place is for electric dipoles at the top of the cylinder, since there are no adjacent dipoles further up. Thus the interior of the cylinder appears uncharged in an average sense (averaging over many dipoles), whereas the top surface of the cylinder appears to carry a net positive charge. Similarly, the bottom surface of the cylinder will appear to carry a net negative charge.

How do we find an expression for the equivalent charge Q_p in terms of quantities we know? The simplest way is to require that the electric dipole moment Q_p produces, $Q_p h$, is equal to the total electric dipole moment of all the little electric dipoles. This gives $Q_p h = Np$, or

$$Q_p = \frac{Np}{h} \quad (5.5.4)$$

To compute the electric field produced by Q_p , we note that the equivalent charge distribution resembles that of a parallel-plate capacitor, with an equivalent surface charge density σ_p that is equal to the magnitude of the polarization:

$$\sigma_p = \frac{Q_p}{A} = \frac{Np}{Ah} = P \quad (5.5.5)$$

Note that the SI units of P are $(C \cdot m)/m^3$, or C/m^2 , which is the same as the surface charge density. In general if the polarization vector makes an angle θ with $\hat{\mathbf{n}}$, the outward normal vector of the surface, the surface charge density would be

$$\sigma_p = \vec{\mathbf{P}} \cdot \hat{\mathbf{n}} = P \cos \theta \quad (5.5.6)$$

Thus, our equivalent charge system will produce an average electric field of magnitude $E_p = P / \epsilon_0$. Since the direction of this electric field is *opposite* to the direction of $\vec{\mathbf{P}}$, in vector notation, we have

$$\vec{\mathbf{E}}_p = -\vec{\mathbf{P}} / \epsilon_0 \quad (5.5.7)$$

Thus, the average electric field of all these dipoles is opposite to the direction of the dipoles themselves. It is important to realize that this is just the *average* field due to all the dipoles. If we go close to any individual dipole, we will see a very different field.

We have assumed here that all our electric dipoles are aligned. In general, if these dipoles are randomly oriented, then the polarization $\vec{\mathbf{P}}$ given in Eq. (5.5.2) will be zero, and there will be no average field due to their presence. If the dipoles have some tendency toward a preferred orientation, then $\vec{\mathbf{P}} \neq \vec{\mathbf{0}}$, leading to a non-vanishing average field $\vec{\mathbf{E}}_p$.

Let us now examine the effects of introducing dielectric material into a system. We shall first assume that the atoms or molecules comprising the dielectric material have a *permanent* electric dipole moment. If left to themselves, these permanent electric dipoles in a dielectric material never line up spontaneously, so that in the absence of any applied external electric field, $\vec{\mathbf{P}} = \vec{\mathbf{0}}$ due to the random alignment of dipoles, and the average electric field $\vec{\mathbf{E}}_p$ is zero as well. However, when we place the dielectric material in an external field $\vec{\mathbf{E}}_0$, the dipoles will experience a torque $\vec{\boldsymbol{\tau}} = \vec{\mathbf{p}} \times \vec{\mathbf{E}}_0$ that tends to align the dipole vectors $\vec{\mathbf{p}}$ with $\vec{\mathbf{E}}_0$. The effect is a net polarization $\vec{\mathbf{P}}$ parallel to $\vec{\mathbf{E}}_0$, and therefore an average electric field of the dipoles $\vec{\mathbf{E}}_p$ *anti-parallel* to $\vec{\mathbf{E}}_0$, i.e., that will tend to *reduce* the total electric field strength below $\vec{\mathbf{E}}_0$. The total electric field $\vec{\mathbf{E}}$ is the sum of these two fields:

$$\vec{\mathbf{E}} = \vec{\mathbf{E}}_0 + \vec{\mathbf{E}}_p = \vec{\mathbf{E}}_0 - \vec{\mathbf{P}} / \epsilon_0 \quad (5.5.8)$$

In most cases, the polarization $\vec{\mathbf{P}}$ is not only in the same direction as $\vec{\mathbf{E}}_0$, but also linearly proportional to $\vec{\mathbf{E}}_0$ (and hence $\vec{\mathbf{E}}$.) This is reasonable because without the external field $\vec{\mathbf{E}}_0$ there would be no alignment of dipoles and no polarization $\vec{\mathbf{P}}$. We write the linear relation between $\vec{\mathbf{P}}$ and $\vec{\mathbf{E}}$ as

$$\vec{\mathbf{P}} = \epsilon_0 \chi_e \vec{\mathbf{E}} \quad (5.5.9)$$

where χ_e is called the *electric susceptibility*. Materials they obey this relation are *linear dielectrics*. Combing Eqs. (5.5.8) and (5.5.7) gives

$$\vec{\mathbf{E}}_0 = (1 + \chi_e) \vec{\mathbf{E}} = \kappa_e \vec{\mathbf{E}} \quad (5.5.10)$$

where

$$\kappa_e = (1 + \chi_e) \quad (5.5.11)$$

is the dielectric constant. The dielectric constant κ_e is always greater than one since $\chi_e > 0$. This implies

$$E = \frac{E_0}{\kappa_e} < E_0 \quad (5.5.12)$$

Thus, we see that the effect of dielectric materials is always to decrease the electric field below what it would otherwise be.

In the case of dielectric material where there are no permanent electric dipoles, a similar effect is observed because the presence of an external field $\vec{\mathbf{E}}_0$ induces electric dipole moments in the atoms or molecules. These induced electric dipoles are parallel to $\vec{\mathbf{E}}_0$, again leading to a polarization $\vec{\mathbf{P}}$ parallel to $\vec{\mathbf{E}}_0$, and a reduction of the total electric field strength.

5.5.2 Dielectrics without Battery

As shown in Figure 5.5.5, a battery with a potential difference $|\Delta V_0|$ across its terminals is first connected to a capacitor C_0 , which holds a charge $Q_0 = C_0 |\Delta V_0|$. We then disconnect the battery, leaving $Q_0 = \text{const}$.

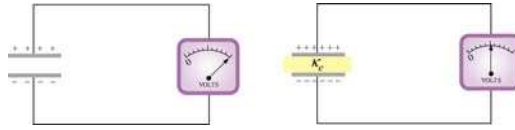

Figure 5.5.5 Inserting a dielectric material between the capacitor plates while keeping the charge Q_0 constant

If we then insert a dielectric between the plates, while keeping the charge constant, experimentally it is found that the potential difference decreases by a factor of κ_e :

$$|\Delta V| = \frac{|\Delta V_0|}{\kappa_e} \quad (5.5.13)$$

This implies that the capacitance is changed to

$$C = \frac{Q}{|\Delta V|} = \frac{Q_0}{|\Delta V_0|/\kappa_e} = \kappa_e \frac{Q_0}{|\Delta V_0|} = \kappa_e C_0 \quad (5.5.14)$$

Thus, we see that the capacitance has increased by a factor of κ_e . The electric field within the dielectric is now

$$E = \frac{|\Delta V|}{d} = \frac{|\Delta V_0|/\kappa_e}{d} = \frac{1}{\kappa_e} \left(\frac{|\Delta V_0|}{d} \right) = \frac{E_0}{\kappa_e} \quad (5.5.15)$$

We see that in the presence of a dielectric, the electric field decreases by a factor of κ_e .

5.5.3 Dielectrics with Battery

Consider a second case where a battery supplying a potential difference $|\Delta V_0|$ remains connected as the dielectric is inserted. Experimentally, it is found (first by Faraday) that the charge on the plates is increased by a factor κ_e :

$$Q = \kappa_e Q_0 \quad (5.5.16)$$

where Q_0 is the charge on the plates in the absence of any dielectric.

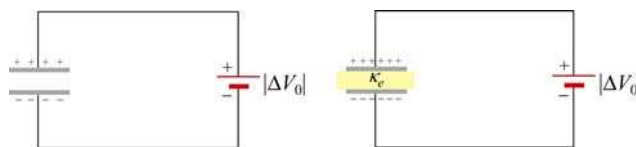

Figure 5.5.6 Inserting a dielectric material between the capacitor plates while maintaining a constant potential difference $|\Delta V_0|$.

The capacitance becomes

$$C = \frac{Q}{|\Delta V_0|} = \frac{\kappa_e Q_0}{|\Delta V_0|} = \kappa_e C_0 \quad (5.5.17)$$

which is the same as the first case where the charge Q_0 is kept constant, but now the charge has increased.

5.5.4 Gauss's Law for Dielectrics

Consider again a parallel-plate capacitor shown in Figure 5.5.7:

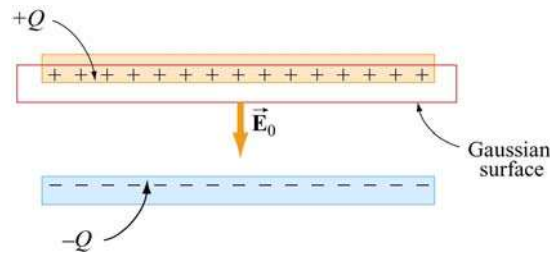

Figure 5.5.7 Gaussian surface in the absence of a dielectric.

When no dielectric is present, the electric field \vec{E}_0 in the region between the plates can be found by using Gauss's law:

$$\oiint_S \vec{E} \cdot d\vec{A} = E_0 A = \frac{Q}{\epsilon_0}, \quad \Rightarrow \quad E_0 = \frac{\sigma}{\epsilon_0}$$

We have seen that when a dielectric is inserted (Figure 5.5.8), there is an induced charge Q_p of opposite sign on the surface, and the net charge enclosed by the Gaussian surface is $Q - Q_p$.

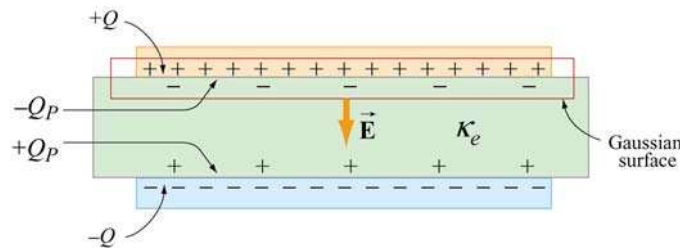

Figure 5.5.8 Gaussian surface in the presence of a dielectric.

Gauss's law becomes

$$\oiint_S \vec{\mathbf{E}} \cdot d\vec{\mathbf{A}} = EA = \frac{Q - Q_p}{\epsilon_0} \quad (5.5.18)$$

or

$$\boxed{E = \frac{Q - Q_p}{\epsilon_0 A}} \quad (5.5.19)$$

However, we have just seen that the effect of the dielectric is to weaken the original field E_0 by a factor κ_e . Therefore,

$$E = \frac{E_0}{\kappa_e} = \frac{Q}{\kappa_e \epsilon_0 A} = \frac{Q - Q_p}{\epsilon_0 A} \quad (5.5.20)$$

from which the induced charge Q_p can be obtained as

$$Q_p = Q \left(1 - \frac{1}{\kappa_e} \right) \quad (5.5.21)$$

In terms of the surface charge density, we have

$$\sigma_p = \sigma \left(1 - \frac{1}{\kappa_e} \right) \quad (5.5.22)$$

Note that in the limit $\kappa_e = 1$, $Q_p = 0$ which corresponds to the case of no dielectric material.

Substituting Eq. (5.5.21) into Eq. (5.5.18), we see that Gauss's law with dielectric can be rewritten as

$$\oiint_S \vec{\mathbf{E}} \cdot d\vec{\mathbf{A}} = \frac{Q}{\kappa_e \epsilon_0} = \frac{Q}{\epsilon} \quad (5.5.23)$$

where $\epsilon = \kappa_e \epsilon_0$ is called the *dielectric permittivity*. Alternatively, we may also write

$$\oiint_S \vec{\mathbf{D}} \cdot d\vec{\mathbf{A}} = Q \quad (5.5.24)$$

where $\vec{\mathbf{D}} = \epsilon_0 \kappa_e \vec{\mathbf{E}}$ is called the *electric displacement vector*.

Example 5.7: Capacitance with Dielectrics

A non-conducting slab of thickness t , area A and dielectric constant κ_e is inserted into the space between the plates of a parallel-plate capacitor with spacing d , charge Q and area A , as shown in Figure 5.5.9(a). The slab is not necessarily halfway between the capacitor plates. What is the capacitance of the system?

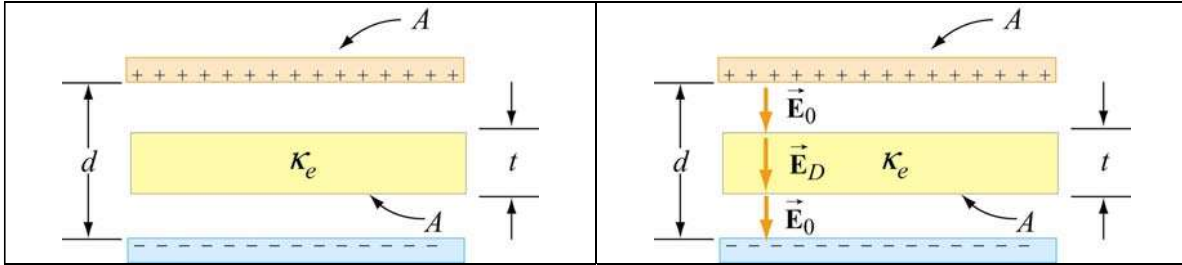

Figure 5.5.9 (a) Capacitor with a dielectric. (b) Electric field between the plates.

Solution:

To find the capacitance C , we first calculate the potential difference ΔV . We have already seen that in the absence of a dielectric, the electric field between the plates is given by $E_0 = Q/\epsilon_0 A$, and $E_D = E_0/\kappa_e$ when a dielectric of dielectric constant κ_e is present, as shown in Figure 5.5.9(b). The potential can be found by integrating the electric field along a straight line from the top to the bottom plates:

$$\begin{aligned} \Delta V &= -\int_+^- E dl = -\Delta V_0 - \Delta V_D = -E_0 (d-t) - E_D t = -\frac{Q}{A\epsilon_0} (d-t) - \frac{Q}{A\epsilon_0 \kappa_e} t \\ &= -\frac{Q}{A\epsilon_0} \left[d-t \left(1 - \frac{1}{\kappa_e} \right) \right] \end{aligned} \quad (5.5.25)$$

where $\Delta V_D = E_D t$ is the potential difference between the two faces of the dielectric. This gives

$$C = \frac{Q}{|\Delta V|} = \frac{\epsilon_0 A}{d-t \left(1 - \frac{1}{\kappa_e} \right)} \quad (5.5.26)$$

It is useful to check the following limits:

(i) As $t \rightarrow 0$, *i.e.*, the thickness of the dielectric approaches zero, we have $C = \epsilon_0 A/d = C_0$, which is the expected result for no dielectric.

(ii) As $\kappa_e \rightarrow 1$, we again have $C \rightarrow \epsilon_0 A/d = C_0$, and the situation also correspond to the case where the dielectric is absent.

(iii) In the limit where $t \rightarrow d$, the space is filled with dielectric, we have $C \rightarrow \kappa_e \epsilon_0 A / d = \kappa_e C_0$.

We also comment that the configuration is equivalent to two capacitors connected in series, as shown in Figure 5.5.10.

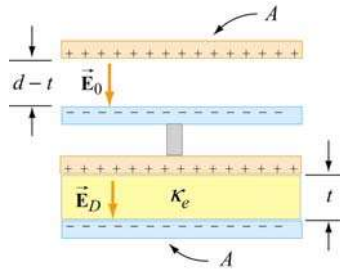

Figure 5.5.10 Equivalent configuration.

Using Eq. (5.3.8) for capacitors connected in series, the equivalent capacitance is

$$\frac{1}{C} = \frac{d-t}{\epsilon_0 A} + \frac{t}{\kappa_e \epsilon_0 A} \quad (5.5.28)$$

5.6 Creating Electric Fields

Animation 5.1: Creating an Electric Dipole

Electric fields are created by electric charge. If there is no electric charge present, and there never has been any electric charge present in the past, then there would be no electric field anywhere in space. How is electric field created and how does it come to fill up space? To answer this, consider the following scenario in which we go from the electric field being zero everywhere in space to an electric field existing everywhere in space.

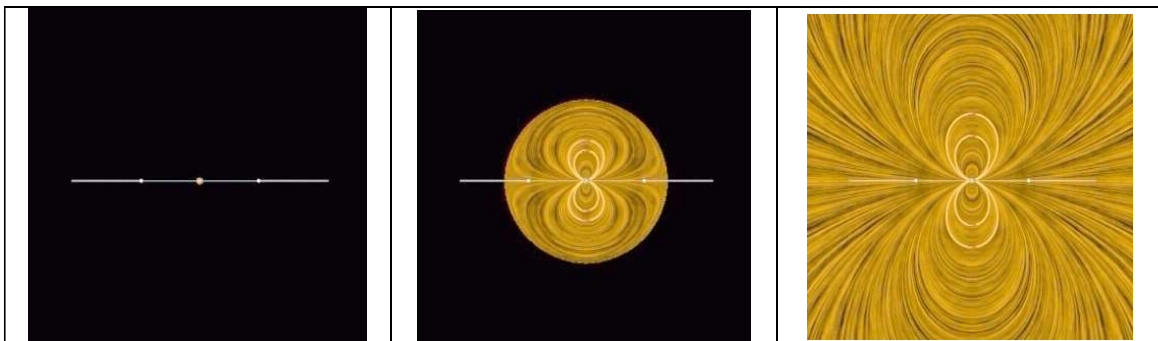

Figure 5.6.1 Creating an electric dipole. (a) Before any charge separation. (b) Just after the charges are separated. (c) A long time after the charges are separated.

Suppose we have a positive point charge sitting right on top of a negative electric charge, so that the total charge exactly cancels, and there is no electric field anywhere in space. Now let us pull these two charges apart slightly, so that they are separated by a small distance. If we allow them to sit at that distance for a long time, there will now be a charge imbalance – an electric dipole. The dipole will create an electric field.

Let us see how this creation of electric field takes place in detail. Figure 5.6.1 shows three frames of an animation of the process of separating the charges. In Figure 5.6.1(a), there is no charge separation, and the electric field is zero everywhere in space. Figure 5.6.1(b) shows what happens just after the charges are first separated. An expanding sphere of electric fields is observed. Figure 5.6.1(c) is a long time after the charges are separated (that is, they have been at a constant distance from another for a long time). An electric dipole has been created.

What does this sequence tell us? The following conclusions can be drawn:

- (1) It is electric charge that generates electric field — no charge, no field.
- (2) The electric field does not appear instantaneously in space everywhere as soon as there is unbalanced charge — the electric field propagates outward from its source at some finite speed. This speed will turn out to be the speed of light, as we shall see later.
- (3) After the charge distribution settles down and becomes stationary, so does the field configuration. The initial field pattern associated with the time dependent separation of the charge is actually a burst of “electric dipole radiation.” We return to the subject of radiation at the end of this course. Until then, we will neglect radiation fields. The field configuration left behind after a long time is just the electric dipole pattern discussed above.

We note that the external agent who pulls the charges apart has to do work to keep them separate, since they attract each other as soon as they start to separate. Therefore, the external work done is to overcome the electrostatic attraction. In addition, the work also goes into providing the energy carried off by radiation, as well as the energy needed to set up the final stationary electric field that we see in Figure 5.6.1(c).

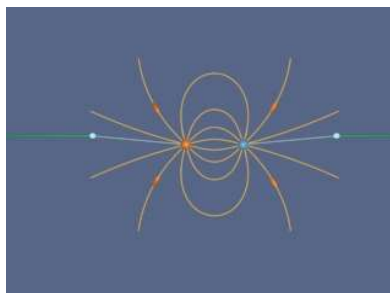

Figure 5.6.2 Creating the electric fields of two point charges by pulling apart two opposite charges initially on top of one another. We artificially terminate the field lines at a fixed distance from the charges to avoid visual confusion.

Finally, we ignore radiation and complete the process of separating our opposite point charges that we began in Figure 5.6.1. Figure 5.6.2 shows the complete sequence. When we finish and have moved the charges far apart, we see the characteristic radial field in the vicinity of a point charge.

Animation 5.2: Creating and Destroying Electric Energy

Let us look at the process of creating electric energy in a different context. We ignore energy losses due to radiation in this discussion. Figure 5.6.3 shows one frame of an animation that illustrates the following process.



Figure 5.6.3 Creating and destroying electric energy.

We start out with five negative electric charges and five positive charges, all at the same point in space. Since there is no net charge, there is no electric field. Now we move one of the positive charges at constant velocity from its initial position to a distance L away along the horizontal axis. After doing that, we move the second positive charge in the same manner to the position where the first positive charge sits. After doing that, we continue on with the rest of the positive charges in the same manner, until all the positive charges are sitting a distance L from their initial position along the horizontal axis. Figure 5.6.3 shows the field configuration during this process. We have color coded the “grass seeds” representation to represent the strength of the electric field. Very strong fields are white, very weak fields are black, and fields of intermediate strength are yellow.

Over the course of the “create” animation associated with Figure 5.6.3, the strength of the electric field grows as each positive charge is moved into place. The electric energy flows out from the path along which the charges move, and is being provided by the agent moving the charge against the electric field of the other charges. The work that this agent does to separate the charges against their electric attraction appears as energy in the electric field. We also have an animation of the opposite process linked to Figure 5.6.3. That is, we return in sequence each of the five positive charges to their original positions. At the end of this process we no longer have an electric field, because we no longer have an unbalanced electric charge.

On the other hand, over the course of the “destroy” animation associated with Figure 5.6.3, the strength of the electric field decreases as each positive charge is returned to its original position. The energy flows from the field back to the path along which the

charges move, and is now being provided *to* the agent moving the charge at constant speed along the electric field of the other charges. The energy provided to that agent as we destroy the electric field is exactly the amount of energy that the agent put into creating the electric field in the first place, neglecting radiative losses (such losses are small if we move the charges at speeds small compared to the speed of light). This is a totally reversible process if we neglect such losses. That is, the amount of energy the agent puts into creating the electric field is exactly returned to that agent as the field is destroyed.

There is one final point to be made. Whenever electromagnetic energy is being created, an electric charge is moving (or being moved) against an electric field ($q \vec{v} \cdot \vec{E} < 0$). Whenever electromagnetic energy is being destroyed, an electric charge is moving (or being moved) along an electric field ($q \vec{v} \cdot \vec{E} > 0$). When we return to the creation and destruction of magnetic energy, we will find this rule holds there as well.

5.7 Summary

- A **capacitor** is a device that stores electric charge and potential energy. The **capacitance** C of a capacitor is the ratio of the charge stored on the capacitor plates to the the potential difference between them:

$$C = \frac{Q}{|\Delta V|}$$

System	Capacitance
Isolated charged sphere of radius R	$C = 4\pi\epsilon_0 R$
Parallel-plate capacitor of plate area A and plate separation d	$C = \epsilon_0 \frac{A}{d}$
Cylindrical capacitor of length L , inner radius a and outer radius b	$C = \frac{2\pi\epsilon_0 L}{\ln(b/a)}$
Spherical capacitor with inner radius a and outer radius b	$C = 4\pi\epsilon_0 \frac{ab}{(b-a)}$

- The equivalent capacitance of capacitors connected in parallel and in series are

$$C_{\text{eq}} = C_1 + C_2 + C_3 + \dots \quad (\text{parallel})$$

$$\frac{1}{C_{\text{eq}}} = \frac{1}{C_1} + \frac{1}{C_2} + \frac{1}{C_3} + \dots \quad (\text{series})$$

- The work done in charging a capacitor to a charge Q is

$$U = \frac{Q^2}{2C} = \frac{1}{2}Q|\Delta V| = \frac{1}{2}C|\Delta V|^2$$

This is equal to the amount of energy stored in the capacitor.

- The electric energy can also be thought of as stored in the electric field \vec{E} . The **energy density** (energy per unit volume) is

$$u_E = \frac{1}{2}\epsilon_0 E^2$$

The energy density u_E is equal to the **electrostatic pressure** on a surface.

- When a dielectric material with **dielectric constant** κ_e is inserted into a capacitor, the capacitance increases by a factor κ_e :

$$C = \kappa_e C_0$$

- The **polarization** vector \vec{P} is the magnetic dipole moment per unit volume:

$$\vec{P} = \frac{1}{V} \sum_{i=1}^N \vec{p}_i$$

The induced electric field due to polarization is

$$\vec{E}_p = -\vec{P} / \epsilon_0$$

- In the presence of a dielectric with dielectric constant κ_e , the electric field becomes

$$\vec{E} = \vec{E}_0 + \vec{E}_p = \vec{E}_0 / \kappa_e$$

where \vec{E}_0 is the electric field without dielectric.

5.8 Appendix: Electric Fields Hold Atoms Together

In this Appendix, we illustrate how electric fields are responsible for holding atoms together.

“...As our mental eye penetrates into smaller and smaller distances and shorter and shorter times, we find nature behaving so entirely differently from what we observe in visible and palpable bodies of our surroundings that no model shaped after our large-scale experiences can ever be "true". A completely satisfactory model of this type is not only practically inaccessible, but not even thinkable. Or, to be precise, we can, of course, think of it, but however we think it, it is wrong.”

Erwin Schroedinger

5.8.1 Ionic and van der Waals Forces

Electromagnetic forces provide the “glue” that holds atoms together—that is, that keep electrons near protons and bind atoms together in solids. We present here a brief and very idealized model of how that happens from a semi-classical point of view.

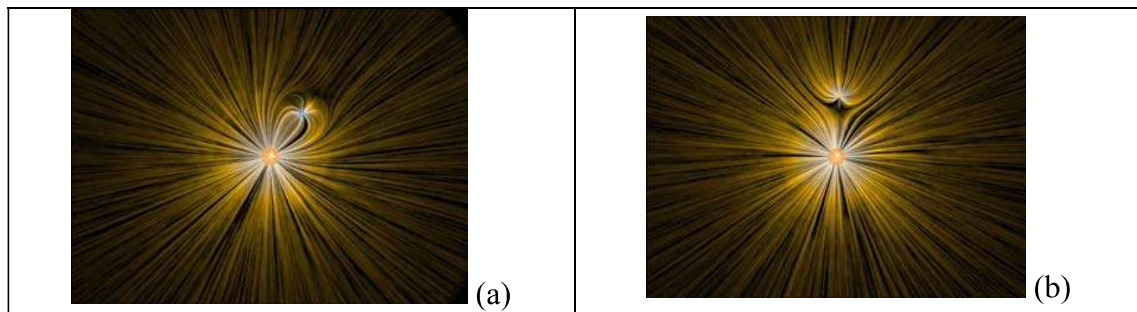

Figure 5.8.1 (a) A negative charge and (b) a positive charge moves past a massive positive particle at the origin and is deflected from its path by the stresses transmitted by the electric fields surrounding the charges.

Figure 5.8.1(a) illustrates the examples of the stresses transmitted by fields, as we have seen before. In Figure 5.8.1(a) we have a negative charge moving past a massive positive charge and being deflected toward that charge due to the attraction that the two charges feel. This attraction is mediated by the stresses transmitted by the electromagnetic field, and the simple interpretation of the interaction shown in Figure 5.8.1(b) is that the attraction is primarily due to a tension transmitted by the electric fields surrounding the charges.

In Figure 5.8.1(b) we have a positive charge moving past a massive positive charge and being deflected away from that charge due to the repulsion that the two charges feel. This repulsion is mediated by the stresses transmitted by the electromagnetic field, as we have discussed above, and the simple interpretation of the interaction shown in Figure 5.8.1(b) is that the repulsion is primarily due to a pressure transmitted by the electric fields surrounding the charges.

Consider the interaction of four charges of equal mass shown in Figure 5.8.2. Two of the charges are positively charged and two of the charges are negatively charged, and all have the same magnitude of charge. The particles interact via the Coulomb force.

We also introduce a quantum-mechanical “Pauli” force, which is always repulsive and becomes very important at small distances, but is negligible at large distances. The critical distance at which this repulsive force begins to dominate is about the radius of the spheres shown in Figure 5.8.2. This Pauli force is quantum mechanical in origin, and keeps the charges from collapsing into a point (i.e., it keeps a negative particle and a positive particle from sitting exactly on top of one another).

Additionally, the motion of the particles is damped by a term proportional to their velocity, allowing them to "settle down" into stable (or meta-stable) states.

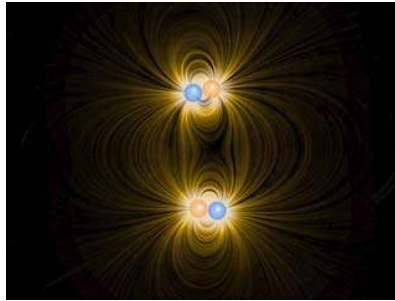

Figure 5.8.2 Four charges interacting via the Coulomb force, a repulsive Pauli force at close distances, with dynamic damping.

When these charges are allowed to evolve from the initial state, the first thing that happens (very quickly) is that the charges pair off into dipoles. This is a rapid process because the Coulomb attraction between unbalanced charges is very large. This process is called "ionic binding", and is responsible for the inter-atomic forces in ordinary table salt, NaCl. After the dipoles form, there is still an interaction between neighboring dipoles, but this is a much weaker interaction because the electric field of the dipoles falls off much faster than that of a single charge. This is because the net charge of the dipole is zero. When two opposite charges are close to one another, their electric fields “almost” cancel each other out.

Although in principle the dipole-dipole interaction can be either repulsive or attractive, in practice there is a torque that rotates the dipoles so that the dipole-dipole force is attractive. After a long time, this dipole-dipole attraction brings the two dipoles together in a bound state. The force of attraction between two dipoles is termed a “van der Waals” force, and it is responsible for intermolecular forces that bind some substances together into a solid.

Interactive Simulation 5.3: Collection of Charges in Two Dimensions

Figure 5.8.3 is an interactive two-dimensional ShockWave display that shows the same dynamical situation as in Figure 5.8.2 except that we have included a number of positive and negative charges, and we have eliminated the representation of the field so that we

can interact with this simulation in real time. We start the charges at rest in random positions in space, and then let them evolve according to the forces that act on them (electrostatic attraction/repulsion, Pauli repulsion at very short distances, and a dynamic drag term proportional to velocity). The particles will eventually end up in a configuration in which the net force on any given particle is essentially zero. As we saw in the animation in Figure 5.8.3, generally the individual particles first pair off into dipoles and then slowly combine into larger structures. Rings and straight lines are the most common configurations, but by clicking and dragging particles around, the user can coax them into more complex meta-stable formations.

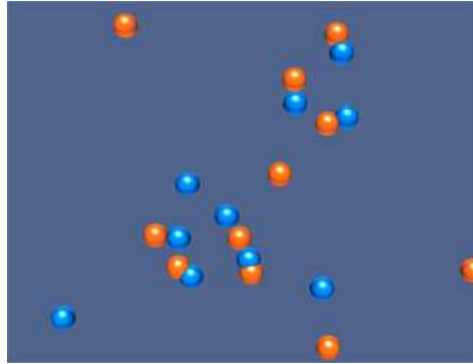

Figure 5.8.3 A two dimensional interactive simulation of a collection of positive and negative charges affected by the Coulomb force and the Pauli repulsive force, with dynamic damping.

In particular, try this sequence of actions with the display. Start it and wait until the simulation has evolved to the point where you have a line of particles made up of seven or eight particles. Left click on one of the end charges of this line and drag it with the mouse. If you do this slowly enough, the entire line of charges will follow along with the charge you are virtually “touching”. When you move that charge, you are putting “energy” into the charge you have selected on one end of the line. This “energy” is going into moving that charge, but it is also being supplied to the rest of the charges via their electromagnetic fields. The “energy” that the charge on the opposite end of the line receives a little while after you start moving the first charge is delivered to it entirely by energy flowing through space in the electromagnetic field, from the site where you create that energy.

This is a microcosm of how you interact with the world. A physical object lying on the floor in front is held together by electrostatic forces. Quantum mechanics keeps it from collapsing; electrostatic forces keep it from flying apart. When you reach down and pick that object up by one end, energy is transferred from where you grasp the object to the rest of it by energy flow in the electromagnetic field. When you raise it above the floor, the “tail end” of the object never “touches” the point where you grasp it. All of the energy provided to the “tail end” of the object to move it upward against gravity is provided by energy flow via electromagnetic fields, through the complicated web of electromagnetic fields that hold the object together.

Interactive Simulation 5.4: Collection of Charges in Three Dimensions

Figure 5.8.4 is an interactive three-dimensional ShockWave display that shows the same dynamical situation as in Figure 5.8.3 except that we are looking at the scene in three dimensions. This display can be rotated to view from different angles by right-clicking and dragging in the display. We start the charges at rest in random positions in space, and then let them evolve according to the forces that act on them (electrostatic attraction/repulsion, Pauli repulsion at very short distances, and a dynamic drag term proportional to velocity). Here the configurations are more complex because of the availability of the third dimension. In particular, one can hit the “w” key to toggle a force that pushes the charges together on and off. Toggling this force *on* and letting the charges settle down in a “clump”, and then toggling it *off* to let them expand, allows the construction of complicated three dimension structures that are “meta-stable”. An example of one of these is given in Figure 5.8.4.

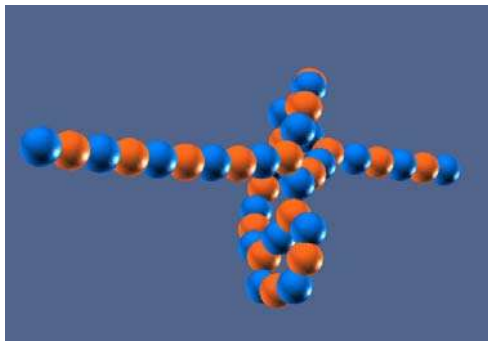

Figure 5.8.4 An three-dimensional interactive simulation of a collection of positive and negative charges affected by the Coulomb force and the Pauli repulsive force, with dynamic damping.

Interactive Simulation 5.5: Collection of Dipoles in Two Dimensions

Figure 5.8.5 shows an interactive ShockWave simulation that allows one to interact in two dimensions with a group of electric dipoles.

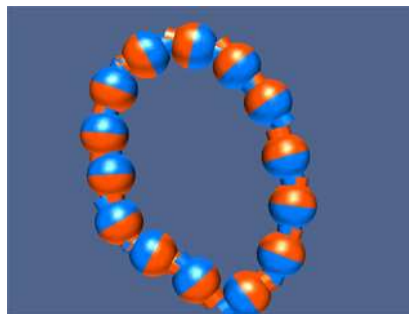

Figure 5.8.5 An interactive simulation of a collection of electric dipoles affected by the Coulomb force and the Pauli repulsive force, with dynamic damping.

The dipoles are created with random positions and orientations, with all the electric dipole vectors in the plane of the display. As we noted above, although in principle the dipole-dipole interaction can be either repulsive or attractive, in practice there is a torque that rotates the dipoles so that the dipole-dipole force is attractive. In the ShockWave simulation we see this behavior—that is, the dipoles orient themselves so as to attract, and then the attraction gathers them together into bound structures.

Interactive Simulation 5.6: Charged Particle Trap

Figure 5.8.6 shows an interactive simulation of a charged particle trap.

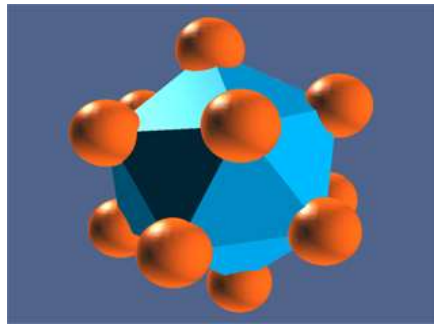

Figure 5.8.6 An interactive simulation of a particle trap.

Particles interact as before, but in addition each particle feels a force that pushes them toward the origin, regardless of the sign of their charge. That “trapping” force increases linearly with distance from the origin. The charges initially are randomly distributed in space, but as time increases the dynamic damping “cools” the particles and they “crystallize” into a number of highly symmetric structures, depending on the number of particles. This mimics the highly ordered structures that we see in nature (e.g., snowflakes).

Exercise:

Start the simulation. The simulation initially introduces 12 positive charges in random positions (you can of course add more particles of either sign, but for the moment we deal with only the initial 12). About half the time, the 12 charges will settle down into an equilibrium in which there is a charge in the center of a sphere on which the other 11 charges are arranged. The other half of the time all 12 particles will be arranged on the surface of a sphere, with no charge in the middle. Whichever arrangement you initially find, see if you can move one of the particles into position so that you get to the other stable configuration. To move a charge, push shift and left click, and use the arrow buttons to move it up, down, left, and right. You may have to select several different charges in turn to find one that you can move into the center, if your initial equilibrium does not have a center charge.

Here is another exercise. Put an additional 8 positive charges into the display (by pressing “p” eight times) for a total of 20 charges. By moving charges around as above, you can get two charges in inside a spherical distribution of the other 18. Is this the lowest number of charges for which you can get equilibrium with two charges inside? That is, can you do this with 18 charges? Note that if you push the “s” key you will get generate a surface based on the positions of the charges in the sphere, which will make its symmetries more apparent.

Interactive Simulation 5.6: Lattice 3D

Lattice 3D, shown in Figure 5.8.7, simulates the interaction of charged particles in three dimensions. The particles interact via the classical Coulomb force, as well as the repulsive quantum-mechanical Pauli force, which acts at close distances (accounting for the “collisions” between them). Additionally, the motion of the particles is damped by a term proportional to their velocity, allowing them to “settle down” into stable (or meta-stable) states.

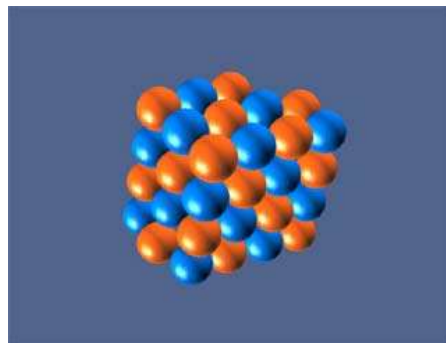

Figure 5.8.7 *Lattice 3D* simulating the interaction of charged particles in three dimensions.

In this simulation, the proportionality of the Coulomb and Pauli forces has been adjusted to allow for lattice formation, as one might see in a crystal. The “preferred” stable state is a rectangular (cubic) lattice, although other formations are possible depending on the number of particles and their initial positions.

Selecting a particle and pressing “f” will toggle field lines illustrating the local field around that particle. Performance varies depending on the number of particles / field lines in the simulation.

Interactive Simulation 5.7: 2D Electrostatic Suspension Bridge

To connect electrostatic forces to one more example of the real world, Figure 5.8.8 is a simulation of a 2D “electrostatic suspension bridge.” The bridge is created by attaching a series of positive and negatively charged particles to two fixed endpoints, and adding a downward gravitational force. The tension in the “bridge” is supplied simply by the

Coulomb interaction of its constituent parts and the Pauli force keeps the charges from collapsing in on each other. Initially, the bridge only sags slightly under the weight of gravity. However the user can introduce additional “neutral” particles (by pressing “o”) to stress the bridge more, until the electrostatic bonds “break” under the stress and the bridge collapses.

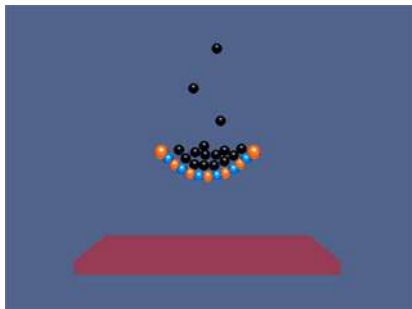

Figure 5.8.8 A ShockWave simulation of a 2D electrostatic suspension bridge.

Interactive Simulation 5.8: 3D Electrostatic Suspension Bridge

In the simulation shown in Figure 5.8.9, a 3D “electrostatic suspension bridge” is created by attaching a lattice of positive and negatively charged particles between four fixed corners, and adding a downward gravitational force. The tension in the “bridge” is supplied simply by the Coulomb interaction of its constituent parts and the Pauli force keeping them from collapsing in on each other. Initially, the bridge only sags slightly under the weight of gravity, but what would happen to it under a rain of massive neutral particles? Press “o” to find out.

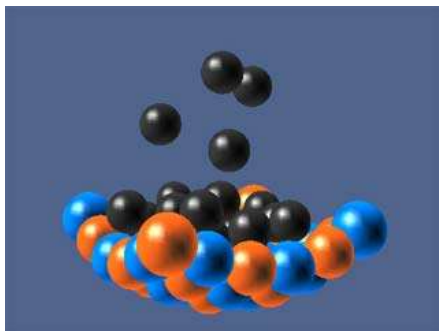

Figure 5.8.9 A ShockWave simulation of a 3D electrostatic suspension bridge.

5.9 Problem-Solving Strategy: Calculating Capacitance

In this chapter, we have seen how capacitance C can be calculated for various systems. The procedure is summarized below:

- (1) Identify the direction of the electric field using symmetry.
- (2) Calculate the electric field everywhere.
- (3) Compute the electric potential difference ΔV .
- (4) Calculate the capacitance C using $C = Q / |\Delta V|$.

In the Table below, we illustrate how the above steps are used to calculate the capacitance of a parallel-plate capacitor, cylindrical capacitor and a spherical capacitor.

Capacitors	Parallel-plate	Cylindrical	Spherical
Figure			
(1) Identify the direction of the electric field using symmetry			
(2) Calculate electric field everywhere	$\oiint_S \vec{E} \cdot d\vec{A} = EA = \frac{Q}{\epsilon_0}$ $E = \frac{Q}{A\epsilon_0} = \frac{\sigma}{\epsilon_0}$	$\oiint_S \vec{E} \cdot d\vec{A} = E(2\pi r l) = \frac{Q}{\epsilon_0}$ $E = \frac{\lambda}{2\pi\epsilon_0 r}$	$\oiint_S \vec{E} \cdot d\vec{A} = E_r (4\pi r^2) = \frac{Q}{\epsilon_0}$ $E_r = \frac{1}{4\pi\epsilon_0} \frac{Q}{r^2}$
(3) Compute the electric potential difference ΔV	$\Delta V = V_- - V_+ = -\int_+^- \vec{E} \cdot d\vec{s}$ $= -Ed$	$\Delta V = V_b - V_a = -\int_a^b E_r dr$ $= -\frac{\lambda}{2\pi\epsilon_0} \ln\left(\frac{b}{a}\right)$	$\Delta V = V_b - V_a = -\int_a^b E_r dr$ $= -\frac{Q}{4\pi\epsilon_0} \left(\frac{b-a}{ab}\right)$

(4) Calculate C using $C = Q/ \Delta V $	$C = \frac{\epsilon_0 A}{d}$	$C = \frac{2\pi\epsilon_0 l}{\ln(b/a)}$	$C = 4\pi\epsilon_0 \left(\frac{ab}{b-a} \right)$
--------------------------------------------	------------------------------	-----------------------------------------	----------------------------------------------------

5.10 Solved Problems

5.10.1 Equivalent Capacitance

Consider the configuration shown in Figure 5.10.1. Find the equivalent capacitance, assuming that all the capacitors have the same capacitance C .

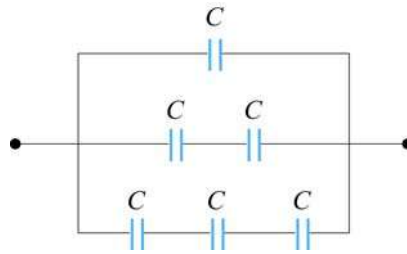

Figure 5.10.1 Combination of Capacitors

Solution:

For capacitors that are connected in series, the equivalent capacitance is

$$\frac{1}{C_{\text{eq}}} = \frac{1}{C_1} + \frac{1}{C_2} + \dots = \sum_i \frac{1}{C_i} \quad (\text{series})$$

On the other hand, for capacitors that are connected in parallel, the equivalent capacitance is

$$C_{\text{eq}} = C_1 + C_2 + \dots = \sum_i C_i \quad (\text{parallel})$$

Using the above formula for series connection, the equivalent configuration is shown in Figure 5.10.2.

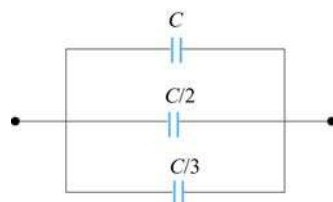

Figure 5.10.2

Now we have three capacitors connected in parallel. The equivalent capacitance is given by

$$C_{\text{eq}} = C \left(1 + \frac{1}{2} + \frac{1}{3} \right) = \frac{11}{6} C$$

5.10.2 Capacitor Filled with Two Different Dielectrics

Two dielectrics with dielectric constants κ_1 and κ_2 each fill half the space between the plates of a parallel-plate capacitor as shown in Figure 5.10.3.

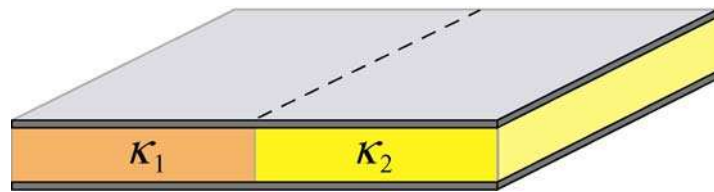

Figure 5.10.3 Capacitor filled with two different dielectrics.

Each plate has an area A and the plates are separated by a distance d . Compute the capacitance of the system.

Solution:

Since the potential difference on each half of the capacitor is the same, we may treat the system as being composed of two capacitors connected in parallel. Thus, the capacitance of the system is

$$C = C_1 + C_2$$

With

$$C_i = \frac{\kappa_i \epsilon_0 (A/2)}{d}, \quad i = 1, 2$$

we obtain

$$C = \frac{\kappa_1 \epsilon_0 (A/2)}{d} + \frac{\kappa_2 \epsilon_0 (A/2)}{d} = \frac{\epsilon_0 A}{2d} (\kappa_1 + \kappa_2)$$

5.10.3 Capacitor with Dielectrics

Consider a conducting spherical shell with an inner radius a and outer radius c . Let the space between two surfaces be filled with two different dielectric materials so that the

dielectric constant is κ_1 between a and b , and κ_2 between b and c , as shown in Figure 5.10.4. Determine the capacitance of this system.

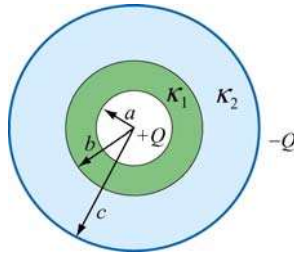

Figure 5.10.4 Spherical capacitor filled with dielectrics.

Solution:

The system can be treated as two capacitors connected in series, since the total potential difference across the capacitors is the sum of potential differences across individual capacitors. The equivalent capacitance for a spherical capacitor of inner radius r_1 and outer radius r_2 filled with dielectric with dielectric constant κ_e is given by

$$C = 4\pi\epsilon_0\kappa_e \left(\frac{r_1 r_2}{r_2 - r_1} \right)$$

Thus, the equivalent capacitance of this system is

$$\frac{1}{C} = \frac{1}{\frac{4\pi\epsilon_0\kappa_1 ab}{(b-a)}} + \frac{1}{\frac{4\pi\epsilon_0\kappa_2 bc}{(c-b)}} = \frac{\kappa_2 c(b-a) + \kappa_1 a(c-b)}{4\pi\epsilon_0\kappa_1\kappa_2 abc}$$

or

$$C = \frac{4\pi\epsilon_0\kappa_1\kappa_2 abc}{\kappa_2 c(b-a) + \kappa_1 a(c-b)}$$

It is instructive to check the limit where $\kappa_1, \kappa_2 \rightarrow 1$. In this case, the above expression reduces to

$$C = \frac{4\pi\epsilon_0 abc}{c(b-a) + a(c-b)} = \frac{4\pi\epsilon_0 abc}{b(c-a)} = \frac{4\pi\epsilon_0 ac}{(c-a)}$$

which agrees with Eq. (5.2.11) for a spherical capacitor of inner radius a and outer radius c .

5.10.4 Capacitor Connected to a Spring

Consider an air-filled parallel-plate capacitor with one plate connected to a spring having a force constant k , and another plate held fixed. The system rests on a table top as shown in Figure 5.10.5.

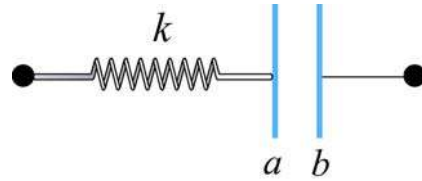

Figure 5.10.5 Capacitor connected to a spring.

If the charges placed on plates a and b are $+Q$ and $-Q$, respectively, how much does the spring expand?

Solution:

The spring force \vec{F}_s acting on plate a is given by

$$\vec{F}_s = -kx \hat{i}$$

Similarly, the electrostatic force \vec{F}_e due to the electric field created by plate b is

$$\vec{F}_e = QE \hat{i} = Q \left(\frac{\sigma}{2\epsilon_0} \right) \hat{i} = \frac{Q^2}{2A\epsilon_0} \hat{i}$$

where A is the area of the plate. Notice that charges on plate a cannot exert a force on itself, as required by Newton's third law. Thus, only the electric field due to plate b is considered. At equilibrium the two forces cancel and we have

$$kx = Q \left(\frac{Q}{2A\epsilon_0} \right)$$

which gives

$$x = \frac{Q^2}{2kA\epsilon_0}$$

5.11 Conceptual Questions

1. The charges on the plates of a parallel-plate capacitor are of opposite sign, and they attract each other. To increase the plate separation, is the external work done positive or negative? What happens to the external work done in this process?

2. How does the stored energy change if the potential difference across a capacitor is tripled?
3. Does the presence of a dielectric increase or decrease the maximum operating voltage of a capacitor? Explain.
4. If a dielectric-filled capacitor is cooled down, what happens to its capacitance?

5.12 Additional Problems

5.12.1 Capacitors in Series and in Parallel

A 12-Volt battery charges the four capacitors shown in Figure 5.12.1.

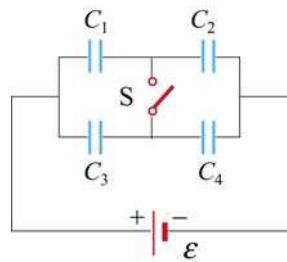

Figure 5.12.1

Let $C_1 = 1 \mu\text{F}$, $C_2 = 2 \mu\text{F}$, $C_3 = 3 \mu\text{F}$, and $C_4 = 4 \mu\text{F}$.

- (a) What is the equivalent capacitance of the group C_1 and C_2 if switch S is open (as shown)?
- (b) What is the charge on *each* of the four capacitors if switch S is open?
- (c) What is the charge on each of the four capacitors if switch S is closed?

5.12.2 Capacitors and Dielectrics

- (a) A parallel-plate capacitor of area A and spacing d is filled with three dielectrics as shown in Figure 5.12.2. Each occupies $1/3$ of the volume. What is the capacitance of this system? [*Hint*: Consider an equivalent system to be three parallel capacitors, and justify this assumption.] Show that you obtain the proper limits as the dielectric constants approach unity, $\kappa_i \rightarrow 1$.]

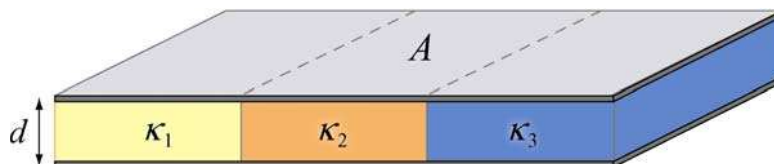

Figure 5.12.2

(b) This capacitor is now filled as shown in Figure 5.12.3. What is its capacitance? Use Gauss's law to find the field in each dielectric, and then calculate ΔV across the entire capacitor. Again, check your answer as the dielectric constants approach unity, $\kappa_i \rightarrow 1$. Could you have assumed that this system is equivalent to three capacitors in series?



Figure 5.12.3

5.12.3 Gauss's Law in the Presence of a Dielectric

A solid conducting sphere with a radius R_1 carries a free charge Q and is surrounded by a concentric dielectric spherical shell with an outer radius R_2 and a dielectric constant κ_e . This system is isolated from other conductors and resides in air ($\kappa_e \approx 1$), as shown in Figure 5.12.4.

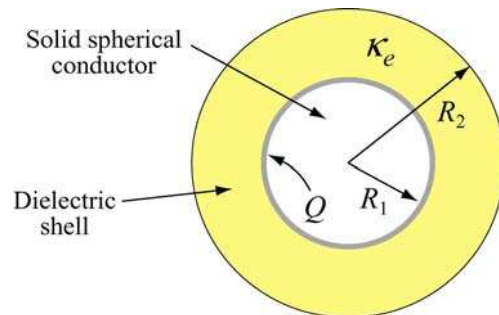

Figure 5.12.4

(a) Determine the displacement vector \vec{D} everywhere, *i.e.* its magnitude and direction in the regions $r < R_1$, $R_1 < r < R_2$ and $r > R_2$.

(b) Determine the electric field \vec{E} everywhere.

5.12.4 Gauss's Law and Dielectrics

A cylindrical shell of dielectric material has inner radius a and outer radius b , as shown in Figure 5.12.5.

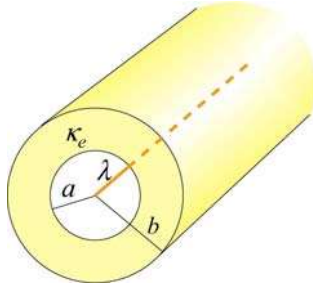

Figure 5.12.5

The material has a dielectric constant $\kappa_e = 10$. At the center of the shell there is a line charge running parallel to the axis of the cylindrical shell, with free charge per unit length λ .

- Find the electric field for: $r < a$, $a < r < b$ and $r > b$.
- What is the induced surface charge per unit length on the inner surface of the spherical shell? [Ans: $-9\lambda/10$.]
- What is the induced surface charge per unit length on the outer surface of the spherical shell? [Ans: $+9\lambda/10$.]

5.12.5 A Capacitor with a Dielectric

A parallel plate capacitor has a capacitance of 112 pF, a plate area of 96.5 cm^2 , and a mica dielectric ($\kappa_e = 5.40$). At a 55 V potential difference, calculate

- the electric field strength in the mica; [Ans: 13.4 kV/m.]
- the magnitude of the free charge on the plates; [Ans: 6.16 nC.]
- the magnitude of the induced surface charge; [Ans: 5.02 nC.]
- the magnitude of the polarization \vec{P} [Ans: 520 nC/m².]

5.12.6 Force on the Plates of a Capacitor

The plates of a parallel-plate capacitor have area A and carry total charge $\pm Q$ (see Figure 5.12.6). We would like to show that these plates *attract* each other with a force given by $F = Q^2/(2\epsilon_0 A)$.

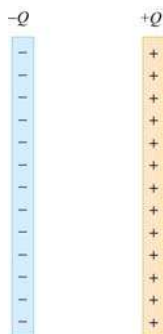

Figure 5.12.6

- (a) Calculate the total force on the left plate due to the electric field of the right plate, using Coulomb's Law. Ignore fringing fields.
- (b) If you pull the plates apart, against their attraction, you are doing work and *that work goes directly into creating additional electrostatic energy*. Calculate the force necessary to increase the plate separation from x to $x+dx$ by equating the work you do, $\vec{F} \cdot d\vec{x}$, to the increase in electrostatic energy, assuming that the electric energy density is $\epsilon_0 E^2/2$, and that the charge Q remains constant.
- (c) Using this expression for the force, show that the force per unit area (the *electrostatic stress*) acting on either capacitor plate is given by $\epsilon_0 E^2/2$. This result is true for a conductor of any shape with an electric field \vec{E} at its surface.
- (d) Atmospheric pressure is 14.7 lb/in^2 , or $101,341 \text{ N/m}^2$. How large would E have to be to produce this force per unit area? [Ans: 151 MV/m . Note that Van de Graff accelerators can reach fields of 100 MV/m maximum before breakdown, so that electrostatic stresses are on the same order as atmospheric pressures in this extreme situation, but not much greater].

5.12.7 Energy Density in a Capacitor with a Dielectric

Consider the case in which a dielectric material with dielectric constant κ_e completely fills the space between the plates of a parallel-plate capacitor. Show that the energy density of the field between the plates is $u_E = \vec{E} \cdot \vec{D}/2$ by the following procedure:

- (a) Write the expression $u_E = \vec{E} \cdot \vec{D}/2$ as a function of \mathbf{E} and κ_e (i.e. eliminate \vec{D}).
- (b) Given the electric field and potential of such a capacitor with free charge q on it (problem 4-1a above), calculate the work done to charge up the capacitor from $q = 0$ to $q = Q$, the final charge.
- (c) Find the energy density u_E .

Chapter 6

Current and Resistance

6.1 Electric Current.....	1
6.1.1 Current Density.....	1
6.2 Ohm's Law	3
6.3 Electrical Energy and Power.....	6
6.4 Summary.....	7
6.5 Solved Problems	8
6.5.1 Resistivity of a Cable.....	8
6.5.2 Charge at a Junction.....	9
6.5.3 Drift Velocity.....	10
6.5.4 Resistance of a Truncated Cone.....	11
6.5.5 Resistance of a Hollow Cylinder	12
6.6 Conceptual Questions	13
6.7 Additional Problems	13
6.7.1 Current and Current Density.....	13
6.7.2 Power Loss and Ohm's Law.....	13
6.7.3 Resistance of a Cone.....	14
6.7.4 Current Density and Drift Speed.....	14
6.7.5 Current Sheet	15
6.7.6 Resistance and Resistivity.....	15
6.7.7 Power, Current, and Voltage.....	16
6.7.8 Charge Accumulation at the Interface	16

Current and Resistance

6.1 Electric Current

Electric currents are flows of electric charge. Suppose a collection of charges is moving perpendicular to a surface of area A , as shown in Figure 6.1.1.

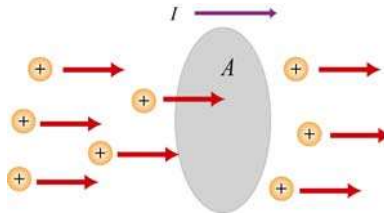

Figure 6.1.1 Charges moving through a cross section.

The electric current is defined to be the rate at which charges flow across any cross-sectional area. If an amount of charge ΔQ passes through a surface in a time interval Δt , then the average current I_{avg} is given by

$$I_{\text{avg}} = \frac{\Delta Q}{\Delta t} \quad (6.1.1)$$

The SI unit of current is the ampere (A), with $1 \text{ A} = 1 \text{ coulomb/sec}$. Common currents range from mega-amperes in lightning to nano-amperes in your nerves. In the limit $\Delta t \rightarrow 0$, the instantaneous current I may be defined as

$$I = \frac{dQ}{dt} \quad (6.1.2)$$

Since flow has a direction, we have implicitly introduced a convention that the direction of current corresponds to the direction in which positive charges are flowing. The flowing charges inside wires are negatively charged electrons that move in the opposite direction of the current. Electric currents flow in conductors: solids (metals, semiconductors), liquids (electrolytes, ionized) and gases (ionized), but the flow is impeded in non-conductors or insulators.

6.1.1 Current Density

To relate current, a macroscopic quantity, to the microscopic motion of the charges, let's examine a conductor of cross-sectional area A , as shown in Figure 6.1.2.

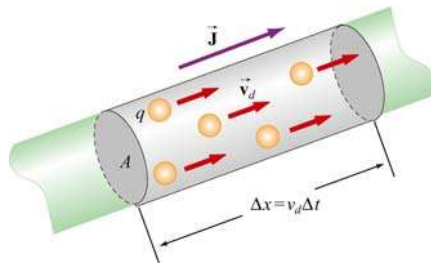

Figure 6.1.2 A microscopic picture of current flowing in a conductor.

Let the total current through a surface be written as

$$I = \iint \vec{\mathbf{J}} \cdot d\vec{\mathbf{A}} \quad (6.1.3)$$

where $\vec{\mathbf{J}}$ is the current density (the SI unit of current density are A/m^2). If q is the charge of each carrier, and n is the number of charge carriers per unit volume, the total amount of charge in this section is then $\Delta Q = q(nA\Delta x)$. Suppose that the charge carriers move with a speed v_d ; then the displacement in a time interval Δt will be $\Delta x = v_d\Delta t$, which implies

$$I_{\text{avg}} = \frac{\Delta Q}{\Delta t} = nqv_d A \quad (6.1.4)$$

The speed v_d at which the charge carriers are moving is known as the *drift speed*. Physically, v_d is the average speed of the charge carriers inside a conductor when an external electric field is applied. Actually an electron inside the conductor does not travel in a straight line; instead, its path is rather erratic, as shown in Figure 6.1.3.

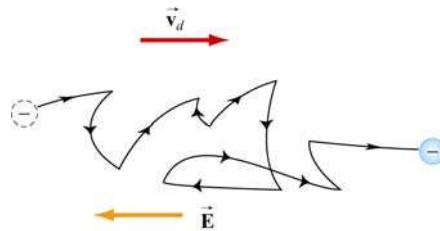

Figure 6.1.3 Motion of an electron in a conductor.

From the above equations, the current density $\vec{\mathbf{J}}$ can be written as

$$\vec{\mathbf{J}} = nq\vec{v}_d \quad (6.1.5)$$

Thus, we see that $\vec{\mathbf{J}}$ and \vec{v}_d point in the same direction for positive charge carriers, in opposite directions for negative charge carriers.

To find the drift velocity of the electrons, we first note that an electron in the conductor experiences an electric force $\vec{\mathbf{F}}_e = -e\vec{\mathbf{E}}$ which gives an acceleration

$$\vec{\mathbf{a}} = \frac{\vec{\mathbf{F}}_e}{m_e} = -\frac{e\vec{\mathbf{E}}}{m_e} \quad (6.1.6)$$

Let the velocity of a given electron immediate after a collision be $\vec{\mathbf{v}}_i$. The velocity of the electron immediately before the next collision is then given by

$$\vec{\mathbf{v}}_f = \vec{\mathbf{v}}_i + \vec{\mathbf{a}}t = \vec{\mathbf{v}}_i - \frac{e\vec{\mathbf{E}}}{m_e}t \quad (6.1.7)$$

where t is the time traveled. The average of $\vec{\mathbf{v}}_f$ over all time intervals is

$$\langle \vec{\mathbf{v}}_f \rangle = \langle \vec{\mathbf{v}}_i \rangle - \frac{e\vec{\mathbf{E}}}{m_e} \langle t \rangle \quad (6.1.8)$$

which is equal to the drift velocity $\vec{\mathbf{v}}_d$. Since in the absence of electric field, the velocity of the electron is completely random, it follows that $\langle \vec{\mathbf{v}}_i \rangle = 0$. If $\tau = \langle t \rangle$ is the average characteristic time between successive collisions (the *mean free time*), we have

$$\vec{\mathbf{v}}_d = \langle \vec{\mathbf{v}}_f \rangle = -\frac{e\vec{\mathbf{E}}}{m_e}\tau \quad (6.1.9)$$

The current density in Eq. (6.1.5) becomes

$$\vec{\mathbf{J}} = -ne\vec{\mathbf{v}}_d = -ne\left(-\frac{e\vec{\mathbf{E}}}{m_e}\tau\right) = \frac{ne^2\tau}{m_e}\vec{\mathbf{E}} \quad (6.1.10)$$

Note that $\vec{\mathbf{J}}$ and $\vec{\mathbf{E}}$ will be in the same direction for either negative or positive charge carriers.

6.2 Ohm's Law

In many materials, the current density is linearly dependent on the external electric field $\vec{\mathbf{E}}$. Their relation is usually expressed as

$$\vec{\mathbf{J}} = \sigma\vec{\mathbf{E}} \quad (6.2.1)$$

where σ is called the *conductivity* of the material. The above equation is known as the (microscopic) Ohm's law. A material that obeys this relation is said to be ohmic; otherwise, the material is non-ohmic.

Comparing Eq. (6.2.1) with Eq. (6.1.10), we see that the conductivity can be expressed as

$$\sigma = \frac{ne^2\tau}{m_e} \quad (6.2.2)$$

To obtain a more useful form of Ohm's law for practical applications, consider a segment of straight wire of length l and cross-sectional area A , as shown in Figure 6.2.1.

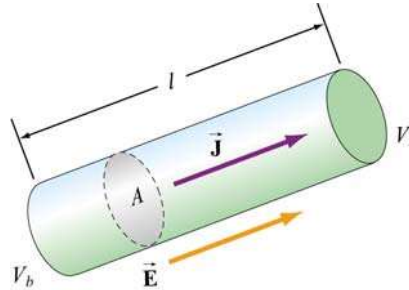

Figure 6.2.1 A uniform conductor of length l and potential difference $\Delta V = V_b - V_a$.

Suppose a potential difference $\Delta V = V_b - V_a$ is applied between the ends of the wire, creating an electric field \vec{E} and a current I . Assuming \vec{E} to be uniform, we then have

$$\Delta V = V_b - V_a = -\int_a^b \vec{E} \cdot d\vec{s} = El \quad (6.2.3)$$

The current density can then be written as

$$J = \sigma E = \sigma \left(\frac{\Delta V}{l} \right) \quad (6.2.4)$$

With $J = I/A$, the potential difference becomes

$$\Delta V = \frac{l}{\sigma} J = \left(\frac{l}{\sigma A} \right) I = RI \quad (6.2.5)$$

where

$$R = \frac{\Delta V}{I} = \frac{l}{\sigma A} \quad (6.2.6)$$

is the resistance of the conductor. The equation

$$\Delta V = IR \quad (6.2.7)$$

is the “macroscopic” version of the Ohm’s law. The SI unit of R is the ohm (Ω , Greek letter Omega), where

$$1 \Omega \equiv \frac{1 \text{ V}}{1 \text{ A}} \quad (6.2.8)$$

Once again, a material that obeys the above relation is ohmic, and non-ohmic if the relation is not obeyed. Most metals, with good conductivity and low resistivity, are ohmic. We shall focus mainly on ohmic materials.

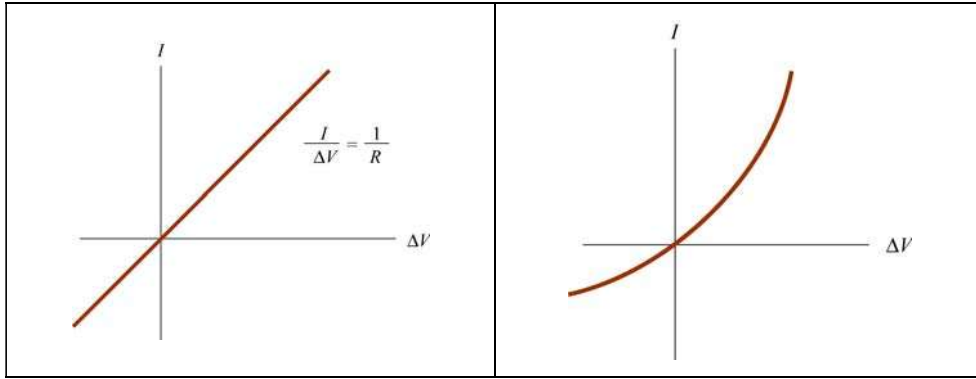

Figure 6.2.2 Ohmic vs. Non-ohmic behavior.

The resistivity ρ of a material is defined as the reciprocal of conductivity,

$$\rho = \frac{1}{\sigma} = \frac{m_e}{ne^2\tau} \quad (6.2.9)$$

From the above equations, we see that ρ can be related to the resistance R of an object by

$$\rho = \frac{E}{J} = \frac{\Delta V / l}{I / A} = \frac{RA}{l}$$

or

$$R = \frac{\rho l}{A} \quad (6.2.10)$$

The resistivity of a material actually varies with temperature T . For metals, the variation is linear over a large range of T :

$$\rho = \rho_0 [1 + \alpha(T - T_0)] \quad (6.2.11)$$

where α is the *temperature coefficient of resistivity*. Typical values of ρ , σ and α (at 20°C) for different types of materials are given in the Table below.

Material	Resistivity ρ ($\Omega \cdot \text{m}$)	Conductivity σ ($\Omega \cdot \text{m}$) ⁻¹	Temperature Coefficient α ($^{\circ}\text{C}$) ⁻¹
Elements			
Silver	1.59×10^{-8}	6.29×10^7	0.0038
Copper	1.72×10^{-8}	5.81×10^7	0.0039
Aluminum	2.82×10^{-8}	3.55×10^7	0.0039
Tungsten	5.6×10^{-8}	1.8×10^7	0.0045
Iron	10.0×10^{-8}	1.0×10^7	0.0050
Platinum	10.6×10^{-8}	1.0×10^7	0.0039
Alloys			
Brass	7×10^{-8}	1.4×10^7	0.002
Manganin	44×10^{-8}	0.23×10^7	1.0×10^{-5}
Nichrome	100×10^{-8}	0.1×10^7	0.0004
Semiconductors			
Carbon (graphite)	3.5×10^{-5}	2.9×10^4	-0.0005
Germanium (pure)	0.46	2.2	-0.048
Silicon (pure)	640	1.6×10^{-3}	-0.075
Insulators			
Glass	$10^{10} - 10^{14}$	$10^{-14} - 10^{-10}$	
Sulfur	10^{15}	10^{-15}	
Quartz (fused)	75×10^{16}	1.33×10^{-18}	

6.3 Electrical Energy and Power

Consider a circuit consisting of a battery and a resistor with resistance R (Figure 6.3.1). Let the potential difference between two points a and b be $\Delta V = V_b - V_a > 0$. If a charge Δq is moved from a through the battery, its electric potential energy is increased by $\Delta U = \Delta q \Delta V$. On the other hand, as the charge moves across the resistor, the potential energy is decreased due to collisions with atoms in the resistor. If we neglect the internal resistance of the battery and the connecting wires, upon returning to a the potential energy of Δq remains unchanged.

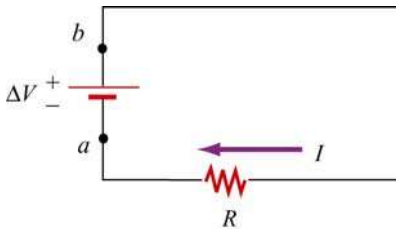

Figure 6.3.1 A circuit consisting of a battery and a resistor of resistance R .

Thus, the rate of energy loss through the resistor is given by

$$P = \frac{\Delta U}{\Delta t} = \left(\frac{\Delta q}{\Delta t} \right) \Delta V = I \Delta V \quad (6.3.1)$$

This is precisely the power supplied by the battery. Using $\Delta V = IR$, one may rewrite the above equation as

$$P = I^2 R = \frac{(\Delta V)^2}{R} \quad (6.3.2)$$

6.4 Summary

- The **electric current** is defined as:

$$I = \frac{dQ}{dt}$$

- The average current in a conductor is

$$I_{\text{avg}} = nq v_d A$$

where n is the number density of the charge carriers, q is the charge each carrier has, v_d is the **drift speed**, and A is the cross-sectional area.

- The **current density** J through the cross sectional area of the wire is

$$\vec{J} = nq \vec{v}_d$$

- Microscopic **Ohm's law**: the current density is proportional to the electric field, and the constant of proportionality is called **conductivity** σ :

$$\vec{J} = \sigma \vec{E}$$

- The reciprocal of conductivity σ is called **resistivity** ρ :

$$\rho = \frac{1}{\sigma}$$

- Macroscopic Ohm's law: The **resistance** R of a conductor is the ratio of the potential difference ΔV between the two ends of the conductor and the current I :

$$R = \frac{\Delta V}{I}$$

- Resistance is related to resistivity by

$$R = \frac{\rho l}{A}$$

where l is the length and A is the cross-sectional area of the conductor.

- The **drift velocity** of an electron in the conductor is

$$\vec{v}_d = -\frac{e\vec{E}}{m_e} \tau$$

where m_e is the mass of an electron, and τ is the average time between successive collisions.

- The resistivity of a metal is related to τ by

$$\rho = \frac{1}{\sigma} = \frac{m_e}{ne^2\tau}$$

- The temperature variation of resistivity of a conductor is

$$\rho = \rho_0 [1 + \alpha(T - T_0)]$$

where α is the **temperature coefficient of resistivity**.

- **Power**, or rate at which energy is delivered to the resistor is

$$P = I\Delta V = I^2R = \frac{(\Delta V)^2}{R}$$

6.5 Solved Problems

6.5.1 Resistivity of a Cable

A 3000-km long cable consists of seven copper wires, each of diameter 0.73 mm, bundled together and surrounded by an insulating sheath. Calculate the resistance of the cable. Use $3 \times 10^{-6} \Omega \cdot \text{cm}$ for the resistivity of the copper.

Solution:

The resistance R of a conductor is related to the resistivity ρ by $R = \rho l / A$, where l and A are the length of the conductor and the cross-sectional area, respectively. Since the cable consists of $N = 7$ copper wires, the total cross sectional area is

$$A = N\pi r^2 = N \frac{\pi d^2}{4} = 7 \frac{\pi (0.073 \text{ cm})^2}{4}$$

The resistance then becomes

$$R = \frac{\rho l}{A} = \frac{(3 \times 10^{-6} \Omega \cdot \text{cm})(3 \times 10^8 \text{ cm})}{7\pi(0.073 \text{ cm})^2 / 4} = 3.1 \times 10^4 \Omega$$

6.5.2 Charge at a Junction

Show that the total amount of charge at the junction of the two materials in Figure 6.5.1 is $\epsilon_0 I (\sigma_2^{-1} - \sigma_1^{-1})$, where I is the current flowing through the junction, and σ_1 and σ_2 are the conductivities for the two materials.

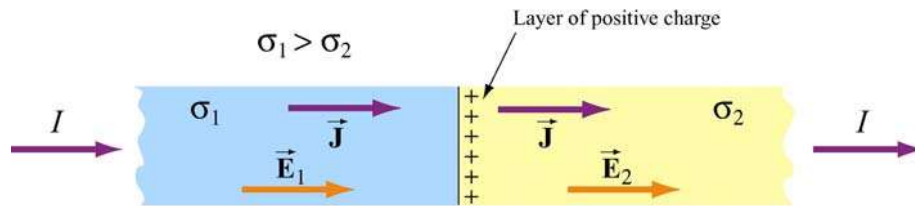

Figure 6.5.1 Charge at a junction.

Solution:

In a steady state of current flow, the normal component of the current density \vec{J} must be the same on both sides of the junction. Since $J = \sigma E$, we have $\sigma_1 E_1 = \sigma_2 E_2$

or

$$E_2 = \left(\frac{\sigma_1}{\sigma_2} \right) E_1$$

Let the charge on the interface be q_{in} , we have, from the Gauss's law:

$$\oiint_S \vec{E} \cdot d\vec{A} = (E_2 - E_1) A = \frac{q_{in}}{\epsilon_0}$$

or

$$E_2 - E_1 = \frac{q_{\text{in}}}{A\epsilon_0}$$

Substituting the expression for E_2 from above then yields

$$q_{\text{in}} = \epsilon_0 A E_1 \left(\frac{\sigma_1}{\sigma_2} - 1 \right) = \epsilon_0 A \sigma_1 E_1 \left(\frac{1}{\sigma_2} - \frac{1}{\sigma_1} \right)$$

Since the current is $I = JA = (\sigma_1 E_1) A$, the amount of charge on the interface becomes

$$q_{\text{in}} = \epsilon_0 I \left(\frac{1}{\sigma_2} - \frac{1}{\sigma_1} \right)$$

6.5.3 Drift Velocity

The resistivity of seawater is about $25 \Omega \cdot \text{cm}$. The charge carriers are chiefly Na^+ and Cl^- ions, and of each there are about $3 \times 10^{20} / \text{cm}^3$. If we fill a plastic tube 2 meters long with seawater and connect a 12-volt battery to the electrodes at each end, what is the resulting average drift velocity of the ions, in cm/s ?

Solution:

The current in a conductor of cross sectional area A is related to the drift speed v_d of the charge carriers by

$$I = enAv_d$$

where n is the number of charges per unit volume. We can then rewrite the Ohm's law as

$$V = IR = (enAv_d) \left(\frac{\rho l}{A} \right) = nev_d \rho l$$

which yields

$$v_d = \frac{V}{ne\rho l}$$

Substituting the values, we have

$$v_d = \frac{12\text{V}}{(6 \times 10^{20} / \text{cm}^3)(1.6 \times 10^{-19} \text{C})(25 \Omega \cdot \text{cm})(200 \text{cm})} = 2.5 \times 10^{-5} \frac{\text{V} \cdot \text{cm}}{\text{C} \cdot \Omega} = 2.5 \times 10^{-5} \frac{\text{cm}}{\text{s}}$$

In converting the units we have used

$$\frac{V}{\Omega \cdot C} = \left(\frac{V}{\Omega} \right) \frac{1}{C} = \frac{A}{C} = s^{-1}$$

6.5.4 Resistance of a Truncated Cone

Consider a material of resistivity ρ in a shape of a truncated cone of altitude h , and radii a and b , for the right and the left ends, respectively, as shown in the Figure 6.5.2.

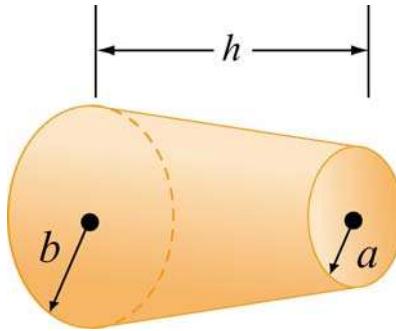

Figure 6.5.2 A truncated Cone.

Assuming that the current is distributed uniformly throughout the cross-section of the cone, what is the resistance between the two ends?

Solution:

Consider a thin disk of radius r at a distance x from the left end. From the figure shown on the right, we have

$$\frac{b-r}{x} = \frac{b-a}{h}$$

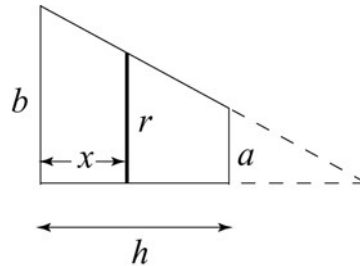

or

$$r = (a-b) \frac{x}{h} + b$$

Since resistance R is related to resistivity ρ by $R = \rho l / A$, where l is the length of the conductor and A is the cross section, the contribution to the resistance from the disk having a thickness dy is

$$dR = \frac{\rho dx}{\pi r^2} = \frac{\rho dx}{\pi [b + (a-b)x/h]^2}$$

Straightforward integration then yields

$$R = \int_0^h \frac{\rho dx}{\pi[b + (a-b)x/h]^2} = \frac{\rho h}{\pi ab}$$

where we have used

$$\int \frac{du}{(\alpha u + \beta)^2} = -\frac{1}{\alpha(\alpha u + \beta)}$$

Note that if $b = a$, Eq. (6.2.9) is reproduced.

6.5.5 Resistance of a Hollow Cylinder

Consider a hollow cylinder of length L and inner radius a and outer radius b , as shown in Figure 6.5.3. The material has resistivity ρ .

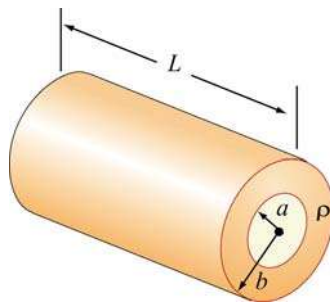

Figure 6.5.3 A hollow cylinder.

- (a) Suppose a potential difference is applied between the ends of the cylinder and produces a current flowing parallel to the axis. What is the resistance measured?
- (b) If instead the potential difference is applied between the inner and outer surfaces so that current flows radially outward, what is the resistance measured?

Solution:

(a) When a potential difference is applied between the ends of the cylinder, current flows parallel to the axis. In this case, the cross-sectional area is $A = \pi(b^2 - a^2)$, and the resistance is given by

$$R = \frac{\rho L}{A} = \frac{\rho L}{\pi(b^2 - a^2)}$$

(b) Consider a differential element which is made up of a thin cylinder of inner radius r and outer radius $r + dr$ and length L . Its contribution to the resistance of the system is given by

$$dR = \frac{\rho dl}{A} = \frac{\rho dr}{2\pi rL}$$

where $A = 2\pi rL$ is the area normal to the direction of current flow. The total resistance of the system becomes

$$R = \int_a^b \frac{\rho dr}{2\pi rL} = \frac{\rho}{2\pi L} \ln\left(\frac{b}{a}\right)$$

6.6 Conceptual Questions

1. Two wires A and B of circular cross-section are made of the same metal and have equal lengths, but the resistance of wire A is four times greater than that of wire B. Find the ratio of their cross-sectional areas.
2. From the point of view of atomic theory, explain why the resistance of a material increases as its temperature increases.
3. Two conductors A and B of the same length and radius are connected across the same potential difference. The resistance of conductor A is twice that of B. To which conductor is more power delivered?

6.7 Additional Problems

6.7.1 Current and Current Density

A sphere of radius 10 mm that carries a charge of $8 \text{ nC} = 8 \times 10^{-9} \text{ C}$ is whirled in a circle at the end of an insulated string. The rotation frequency is $100\pi \text{ rad/s}$.

- (a) What is the basic definition of current in terms of charge?
- (b) What average current does this rotating charge represent?
- (c) What is the average current density over the area traversed by the sphere?

6.7.2 Power Loss and Ohm's Law

A 1500 W radiant heater is constructed to operate at 115 V.

- (a) What will be the current in the heater? [Ans. ~ 10 A]
- (b) What is the resistance of the heating coil? [Ans. ~ 10 Ω]
- (c) How many kilocalories are generated in one hour by the heater? (1 Calorie = 4.18 J)

6.7.3 Resistance of a Cone

A copper resistor of resistivity ρ is in the shape of a cylinder of radius b and length L_1 appended to a truncated right circular cone of length L_2 and end radii b and a as shown in Figure 6.7.1.

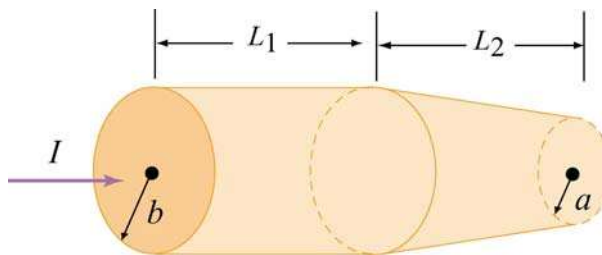

Figure 6.7.1

- (a) What is the resistance of the cylindrical portion of the resistor?
- (b) What is the resistance of the entire resistor? (Hint: For the tapered portion, it is necessary to write down the incremental resistance dR of a small slice, dx , of the resistor at an arbitrary position, x , and then to sum the slices by integration. If the taper is small, one may assume that the current density is uniform across any cross section.)
- (c) Show that your answer reduces to the expected expression if $a = b$.
- (d) If $L_1 = 100$ mm, $L_2 = 50$ mm, $a = 0.5$ mm, $b = 1.0$ mm, what is the resistance?

6.7.4 Current Density and Drift Speed

- (a) A group of charges, each with charge q , moves with velocity \vec{v} . The number of particles per unit volume is n . What is the current density \vec{J} of these charges, in magnitude and direction? Make sure that your answer has units of A/m².
- (b) We want to calculate how long it takes an electron to get from a car battery to the starter motor after the ignition switch is turned. Assume that the current flowing is 115 A, and that the electrons travel through copper wire with cross-sectional area 31.2 mm² and length 85.5 cm. What is the current density in the wire? The number density of the conduction electrons in copper is 8.49×10^{28} /m³. Given this number density and the current density, what is the drift speed of the electrons? How long does it take for an

electron starting at the battery to reach the starter motor? [Ans: $3.69 \times 10^6 \text{ A/m}^2$, $2.71 \times 10^{-4} \text{ m/s}$, 52.5 min.]

6.7.5 Current Sheet

A *current sheet*, as the name implies, is a plane containing currents flowing in one direction in that plane. One way to construct a sheet of current is by running many parallel wires in a plane, say the yz -plane, as shown in Figure 6.7.2(a). Each of these wires carries current I out of the page, in the $-\hat{j}$ direction, with n wires per unit length in the z -direction, as shown in Figure 6.7.2(b). Then the current per unit length in the z direction is nI . We will use the symbol K to signify current per unit length, so that $K = nI$ here.

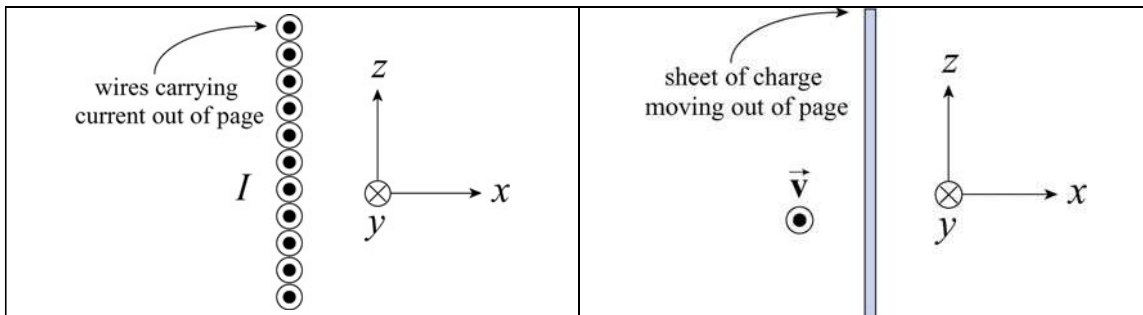

Figure 6.7.2 A current sheet.

Another way to construct a current sheet is to take a non-conducting sheet of charge with fixed charge per unit area σ and move it with some speed in the direction you want current to flow. For example, in the sketch to the left, we have a sheet of charge moving out of the page with speed v . The direction of current flow is out of the page.

(a) Show that the magnitude of the current per unit length in the z direction, K , is given by σv . Check that this quantity has the proper dimensions of current per length. This is in fact a vector relation, $\vec{K}(t) = \sigma \vec{v}(t)$, since the sense of the current flow is in the same direction as the velocity of the positive charges.

(b) A belt transferring charge to the high-potential inner shell of a Van de Graaff accelerator at the rate of 2.83 mC/s . If the width of the belt carrying the charge is 50 cm and the belt travels at a speed of 30 m/s , what is the surface charge density on the belt? [Ans: $189 \mu\text{C/m}^2$]

6.7.6 Resistance and Resistivity

A wire with a resistance of 6.0Ω is drawn out through a die so that its new length is three times its original length. Find the resistance of the longer wire, assuming that the

resistivity and density of the material are not changed during the drawing process. [Ans: 54 Ω].

6.7.7 Power, Current, and Voltage

A 100-W light bulb is plugged into a standard 120-V outlet. (a) How much does it cost per month (31 days) to leave the light turned on? Assume electricity costs 6 cents per kW·h. (b) What is the resistance of the bulb? (c) What is the current in the bulb? [Ans: (a) \$4.46; (b) 144 Ω ; (c) 0.833 A].

6.7.8 Charge Accumulation at the Interface

Figure 6.7.3 shows a three-layer sandwich made of two resistive materials with resistivities ρ_1 and ρ_2 . From left to right, we have a layer of material with resistivity ρ_1 of width $d/3$, followed by a layer of material with resistivity ρ_2 , also of width $d/3$, followed by another layer of the first material with resistivity ρ_1 , again of width $d/3$.

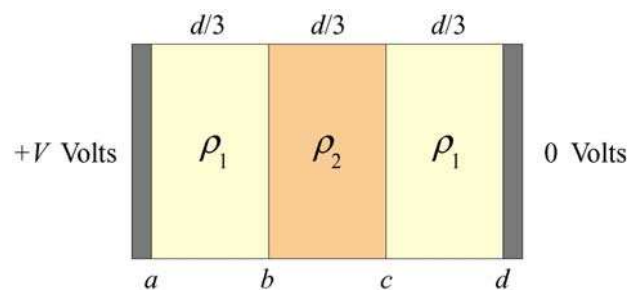

Figure 6.7.3 Charge accumulation at interface.

The cross-sectional area of all of these materials is A . The resistive sandwich is bounded on either side by metallic conductors (black regions). Using a battery (not shown), we maintain a potential difference V across the entire sandwich, between the metallic conductors. The left side of the sandwich is at the higher potential (*i.e.*, the electric fields point from left to right).

There are four interfaces between the various materials and the conductors, which we label a through d , as indicated on the sketch. A steady current I flows through this sandwich from left to right, corresponding to a current density $J = I/A$.

(a) What are the electric fields \vec{E}_1 and \vec{E}_2 in the two different dielectric materials? To obtain these fields, assume that the current density is the same in every layer. Why must this be true? [Ans: All fields point to the right, $E_1 = \rho_1 I/A$, $E_2 = \rho_2 I/A$; the current densities must be the same in a steady state, otherwise there would be a continuous buildup of charge at the interfaces to unlimited values.]

(b) What is the total resistance R of this sandwich? Show that your expression reduces to the expected result if $\rho_1 = \rho_2 = \rho$. [Ans: $R = d(2\rho_1 + \rho_2)/3A$; if $\rho_1 = \rho_2 = \rho$, then $R = d\rho/A$, as expected.]

(c) As we move from right to left, what are the changes in potential across the three layers, in terms of V and the resistivities? [Ans: $V\rho_1/(2\rho_1 + \rho_2)$, $V\rho_2/(2\rho_1 + \rho_2)$, $V\rho_1/(2\rho_1 + \rho_2)$, summing to a total potential drop of V , as required].

(d) What are the charges per unit area, σ_a through σ_d , at the interfaces? Use Gauss's Law and assume that the electric field in the conducting caps is zero. [Ans: $\sigma_a = -\sigma_d = 3\varepsilon_0 V \rho_1 / d(2\rho_1 + \rho_2)$, $\sigma_b = -\sigma_c = 3\varepsilon_0 V (\rho_2 - \rho_1) / d(2\rho_1 + \rho_2)$.]

(e) Consider the limit $\rho_2 \gg \rho_1$. What do your answers above reduce to in this limit?

Chapter 7

Direct-Current Circuits

7.1	Introduction.....	1
7.2	Electromotive Force.....	2
7.3	Resistors in Series and in Parallel.....	4
7.4	Kirchhoff's Circuit Rules.....	6
7.5	Voltage-Current Measurements.....	8
7.6	RC Circuit.....	9
7.6.1	Charging a Capacitor.....	9
7.6.2	Discharging a Capacitor.....	13
7.7	Summary.....	15
7.8	Problem-Solving Strategy: Applying Kirchhoff's Rules.....	15
7.9	Solved Problems.....	18
7.9.1	Equivalent Resistance.....	18
7.9.2	Variable Resistance.....	19
7.9.3	RC Circuit.....	20
7.9.4	Parallel vs. Series Connections.....	21
7.9.5	Resistor Network.....	24
7.10	Conceptual Questions.....	25
7.11	Additional Problems.....	25
7.11.1	Resistive Circuits.....	25
7.11.2	Multiloop Circuit.....	26
7.11.3	Power Delivered to the Resistors.....	26
7.11.4	Resistor Network.....	26
7.11.5	RC Circuit.....	27
7.11.6	Resistors in Series and Parallel.....	27

Direct-Current Circuits

7.1 Introduction

Electrical circuits connect power supplies to *loads* such as resistors, motors, heaters, or lamps. The connection between the supply and the load is made by soldering with wires that are often called *leads*, or with many kinds of connectors and terminals. Energy is delivered from the source to the user on demand at the flick of a switch. Sometimes many circuit elements are connected to the same lead, which is called a *common lead* for those elements. Various parts of the circuits are called circuit elements, which can be in series or in parallel, as we have already seen in the case of capacitors.

Elements are said to be in *parallel* when they are connected across the same potential difference (see Figure 7.1.1a).

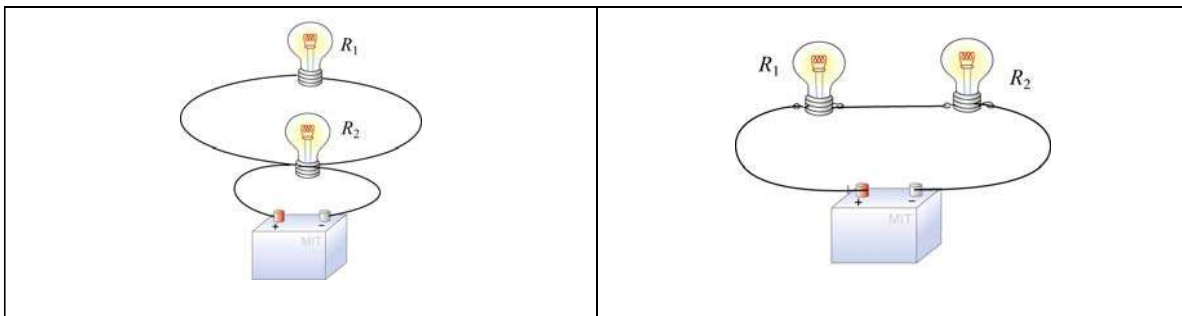

Figure 7.1.1 Elements connected (a) in parallel, and (b) in series.

Generally, loads are connected in parallel across the power supply. On the other hand, when the elements are connected one after another, so that the current passes through each element without any branches, the elements are in *series* (see Figure 7.1.1b).

There are pictorial diagrams that show wires and components roughly as they appear, and schematic diagrams that use conventional symbols, somewhat like road maps. Some frequently used symbols are shown below:

Voltage Source	
Resistor	
Switch	

Often there is a switch in series; when the switch is open the load is disconnected; when the switch is closed, the load is connected.

One can have closed circuits, through which current flows, or open circuits in which there are no currents. Usually by accident, wires may touch, causing a *short circuit*. Most of the current flows through the short, very little will flow through the load. This may burn out a piece of electrical equipment such as a transformer. To prevent damage, a fuse or circuit breaker is put in series. When there is a short the fuse blows, or the breaker opens.

In electrical circuits, a point (or some common lead) is chosen as the *ground*. This point is assigned an arbitrary voltage, usually zero, and the voltage V at any point in the circuit is defined as the voltage difference between that point and ground.

7.2 Electromotive Force

In the last Chapter, we have shown that electrical energy must be supplied to maintain a constant current in a closed circuit. The source of energy is commonly referred to as the electromotive force, or emf (symbol ε). Batteries, solar cells and thermocouples are some examples of emf source. They can be thought of as a “charge pump” that moves charges from lower potential to the higher one. Mathematically emf is defined as

$$\varepsilon \equiv \frac{dW}{dq} \quad (7.2.1)$$

which is the work done to move a unit charge in the direction of higher potential. The SI unit for ε is the volt (V).

Consider a simple circuit consisting of a battery as the emf source and a resistor of resistance R , as shown in Figure 7.2.1.

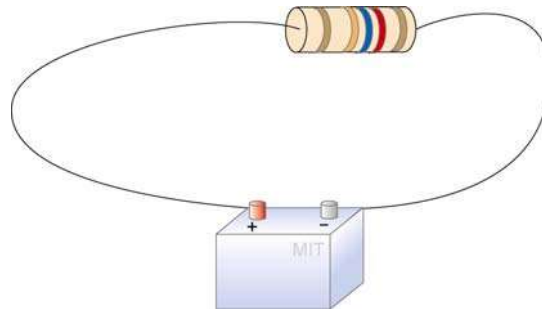
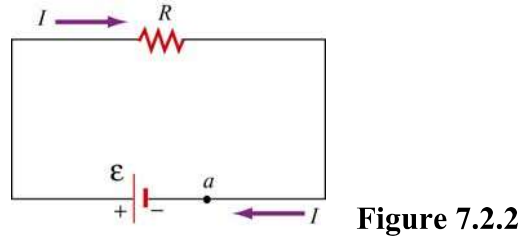

Figure 7.2.1 A simple circuit consisting of a battery and a resistor

Assuming that the battery has no internal resistance, the potential difference ΔV (or terminal voltage) between the positive and the negative terminals of the battery is equal to the emf ε . To drive the current around the circuit, the battery undergoes a discharging process which converts chemical energy to emf (recall that the dimensions of emf are the same as energy per charge). The current I can be found by noting that no work is done in moving a charge q around a closed loop due to the conservative nature of the electrostatic force:

$$W = -q \oint \vec{E} \cdot d\vec{s} = 0 \quad (7.2.2)$$

Let point a in Figure 7.2.2 be the starting point.



When crossing from the negative to the positive terminal, the potential increases by ε . On the other hand, as we cross the resistor, the potential decreases by an amount IR , and the potential energy is converted into thermal energy in the resistor. Assuming that the connecting wire carries no resistance, upon completing the loop, the net change in potential difference is zero,

$$\varepsilon - IR = 0 \quad (7.2.3)$$

which implies

$$I = \frac{\varepsilon}{R} \quad (7.2.4)$$

However, a real battery always carries an internal resistance r (Figure 7.2.3a),

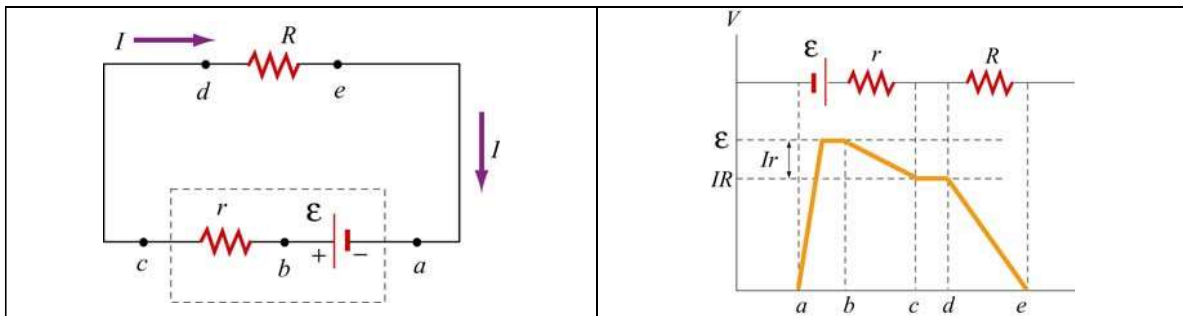

Figure 7.2.3 (a) Circuit with an emf source having an internal resistance r and a resistor of resistance R . (b) Change in electric potential around the circuit.

and the potential difference across the battery terminals becomes

$$\Delta V = \varepsilon - Ir \quad (7.2.5)$$

Since there is no net change in potential difference around a closed loop, we have

$$\varepsilon - Ir - IR = 0 \quad (7.2.6)$$

or

$$I = \frac{\varepsilon}{R + r} \quad (7.2.7)$$

Figure 7.2.3(b) depicts the change in electric potential as we traverse the circuit clockwise. From the Figure, we see that the highest voltage is immediately after the battery. The voltage drops as each resistor is crossed. Note that the voltage is essentially constant along the wires. This is because the wires have a negligibly small resistance compared to the resistors.

For a source with emf ε , the power or the rate at which energy is delivered is

$$P = I\varepsilon = I(IR + Ir) = I^2R + I^2r \quad (7.2.8)$$

That the power of the source emf is equal to the sum of the power dissipated in both the internal and load resistance is required by energy conservation.

7.3 Resistors in Series and in Parallel

The two resistors R_1 and R_2 in Figure 7.3.1 are connected in series to a voltage source ΔV . By current conservation, the same current I is flowing through each resistor.

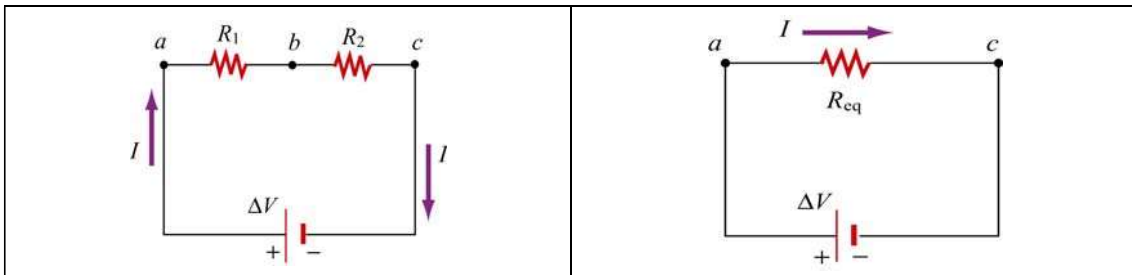

Figure 7.3.1 (a) Resistors in series. (b) Equivalent circuit.

The total voltage drop from a to c across both elements is the sum of the voltage drops across the individual resistors:

$$\Delta V = I R_1 + I R_2 = I (R_1 + R_2) \quad (7.3.1)$$

The two resistors in series can be replaced by one equivalent resistor R_{eq} (Figure 7.3.1b) with the identical voltage drop $\Delta V = I R_{\text{eq}}$ which implies that

$$R_{\text{eq}} = R_1 + R_2 \quad (7.3.2)$$

The above argument can be extended to N resistors placed in series. The equivalent resistance is just the sum of the original resistances,

$$R_{\text{eq}} = R_1 + R_2 + \dots = \sum_{i=1}^N R_i \quad (7.3.3)$$

Notice that if one resistance R_1 is much larger than the other resistances R_i , then the equivalent resistance R_{eq} is approximately equal to the largest resistor R_1 .

Next let's consider two resistors R_1 and R_2 that are connected in parallel across a voltage source ΔV (Figure 7.3.2a).

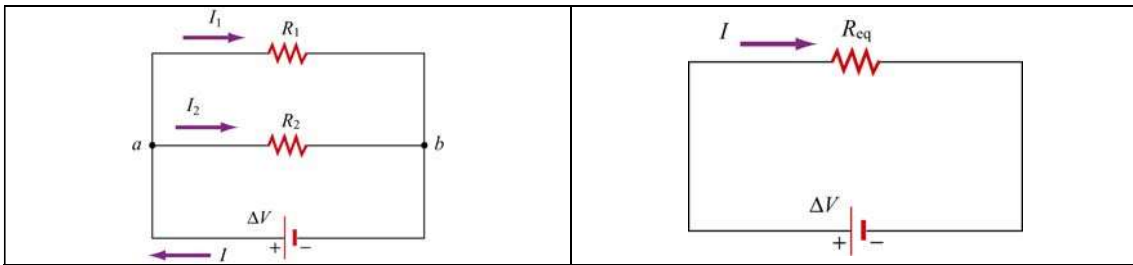

Figure 7.3.2 (a) Two resistors in parallel. (b) Equivalent resistance

By current conservation, the current I that passes through the voltage source must divide into a current I_1 that passes through resistor R_1 and a current I_2 that passes through resistor R_2 . Each resistor individually satisfies Ohm's law, $\Delta V_1 = I_1 R_1$ and $\Delta V_2 = I_2 R_2$. However, the potential across the resistors are the same, $\Delta V_1 = \Delta V_2 = \Delta V$. Current conservation then implies

$$I = I_1 + I_2 = \frac{\Delta V}{R_1} + \frac{\Delta V}{R_2} = \Delta V \left(\frac{1}{R_1} + \frac{1}{R_2} \right) \quad (7.3.4)$$

The two resistors in parallel can be replaced by one equivalent resistor R_{eq} with $\Delta V = IR_{\text{eq}}$ (Figure 7.3.2b). Comparing these results, the equivalent resistance for two resistors that are connected in parallel is given by

$$\frac{1}{R_{\text{eq}}} = \frac{1}{R_1} + \frac{1}{R_2} \quad (7.3.5)$$

This result easily generalizes to N resistors connected in parallel

$$\frac{1}{R_{\text{eq}}} = \frac{1}{R_1} + \frac{1}{R_2} + \frac{1}{R_3} + \dots = \sum_{i=1}^N \frac{1}{R_i} \quad (7.3.6)$$

When one resistance R_1 is much smaller than the other resistances R_i , then the equivalent resistance R_{eq} is approximately equal to the smallest resistor R_1 . In the case of two resistors,

$$R_{eq} = \frac{R_1 R_2}{R_1 + R_2} \approx \frac{R_1 R_2}{R_2} = R_1$$

This means that almost all of the current that enters the node point will pass through the branch containing the smallest resistance. So, when a short develops across a circuit, all of the current passes through this path of nearly zero resistance.

7.4 Kirchhoff's Circuit Rules

In analyzing circuits, there are two fundamental (Kirchhoff's) rules:

1. Junction Rule

At any point where there is a junction between various current carrying branches, by current conservation the sum of the currents into the node must equal the sum of the currents out of the node (otherwise charge would build up at the junction);

$$\sum I_{in} = \sum I_{out} \quad (7.4.1)$$

As an example, consider Figure 7.4.1 below:

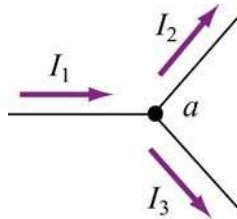

Figure 7.4.1 Kirchhoff's junction rule.

According to the junction rule, the three currents are related by

$$I_1 = I_2 + I_3$$

2. Loop Rule

The sum of the voltage drops ΔV , across any circuit elements that form a closed circuit is zero:

$$\sum_{\text{closed loop}} \Delta V = 0 \quad (7.4.2)$$

The rules for determining ΔV across a resistor and a battery with a designated travel direction are shown below:

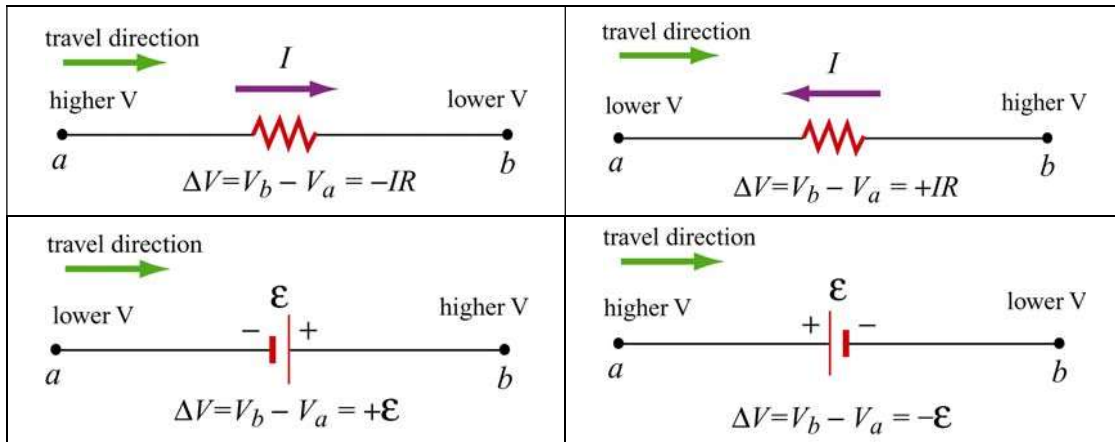

Figure 7.4.2 Convention for determining ΔV .

Note that the choice of travel direction is arbitrary. The same equation is obtained whether the closed loop is traversed clockwise or counterclockwise.

As an example, consider a voltage source V_{in} that is connected in series to two resistors, R_1 and R_2

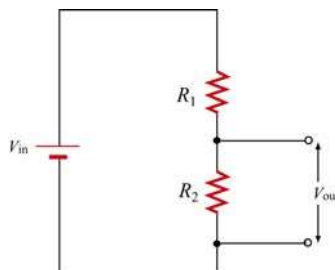

Figure 7.4.3 Voltage divider.

The voltage difference, V_{out} , across resistor R_2 will be less than V_{in} . This circuit is called a voltage divider. From the loop rule,

$$V_{in} - IR_1 - IR_2 = 0 \quad (7.4.3)$$

So the current in the circuit is given by

$$I = \frac{V_{in}}{R_1 + R_2} \quad (7.4.4)$$

Thus the voltage difference, V_{out} , across resistor R_2 is given by

$$V_{out} = IR_2 = \frac{R_2}{R_1 + R_2} V_{in} \quad (7.4.5)$$

Note that the ratio of the voltages characterizes the voltage divider and is determined by the resistors:

$$\frac{V_{out}}{V_{in}} = \frac{R_2}{R_1 + R_2} \quad (7.4.6)$$

7.5 Voltage-Current Measurements

Any instrument that measures voltage or current will disturb the circuit under observation. Some devices, known as ammeters, will indicate the flow of current by a meter movement or a digital display. There will be some voltage drop due to the resistance of the flow of current through the ammeter. An ideal ammeter has zero resistance, but in the case of your multimeter, the resistance is 1Ω on the 250 mDCA range. The drop of 0.25 V may or may not be negligible; knowing the meter resistance allows one to correct for its effect on the circuit.

An ammeter can be converted to a voltmeter by putting a resistor R in series with the coil movement. The voltage across some circuit element can be determined by connecting the coil movement and resistor in parallel with the circuit element. This causes a small amount of current to flow through the coil movement. The voltage across the element can now be determined by measuring I and computing the voltage from $\Delta V = IR$, which is read on a calibrated scale. The larger the resistance R , the smaller the amount of current is diverted through the coil. Thus an ideal voltmeter would have an infinite resistance.

Resistor Value Chart					
0	Black	4	Yellow	8	Gray
1	Brown	5	Green	9	White
2	Red	6	Blue	-1	Gold
3	Orange	7	Violet	-2	Silver

The colored bands on a composition resistor specify numbers according to the chart above (2-7 follow the rainbow spectrum). Starting from the end to which the bands are closest, the first two numbers specify the significant figures of the value of the resistor and the third number represents a power of ten by which the first two numbers are to be multiplied (gold is 10^{-1}). The fourth specifies the “tolerance,” or precision, gold being

5% and silver 10%. As an example, a 43-Ω (43 ohms) resistor with 5% tolerance is represented by yellow, orange, black, gold.

7.6 RC Circuit

7.6.1 Charging a Capacitor

Consider the circuit shown below. The capacitor is connected to a DC voltage source of emf ϵ . At time $t=0$, the switch S is closed. The capacitor initially is uncharged, $q(t=0)=0$.

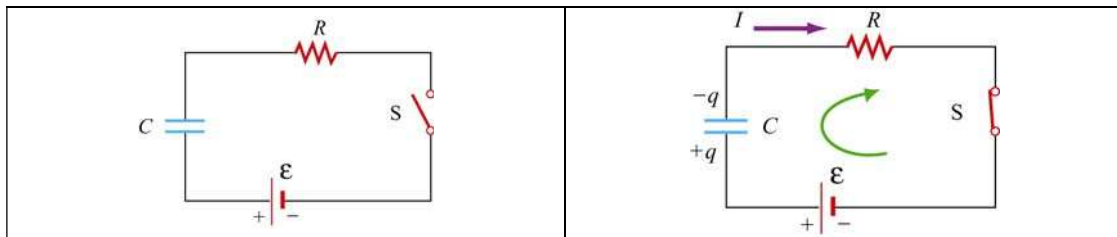

Figure 7.6.1 (a) RC circuit diagram for $t < 0$. (b) Circuit diagram for $t > 0$.

In particular for $t < 0$, there is no voltage across the capacitor so the capacitor acts like a short circuit. At $t=0$, the switch is closed and current begins to flow according to

$$I_0 = \frac{\epsilon}{R} \quad (7.6.1)$$

At this instant, the potential difference from the battery terminals is the same as that across the resistor. This initiates the charging of the capacitor. As the capacitor starts to charge, the voltage across the capacitor increases in time

$$V_C(t) = \frac{q(t)}{C} \quad (7.6.2)$$

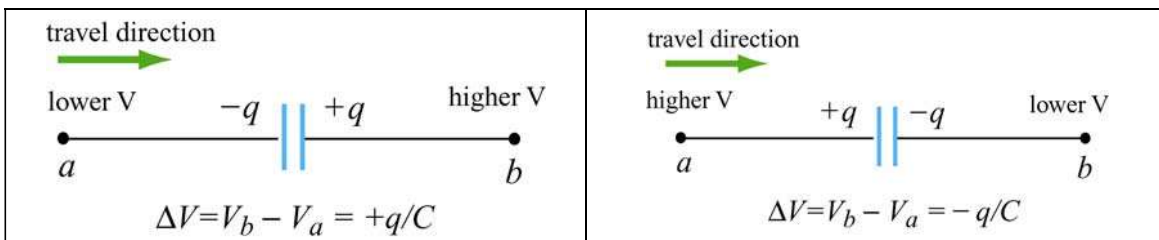

Figure 7.6.2 Kirchhoff's rule for capacitors.

Using Kirchhoff's loop rule shown in Figure 7.6.2 for capacitors and traversing the loop clockwise, we obtain

$$\begin{aligned}
0 &= \mathcal{E} - I(t)R - V_C(t) \\
&= \mathcal{E} - \frac{dq}{dt}R - \frac{q}{C}
\end{aligned}
\tag{7.6.3}$$

where we have substituted $I = +dq/dt$ for the current. Since I must be the same in all parts of the series circuit, the current across the resistance R is equal to the rate of increase of charge on the capacitor plates. The current flow in the circuit will continue to decrease because the charge already present on the capacitor makes it harder to put more charge on the capacitor. Once the charge on the capacitor plates reaches its maximum value Q , the current in the circuit will drop to zero. This is evident by rewriting the loop law as

$$I(t)R = \mathcal{E} - V_C(t) \tag{7.6.4}$$

Thus, the charging capacitor satisfies a first order differential equation that relates the rate of change of charge to the charge on the capacitor:

$$\frac{dq}{dt} = \frac{1}{R} \left(\mathcal{E} - \frac{q}{C} \right) \tag{7.6.5}$$

This equation can be solved by the method of separation of variables. The first step is to separate terms involving charge and time, (this means putting terms involving dq and q on one side of the equality sign and terms involving dt on the other side),

$$\frac{dq}{\left(\mathcal{E} - \frac{q}{C} \right)} = \frac{1}{R} dt \quad \Rightarrow \quad \frac{dq}{q - C\mathcal{E}} = -\frac{1}{RC} dt \tag{7.6.6}$$

Now we can integrate both sides of the above equation,

$$\int_0^q \frac{dq'}{q' - C\mathcal{E}} = -\frac{1}{RC} \int_0^t dt' \tag{7.6.7}$$

which yields

$$\ln \left(\frac{q - C\mathcal{E}}{-C\mathcal{E}} \right) = -\frac{t}{RC} \tag{7.6.8}$$

This can now be exponentiated using the fact that $\exp(\ln x) = x$ to yield

$$\boxed{q(t) = C\mathcal{E} \left(1 - e^{-t/RC} \right) = Q \left(1 - e^{-t/RC} \right)} \tag{7.6.9}$$

where $Q = C\varepsilon$ is the maximum amount of charge stored on the plates. The time dependence of $q(t)$ is plotted in Figure 7.6.3 below:

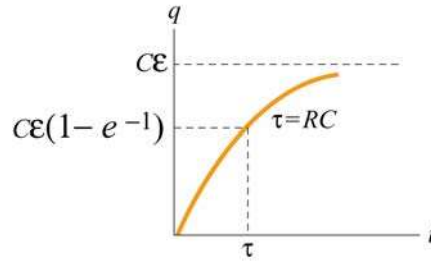

Figure 7.6.3 Charge as a function of time during the charging process.

Once we know the charge on the capacitor we also can determine the voltage across the capacitor,

$$V_c(t) = \frac{q(t)}{C} = \varepsilon(1 - e^{-t/RC}) \quad (7.6.10)$$

The graph of voltage as a function of time has the same form as Figure 7.6.3. From the figure, we see that after a sufficiently long time the charge on the capacitor approaches the value

$$q(t = \infty) = C\varepsilon = Q \quad (7.6.11).$$

At that time, the voltage across the capacitor is equal to the applied voltage source and the charging process effectively ends,

$$V_c = \frac{q(t = \infty)}{C} = \frac{Q}{C} = \varepsilon \quad (7.6.12).$$

The current that flows in the circuit is equal to the derivative in time of the charge,

$$I(t) = \frac{dq}{dt} = \left(\frac{\varepsilon}{R} \right) e^{-t/RC} = I_0 e^{-t/RC} \quad (7.6.13).$$

The coefficient in front of the exponential is equal to the initial current that flows in the circuit when the switch was closed at $t = 0$. The graph of current as a function of time is shown in Figure 7.6.4 below:

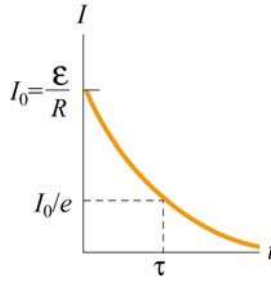

Figure 7.6.4 Current as a function of time during the charging process

The current in the charging circuit decreases exponentially in time, $I(t) = I_0 e^{-t/RC}$. This function is often written as $I(t) = I_0 e^{-t/\tau}$ where $\tau = RC$ is called the *time constant*. The SI units of τ are seconds, as can be seen from the dimensional analysis:

$$[\Omega][F] = ([V]/[A])([C]/[V]) = [C]/[A] = [C]/([C]/[s]) = [s]$$

The time constant τ is a measure of the decay time for the exponential function. This decay rate satisfies the following property:

$$I(t + \tau) = I(t) e^{-1} \quad (7.6.14)$$

which shows that after one time constant τ has elapsed, the current falls off by a factor of $e^{-1} = 0.368$, as indicated in Figure 7.6.4 above. Similarly, the voltage across the capacitor (Figure 7.6.5 below) can also be expressed in terms of the time constant τ :

$$V_C(t) = \epsilon(1 - e^{-t/\tau}) \quad (7.6.15)$$

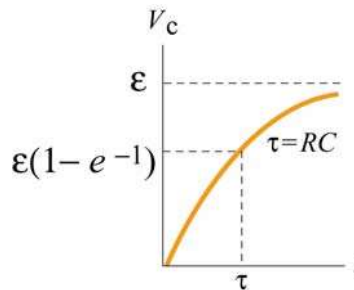

Figure 7.6.5 Voltage across capacitor as a function of time during the charging process.

Notice that initially at time $t = 0$, $V_C(t = 0) = 0$. After one time constant τ has elapsed, the potential difference across the capacitor plates has increased by a factor $(1 - e^{-1}) = 0.632$ of its final value:

$$V_C(\tau) = \epsilon(1 - e^{-1}) = 0.632 \epsilon \quad (7.6.16)$$

7.6.2 Discharging a Capacitor

Suppose initially the capacitor has been charged to some value Q . For $t < 0$, the switch is open and the potential difference across the capacitor is given by $V_C = Q/C$. On the other hand, the potential difference across the resistor is zero because there is no current flow, that is, $I = 0$. Now suppose at $t = 0$ the switch is closed (Figure 7.6.6). The capacitor will begin to discharge.

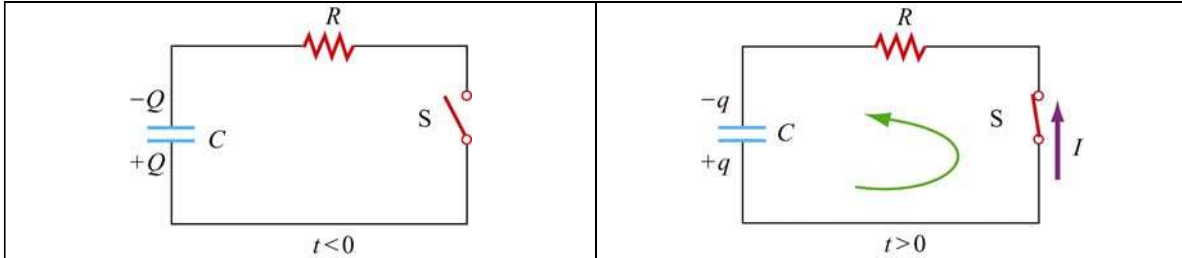

Figure 7.6.6 Discharging the RC circuit

The charged capacitor is now acting like a voltage source to drive current around the circuit. When the capacitor discharges (electrons flow from the negative plate through the wire to the positive plate), the voltage across the capacitor decreases. The capacitor is losing strength as a voltage source. Applying the Kirchhoff's loop rule by traversing the loop counterclockwise, the equation that describes the discharging process is given by

$$\frac{q}{C} - IR = 0 \quad (7.6.17)$$

The current that flows away from the positive plate is proportional to the charge on the plate,

$$I = -\frac{dq}{dt} \quad (7.6.18)$$

The negative sign in the equation is an indication that the rate of change of the charge is proportional to the *negative* of the charge on the capacitor. This is due to the fact that the charge on the positive plate is decreasing as more positive charges leave the positive plate. Thus, charge satisfies a first order differential equation:

$$\frac{q}{C} + R \frac{dq}{dt} = 0 \quad (7.6.19).$$

This equation can also be integrated by the method of separation of variables

$$\frac{dq}{q} = -\frac{1}{RC} dt \quad (7.6.20)$$

which yields

$$\int_Q^q \frac{dq'}{q'} = -\frac{1}{RC} \int_0^t dt' \quad \Rightarrow \quad \ln\left(\frac{q}{Q}\right) = -\frac{t}{RC} \quad (7.6.21)$$

or

$$\boxed{q(t) = Q e^{-t/RC}} \quad (7.6.22)$$

The voltage across the capacitor is then

$$V_C(t) = \frac{q(t)}{C} = \left(\frac{Q}{C}\right) e^{-t/RC} \quad (7.6.23)$$

A graph of voltage across the capacitor vs. time for the discharging capacitor is shown in Figure 7.6.7.

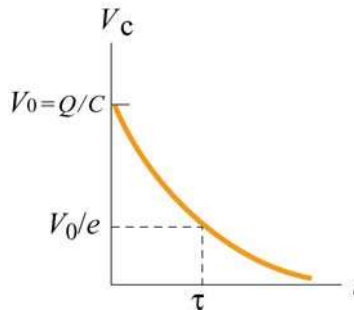

Figure 7.6.7 Voltage across the capacitor as a function of time for discharging capacitor.

The current also exponentially decays in the circuit as can be seen by differentiating the charge on the capacitor

$$I = -\frac{dq}{dt} = \left(\frac{Q}{RC}\right) e^{-t/RC} \quad (7.6.24)$$

A graph of the current flowing in the circuit as a function of time also has the same form as the voltage graph depicted in Figure 7.6.8.

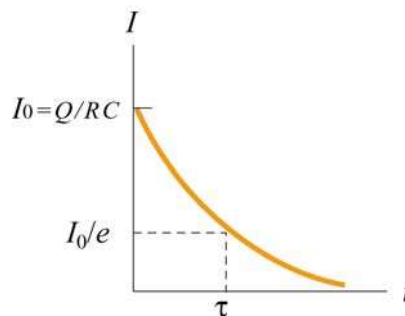

Figure 7.6.8 Current as a function of time for discharging capacitor.

7.7 Summary

- The equivalent resistance of a set of resistors connected in series:

$$R_{\text{eq}} = R_1 + R_2 + R_3 + \cdots = \sum_{i=1}^N R_i$$

- The equivalent resistance of a set of resistors connected in parallel:

$$\frac{1}{R_{\text{eq}}} = \frac{1}{R_1} + \frac{1}{R_2} + \frac{1}{R_3} + \cdots = \sum_{i=1}^N \frac{1}{R_i}$$

- **Kirchhoff's rules:**

(1) The sum of the currents flowing into a junction is equal to the sum of the currents flowing out of the junction:

$$\sum I_{\text{in}} = \sum I_{\text{out}}$$

(2) The algebraic sum of the changes in electric potential in a closed-circuit loop is zero.

$$\sum_{\text{closed loop}} \Delta V = 0$$

- In a charging capacitor, the charges and the current as a function of time are

$$q(t) = Q \left(1 - e^{-\frac{t}{RC}} \right), \quad I(t) = \left(\frac{\mathcal{E}}{R} \right) e^{-t/RC}$$

- In a discharging capacitor, the charges and the current as a function of time are

$$q(t) = Q e^{-t/RC}, \quad I(t) = \left(\frac{Q}{RC} \right) e^{-t/RC}$$

7.8 Problem-Solving Strategy: Applying Kirchhoff's Rules

In this chapter we have seen how Kirchhoff's rules can be used to analyze multiloop circuits. The steps are summarized below:

- (1) Draw a circuit diagram, and label all the quantities, both known and unknown. The number of unknown quantities is equal to the number of linearly independent equations we must look for.
- (2) Assign a direction to the current in each branch of the circuit. (If the actual direction is opposite to what you have assumed, your result at the end will be a negative number.)
- (3) Apply the junction rule to all but one of the junctions. (Applying the junction rule to the last junction will not yield any independent relationship among the currents.)
- (4) Apply the loop rule to the loops until the number of independent equations obtained is the same as the number of unknowns. For example, if there are three unknowns, then we must write down three linearly independent equations in order to have a unique solution.

Traverse the loops using the convention below for ΔV :

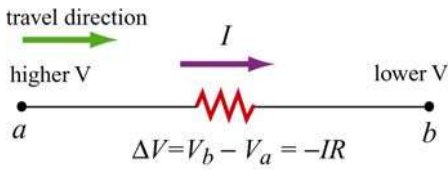
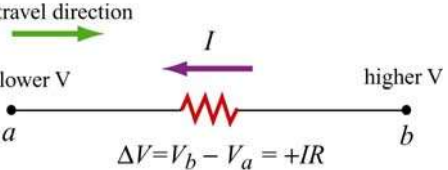
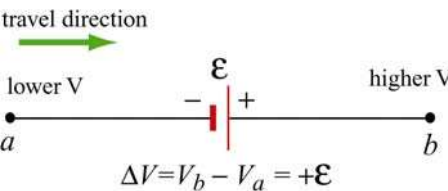
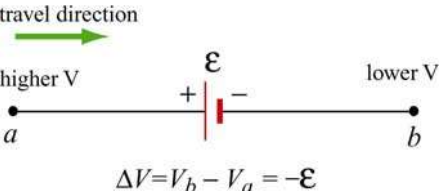
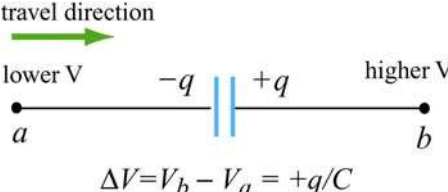
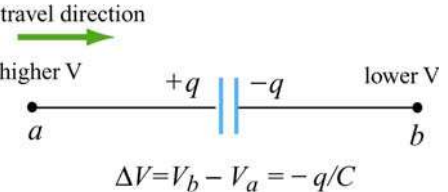
resistor	 <p>travel direction higher V a b lower V $\Delta V = V_b - V_a = -IR$</p>	 <p>travel direction lower V a b higher V $\Delta V = V_b - V_a = +IR$</p>
emf source	 <p>travel direction lower V a b higher V $\Delta V = V_b - V_a = +\epsilon$</p>	 <p>travel direction higher V a b lower V $\Delta V = V_b - V_a = -\epsilon$</p>
capacitor	 <p>travel direction lower V a b higher V $\Delta V = V_b - V_a = +q/C$</p>	 <p>travel direction higher V a b lower V $\Delta V = V_b - V_a = -q/C$</p>

The same equation is obtained whether the closed loop is traversed clockwise or counterclockwise. (The expressions actually differ by an overall negative sign. However, using the loop rule, we are led to $0 = -0$, and hence the same equation.)

- (5) Solve the simultaneous equations to obtain the solutions for the unknowns.

As an example of illustrating how the above procedures are executed, let's analyze the circuit shown in Figure 7.8.1.

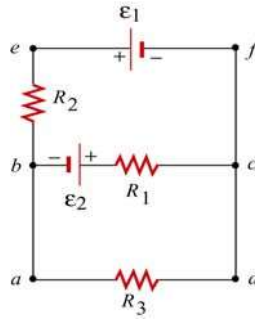

Figure 7.8.1 A multiloop circuit.

Suppose the emf sources ε_1 and ε_2 , and the resistances R_1 , R_2 and R_3 are all given, and we would like to find the currents through each resistor, using the methodology outlined above.

- (1) The unknown quantities are the three currents I_1 , I_2 and I_3 , associated with the three resistors. Therefore, to solve the system, we must look for three independent equations.
- (2) The directions for the three currents are arbitrarily assigned, as indicated in Figure 7.8.2.

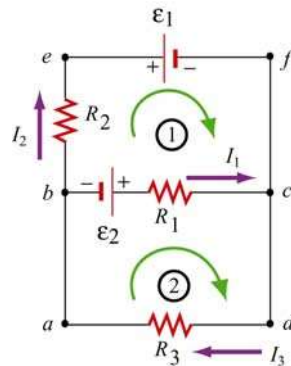

Figure 7.8.2

- (3) Applying Kirchhoff's current rule to junction b yields

$$I_1 + I_2 = I_3$$

since I_1 and I_2 are leaving the junction while I_3 is entering the junction. The same equation is obtained if we consider junction c .

- (4) The other two equations can be obtained by using the loop (voltage) rule, which states that the net potential difference across all elements in a closed circuit loop is zero. Traversing the first loop $befcb$ in the clockwise direction yields

$$-I_2 R_2 - \varepsilon_1 + I_1 R_1 - \varepsilon_2 = 0$$

Similarly, traversing the second loop $abcd$ clockwise gives

$$\varepsilon_2 - I_1 R_1 - I_3 R_3 = 0$$

Note however, that one may also consider the big loop $abefcd$. This leads to

$$-I_2 R_2 - \varepsilon_1 - I_3 R_3 = 0$$

However, the equation is not linearly independent of the other two loop equations since it is simply the sum of those equations.

(5) The solutions to the above three equations are given by, after tedious but straightforward algebra,

$$I_1 = \frac{\varepsilon_1 R_3 + \varepsilon_2 R_3 + \varepsilon_2 R_2}{R_1 R_2 + R_1 R_3 + R_2 R_3}$$

$$I_2 = -\frac{\varepsilon_1 R_1 + \varepsilon_1 R_3 + \varepsilon_2 R_3}{R_1 R_2 + R_1 R_3 + R_2 R_3}$$

$$I_3 = \frac{\varepsilon_2 R_2 - \varepsilon_1 R_1}{R_1 R_2 + R_1 R_3 + R_2 R_3}$$

Note that I_2 is a negative quantity. This simply indicates that the direction of I_2 is opposite of what we have initially assumed.

7.9 Solved Problems

7.9.1 Equivalent Resistance

Consider the circuit shown in Figure 7.9.1. For a given resistance R_0 , what must be the value of R_1 so that the equivalent resistance between the terminals is equal to R_0 ?

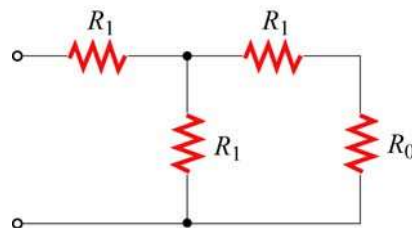

Figure 7.9.1

Solution:

The equivalent resistance, R' , due to the three resistors on the right is

$$\frac{1}{R'} = \frac{1}{R_1} + \frac{1}{R_0 + R_1} = \frac{R_0 + 2R_1}{R_1(R_0 + R_1)}$$

or

$$R' = \frac{R_1(R_0 + R_1)}{R_0 + 2R_1}$$

Since R' is in series with the fourth resistor R_1 , the equivalent resistance of the entire configuration becomes

$$R_{\text{eq}} = R_1 + \frac{R_1(R_0 + R_1)}{R_0 + 2R_1} = \frac{3R_1^2 + 2R_1R_0}{R_0 + 2R_1}$$

If $R_{\text{eq}} = R_0$, then

$$R_0(R_0 + 2R_1) = 3R_1^2 + 2R_1R_0 \Rightarrow R_0^2 = 3R_1^2$$

or

$$R_1 = \frac{R_0}{\sqrt{3}}$$

7.9.2 Variable Resistance

Show that, if a battery of fixed emf \mathcal{E} and internal resistance r is connected to a variable external resistance R , the maximum power is delivered to the external resistor when $R = r$.

Solution:

Using Kirchhoff's rule,

$$\mathcal{E} = I(R + r)$$

which implies

$$I = \frac{\mathcal{E}}{R + r}$$

The power dissipated is equal to

$$P = I^2 R = \frac{\mathcal{E}^2}{(R + r)^2} R$$

To find the value of R which gives out the maximum power, we differentiate P with respect to R and set the derivative equal to 0:

$$\frac{dP}{dR} = \varepsilon^2 \left[\frac{1}{(R+r)^2} - \frac{2R}{(R+r)^3} \right] = \varepsilon^2 \frac{r-R}{(R+r)^3} = 0$$

which implies

$$R = r$$

This is an example of “impedance matching,” in which the variable resistance R is adjusted so that the power delivered to it is maximized. The behavior of P as a function of R is depicted in Figure 7.9.2 below.

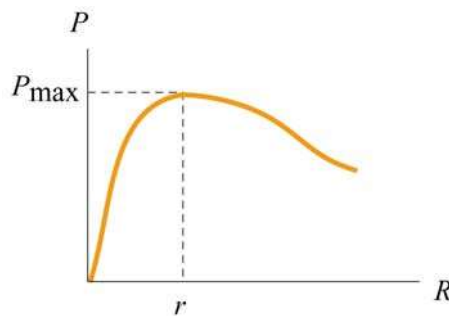

Figure 7.9.2

7.9.3 RC Circuit

In the circuit in figure 7.9.3, suppose the switch has been open for a very long time. At time $t = 0$, it is suddenly closed.

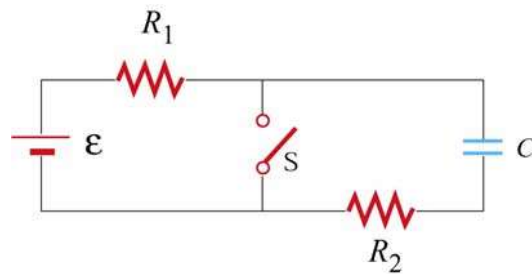

Figure 7.9.3

- What is the time constant before the switch is closed?
- What is the time constant after the switch is closed?
- Find the current through the switch as a function of time after the switch is closed.

Solutions:

(a) Before the switch is closed, the two resistors R_1 and R_2 are in series with the capacitor. Since the equivalent resistance is $R_{\text{eq}} = R_1 + R_2$, the time constant is given by

$$\tau = R_{\text{eq}}C = (R_1 + R_2)C$$

The amount of charge stored in the capacitor is

$$q(t) = C\varepsilon(1 - e^{-t/\tau})$$

(b) After the switch is closed, the closed loop on the right becomes a decaying RC circuit with time constant $\tau' = R_2C$. Charge begins to decay according to

$$q'(t) = C\varepsilon e^{-t/\tau'}$$

(c) The current passing through the switch consists of two sources: the steady current I_1 from the left circuit, and the decaying current I_2 from the RC circuit. The currents are given by

$$I_1 = \frac{\varepsilon}{R_1}$$
$$I'(t) = \frac{dq'}{dt} = -\left(\frac{C\varepsilon}{\tau'}\right)e^{-t/\tau'} = -\left(\frac{\varepsilon}{R_2}\right)e^{-t/R_2C}$$

The negative sign in $I'(t)$ indicates that the direction of flow is opposite of the charging process. Thus, since both I_1 and I' move downward across the switch, the total current is

$$I(t) = I_1 + I'(t) = \frac{\varepsilon}{R_1} + \left(\frac{\varepsilon}{R_2}\right)e^{-t/R_2C}$$

7.9.4 Parallel vs. Series Connections

Figure 7.9.4 show two resistors with resistances R_1 and R_2 connected in parallel and in series. The battery has a terminal voltage of ε .

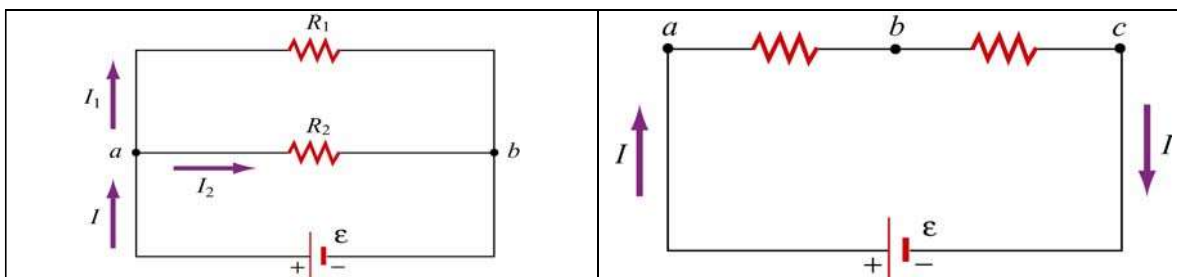

Figure 7.9.4

Suppose R_1 and R_2 are connected in parallel.

(a) Find the power delivered to each resistor.

(b) Show that the sum of the power used by each resistor is equal to the power supplied by the battery.

Suppose R_1 and R_2 are now connected in series.

(c) Find the power delivered to each resistor.

(d) Show that the sum of the power used by each resistor is equal to the power supplied by the battery.

(e) Which configuration, parallel or series, uses more power?

Solutions:

(a) When two resistors are connected in parallel, the current through each resistor is

$$I_1 = \frac{\mathcal{E}}{R_1}, \quad I_2 = \frac{\mathcal{E}}{R_2}$$

and the power delivered to each resistor is given by

$$P_1 = I_1^2 R_1 = \frac{\mathcal{E}^2}{R_1}, \quad P_2 = I_2^2 R_2 = \frac{\mathcal{E}^2}{R_2}$$

The results indicate that the smaller the resistance, the greater the amount of power delivered. If the loads are the light bulbs, then the one with smaller resistance will be brighter since more power is delivered to it.

(b) The total power delivered to the two resistors is

$$P_R = P_1 + P_2 = \frac{\mathcal{E}^2}{R_1} + \frac{\mathcal{E}^2}{R_2} = \frac{\mathcal{E}^2}{R_{\text{eq}}}$$

where

$$\frac{1}{R_{\text{eq}}} = \frac{1}{R_1} + \frac{1}{R_2} \Rightarrow R_{\text{eq}} = \frac{R_1 R_2}{R_1 + R_2}$$

is the equivalent resistance of the circuit. On the other hand, the total power supplied by the battery is $P_\varepsilon = I\varepsilon$, where $I = I_1 + I_2$, as seen from the figure. Thus,

$$P_\varepsilon = I_1\varepsilon + I_2\varepsilon = \left(\frac{\mathcal{E}}{R_1}\right)\varepsilon + \left(\frac{\mathcal{E}}{R_2}\right)\varepsilon = \frac{\mathcal{E}^2}{R_1} + \frac{\mathcal{E}^2}{R_2} = \frac{\mathcal{E}^2}{R_{\text{eq}}} = P_R$$

as required by energy conservation.

(c) When the two resistors are connected in series, the equivalent resistance becomes

$$R'_{\text{eq}} = R_1 + R_2$$

and the currents through the resistors are

$$I_1 = I_2 = I = \frac{\mathcal{E}}{R_1 + R_2}$$

Therefore, the power delivered to each resistor is

$$P_1 = I_1^2 R_1 = \left(\frac{\mathcal{E}}{R_1 + R_2}\right)^2 R_1, \quad P_2 = I_2^2 R_2 = \left(\frac{\mathcal{E}}{R_1 + R_2}\right)^2 R_2$$

Contrary to what we have seen in the parallel case, when connected in series, the greater the resistance, the greater the fraction of the power delivered. Once again, if the loads are light bulbs, the one with greater resistance will be brighter.

(d) The total power delivered to the resistors is

$$P'_R = P_1 + P_2 = \left(\frac{\mathcal{E}}{R_1 + R_2}\right)^2 R_1 + \left(\frac{\mathcal{E}}{R_1 + R_2}\right)^2 R_2 = \frac{\mathcal{E}^2}{R_1 + R_2} = \frac{\mathcal{E}^2}{R'_{\text{eq}}}$$

On the other hand, the power supplied by the battery is

$$P'_\varepsilon = I\varepsilon = \left(\frac{\varepsilon}{R_1 + R_2} \right) \varepsilon = \frac{\varepsilon^2}{R_1 + R_2} = \frac{\varepsilon^2}{R'_{\text{eq}}}$$

Again, we see that $P'_\varepsilon = P'_R$, as required by energy conservation.

(e) Comparing the results obtained in (b) and (d), we see that

$$P_\varepsilon = \frac{\varepsilon^2}{R_1} + \frac{\varepsilon^2}{R_2} > \frac{\varepsilon^2}{R_1 + R_2} = P'_\varepsilon$$

which means that the parallel connection uses more power. The equivalent resistance of two resistors connected in parallel is always smaller than that connected in series.

7.9.5 Resistor Network

Consider a cube which has identical resistors with resistance R along each edge, as shown in Figure 7.9.5.

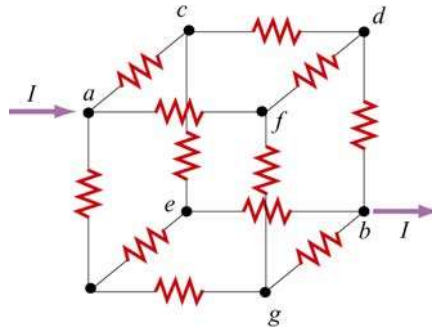

Figure 7.9.5 Resistor network

Show that the equivalent resistance between points a and b is $R_{\text{eq}} = 5R/6$.

Solution:

From symmetry arguments, the current which enters a must split evenly, with $I/3$ going to each branch. At the next junction, say c , $I/3$ must further split evenly with $I/6$ going through the two paths ce and cd . The current going through the resistor in db is the sum of the currents from fd and cd : $I/6 + I/6 = I/3$.

Thus, the potential difference between a and b can be obtained as

$$V_{ab} = V_{ac} + V_{cd} + V_{db} = \frac{I}{3}R + \frac{I}{6}R + \frac{I}{3}R = \frac{5}{6}IR$$

which shows that the equivalent resistance is

$$R_{\text{eq}} = \frac{5}{6}R$$

7.10 Conceptual Questions

1. Given three resistors of resistances R_1 , R_2 and R_3 , how should they be connected to (a) maximize (b) minimize the equivalent resistance?
2. Why do the headlights on the car become dim when the car is starting?
3. Does the resistor in an RC circuit affect the maximum amount of charge that can be stored in a capacitor? Explain.
4. Can one construct a circuit such that the potential difference across the terminals of the battery is zero? Explain.

7.11 Additional Problems

7.11.1 Resistive Circuits

Consider two identical batteries of emf \mathcal{E} and internal resistance r . They may be connected in series or in parallel and are used to establish a current in resistance R as shown in Figure 7.11.1.

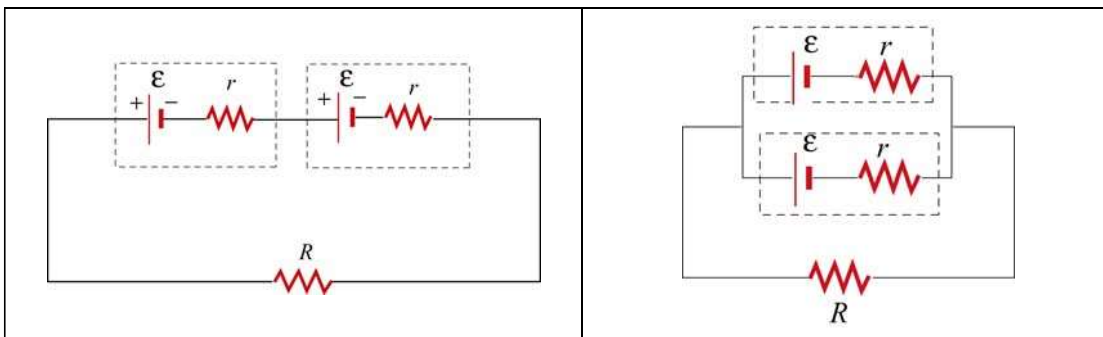

Figure 7.11.1 Two batteries connected in (a) series, and (b) parallel.

(a) Derive an expression for the current in R for the series connection shown in Figure 7.11.1(a). Be sure to indicate the current on the sketch (to establish a sign convention for the direction) and apply Kirchhoff's loop rule.

(b) Find the current for the parallel connection shown in Figure 7.11.1(b).

(c) For what relative values of r and R would the currents in the two configurations be the same?; be larger in Figure 7.11.1(a)?; be larger in 7.11.1(b)?

7.11.2 Multiloop Circuit

Consider the circuit shown in Figure 7.11.2. Neglecting the internal resistance of the batteries, calculate the currents through each of the three resistors.

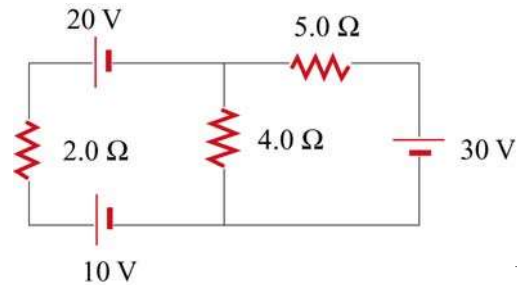

Figure 7.11.2

7.11.3 Power Delivered to the Resistors

Consider the circuit shown in Figure 7.11.3. Find the power delivered to each resistor.

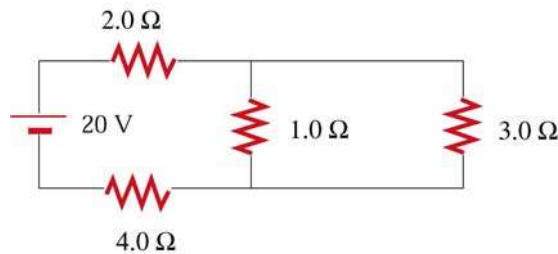

Figure 7.11.3

7.11.4 Resistor Network

Consider an infinite network of resistors of resistances R_0 and R_1 shown in Figure 7.11.4. Show that the equivalent resistance of this network is

$$R_{\text{eq}} = R_1 + \sqrt{R_1^2 + 2R_1R_0}$$

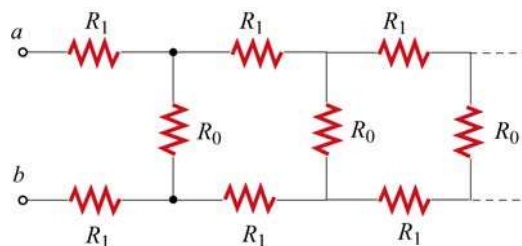

Figure 7.11.4

7.11.5 RC Circuit

Consider the circuit shown in Figure 7.11.5. Let $\varepsilon = 40 \text{ V}$, $R_1 = 8.0 \Omega$, $R_2 = 6.0 \Omega$, $R_3 = 4.0 \Omega$ and $C = 4.0 \mu\text{F}$. The capacitor is initially uncharged.

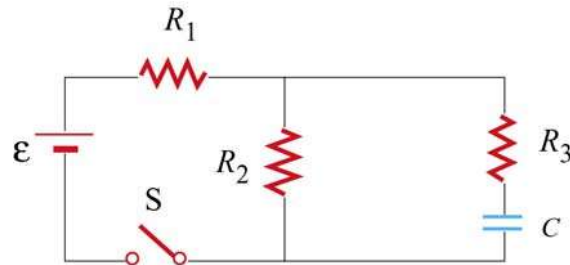

Figure 7.11.5

At $t = 0$, the switch is closed.

- (a) Find the current through each resistor immediately after the switch is closed.
- (b) Find the final charge on the capacitor.

7.11.6 Resistors in Series and Parallel

A circuit containing five resistors and a 12 V battery is shown in Figure 7.11.6. Find the potential drop across the 5Ω resistor. [Ans: 7.5 V].

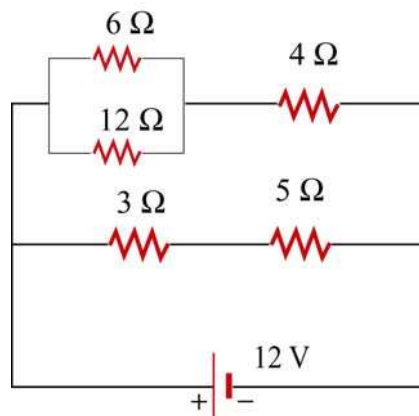

Figure 7.11.6

Chapter 8

Introduction to Magnetic Fields

8.1	Introduction.....	1
8.2	The Definition of a Magnetic Field	2
8.3	Magnetic Force on a Current-Carrying Wire.....	3
	Example 8.1: Magnetic Force on a Semi-Circular Loop.....	5
8.4	Torque on a Current Loop	7
	8.4.1 Magnetic force on a dipole	10
	Animation 8.1: Torques on a Dipole in a Constant Magnetic Field.....	11
8.5	Charged Particles in a Uniform Magnetic Field	12
	Animation 8.2: Charged Particle Moving in a Uniform Magnetic Field.....	14
8.6	Applications	14
	8.6.1 Velocity Selector.....	15
	8.6.2 Mass Spectrometer.....	16
8.7	Summary	17
8.8	Problem-Solving Tips	18
8.9	Solved Problems	19
	8.9.1 Rolling Rod.....	19
	8.9.2 Suspended Conducting Rod.....	20
	8.9.3 Charged Particles in Magnetic Field.....	21
	8.9.4 Bar Magnet in Non-Uniform Magnetic Field.....	22
8.10	Conceptual Questions	23
8.11	Additional Problems	23
	8.11.1 Force Exerted by a Magnetic Field.....	23
	8.11.2 Magnetic Force on a Current Carrying Wire	23
	8.11.3 Sliding Bar	24
	8.11.4 Particle Trajectory.....	25
	8.11.5 Particle Orbits in a Magnetic Field	25
	8.11.6 Force and Torque on a Current Loop.....	26
	8.11.7 Force on a Wire.....	26
	8.11.8 Levitating Wire	27

Introduction to Magnetic Fields

8.1 Introduction

We have seen that a charged object produces an electric field \vec{E} at all points in space. In a similar manner, a bar magnet is a source of a magnetic field \vec{B} . This can be readily demonstrated by moving a compass near the magnet. The compass needle will line up along the direction of the magnetic field produced by the magnet, as depicted in Figure 8.1.1.

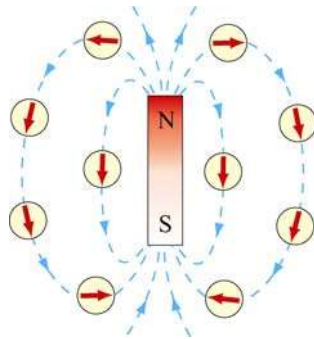

Figure 8.1.1 Magnetic field produced by a bar magnet

Notice that the bar magnet consists of two poles, which are designated as the north (N) and the south (S). Magnetic fields are strongest at the poles. The magnetic field lines leave from the north pole and enter the south pole. When holding two bar magnets close to each other, the like poles will repel each other while the opposite poles attract (Figure 8.1.2).

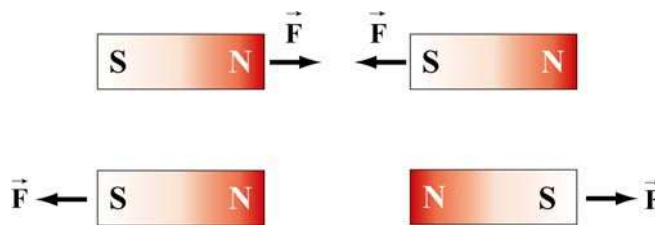

Figure 8.1.2 Magnets attracting and repelling

Unlike electric charges which can be isolated, the two magnetic poles always come in a pair. When you break the bar magnet, two new bar magnets are obtained, each with a north pole and a south pole (Figure 8.1.3). In other words, magnetic “monopoles” do not exist in isolation, although they are of theoretical interest.



Figure 8.1.3 Magnetic monopoles do not exist in isolation

How do we define the magnetic field $\vec{\mathbf{B}}$? In the case of an electric field $\vec{\mathbf{E}}$, we have already seen that the field is defined as the force per unit charge:

$$\vec{\mathbf{E}} = \frac{\vec{\mathbf{F}}_e}{q} \quad (8.1.1)$$

However, due to the absence of magnetic monopoles, $\vec{\mathbf{B}}$ must be defined in a different way.

8.2 The Definition of a Magnetic Field

To define the magnetic field at a point, consider a particle of charge q and moving at a velocity $\vec{\mathbf{v}}$. Experimentally we have the following observations:

- (1) The magnitude of the magnetic force $\vec{\mathbf{F}}_B$ exerted on the charged particle is proportional to both v and q .
- (2) The magnitude and direction of $\vec{\mathbf{F}}_B$ depends on $\vec{\mathbf{v}}$ and $\vec{\mathbf{B}}$.
- (3) The magnetic force $\vec{\mathbf{F}}_B$ vanishes when $\vec{\mathbf{v}}$ is parallel to $\vec{\mathbf{B}}$. However, when $\vec{\mathbf{v}}$ makes an angle θ with $\vec{\mathbf{B}}$, the direction of $\vec{\mathbf{F}}_B$ is perpendicular to the plane formed by $\vec{\mathbf{v}}$ and $\vec{\mathbf{B}}$, and the magnitude of $\vec{\mathbf{F}}_B$ is proportional to $\sin \theta$.
- (4) When the sign of the charge of the particle is switched from positive to negative (or vice versa), the direction of the magnetic force also reverses.

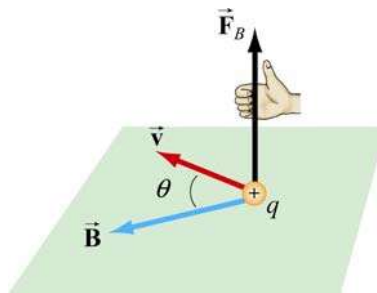

Figure 8.2.1 The direction of the magnetic force

The above observations can be summarized with the following equation:

$$\vec{\mathbf{F}}_B = q\vec{\mathbf{v}} \times \vec{\mathbf{B}} \quad (8.2.1)$$

The above expression can be taken as the working definition of the magnetic field at a point in space. The magnitude of \vec{F}_B is given by

$$F_B = |q| vB \sin \theta \quad (8.2.2)$$

The SI unit of magnetic field is the tesla (T):

$$1 \text{ tesla} = 1 \text{ T} = 1 \frac{\text{Newton}}{(\text{Coulomb})(\text{meter/second})} = 1 \frac{\text{N}}{\text{C} \cdot \text{m/s}} = 1 \frac{\text{N}}{\text{A} \cdot \text{m}}$$

Another commonly used non-SI unit for \vec{B} is the *gauss* (G), where $1\text{T} = 10^4 \text{ G}$.

Note that \vec{F}_B is always perpendicular to \vec{v} and \vec{B} , and cannot change the particle's speed v (and thus the kinetic energy). In other words, magnetic force cannot speed up or slow down a charged particle. Consequently, \vec{F}_B can do no work on the particle:

$$dW = \vec{F}_B \cdot d\vec{s} = q(\vec{v} \times \vec{B}) \cdot \vec{v} dt = q(\vec{v} \times \vec{v}) \cdot \vec{B} dt = 0 \quad (8.2.3)$$

The direction of \vec{v} , however, can be altered by the magnetic force, as we shall see below.

8.3 Magnetic Force on a Current-Carrying Wire

We have just seen that a charged particle moving through a magnetic field experiences a magnetic force \vec{F}_B . Since electric current consists of a collection of charged particles in motion, when placed in a magnetic field, a current-carrying wire will also experience a magnetic force.

Consider a long straight wire suspended in the region between the two magnetic poles. The magnetic field points out the page and is represented with dots (\bullet). It can be readily demonstrated that when a downward current passes through, the wire is deflected to the left. However, when the current is upward, the deflection is rightward, as shown in Figure 8.3.1.

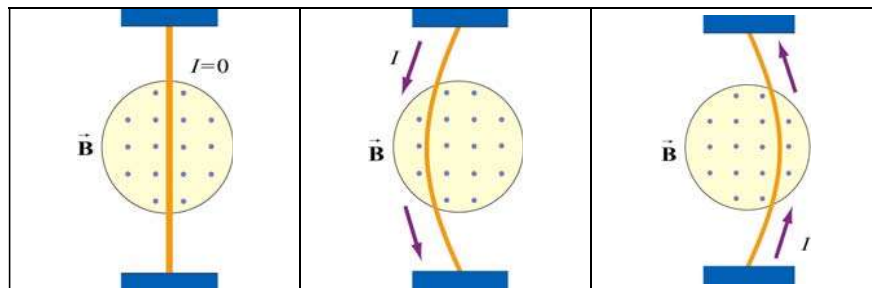

Figure 8.3.1 Deflection of current-carrying wire by magnetic force

To calculate the force exerted on the wire, consider a segment of wire of length ℓ and cross-sectional area A , as shown in Figure 8.3.2. The magnetic field points into the page, and is represented with crosses (X).

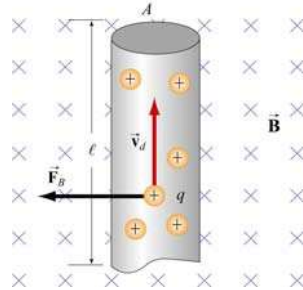

Figure 8.3.2 Magnetic force on a conducting wire

The charges move at an average drift velocity \vec{v}_d . Since the total amount of charge in this segment is $Q_{\text{tot}} = q(nA\ell)$, where n is the number of charges per unit volume, the total magnetic force on the segment is

$$\vec{F}_B = Q_{\text{tot}} \vec{v}_d \times \vec{B} = qnA\ell(\vec{v}_d \times \vec{B}) = I(\vec{\ell} \times \vec{B}) \quad (8.3.1)$$

where $I = nqv_d A$, and $\vec{\ell}$ is a *length vector* with a magnitude ℓ and directed along the direction of the electric current.

For a wire of arbitrary shape, the magnetic force can be obtained by summing over the forces acting on the small segments that make up the wire. Let the differential segment be denoted as $d\vec{s}$ (Figure 8.3.3).

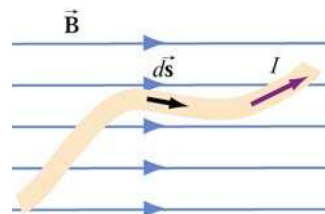

Figure 8.3.3 Current-carrying wire placed in a magnetic field

The magnetic force acting on the segment is

$$d\vec{F}_B = I d\vec{s} \times \vec{B} \quad (8.3.2)$$

Thus, the total force is

$$\vec{F}_B = I \int_a^b d\vec{s} \times \vec{B} \quad (8.3.3)$$

where a and b represent the endpoints of the wire.

As an example, consider a curved wire carrying a current I in a uniform magnetic field $\vec{\mathbf{B}}$, as shown in Figure 8.3.4.

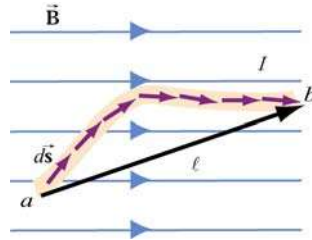

Figure 8.3.4 A curved wire carrying a current I .

Using Eq. (8.3.3), the magnetic force on the wire is given by

$$\vec{\mathbf{F}}_B = I \left(\int_a^b d\vec{\mathbf{s}} \right) \times \vec{\mathbf{B}} = I \vec{\mathbf{l}} \times \vec{\mathbf{B}} \quad (8.3.4)$$

where $\vec{\mathbf{l}}$ is the length vector directed from a to b . However, if the wire forms a closed loop of arbitrary shape (Figure 8.3.5), then the force on the loop becomes

$$\vec{\mathbf{F}}_B = I \left(\oint d\vec{\mathbf{s}} \right) \times \vec{\mathbf{B}} \quad (8.3.5)$$

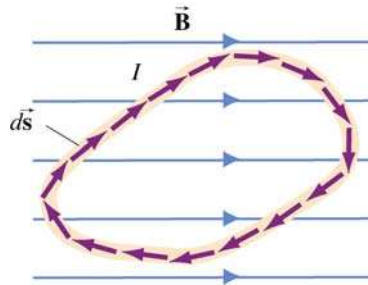

Figure 8.3.5 A closed loop carrying a current I in a uniform magnetic field.

Since the set of differential length elements $d\vec{\mathbf{s}}$ form a closed polygon, and their vector sum is zero, i.e., $\oint d\vec{\mathbf{s}} = 0$. The net magnetic force on a closed loop is $\vec{\mathbf{F}}_B = \vec{\mathbf{0}}$.

Example 8.1: Magnetic Force on a Semi-Circular Loop

Consider a closed semi-circular loop lying in the xy plane carrying a current I in the counterclockwise direction, as shown in Figure 8.3.6.

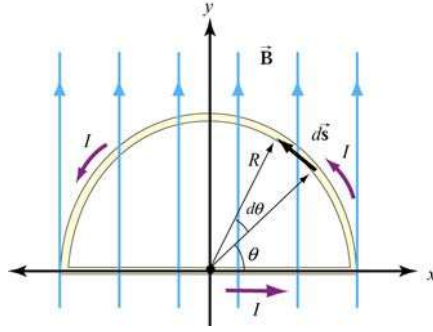

Figure 8.3.6 Semi-circular loop carrying a current I

A uniform magnetic field pointing in the $+y$ direction is applied. Find the magnetic force acting on the straight segment and the semicircular arc.

Solution:

Let $\vec{B} = B\hat{j}$ and \vec{F}_1 and \vec{F}_2 the forces acting on the straight segment and the semicircular parts, respectively. Using Eq. (8.3.3) and noting that the length of the straight segment is $2R$, the magnetic force is

$$\vec{F}_1 = I(2R\hat{i}) \times (B\hat{j}) = 2IRB\hat{k}$$

where \hat{k} is directed out of the page.

To evaluate \vec{F}_2 , we first note that the differential length element $d\vec{s}$ on the semicircle can be written as $d\vec{s} = ds\hat{\theta} = Rd\theta(-\sin\theta\hat{i} + \cos\theta\hat{j})$. The force acting on the length element $d\vec{s}$ is

$$d\vec{F}_2 = Id\vec{s} \times \vec{B} = IRd\theta(-\sin\theta\hat{i} + \cos\theta\hat{j}) \times (B\hat{j}) = -IBR\sin\theta d\theta\hat{k}$$

Here we see that $d\vec{F}_2$ points into the page. Integrating over the entire semi-circular arc, we have

$$\vec{F}_2 = -IBR\hat{k} \int_0^\pi \sin\theta d\theta = -2IBR\hat{k}$$

Thus, the net force acting on the semi-circular wire is

$$\vec{F}_{\text{net}} = \vec{F}_1 + \vec{F}_2 = \vec{0}$$

This is consistent from our previous claim that the net magnetic force acting on a closed current-carrying loop must be zero.

8.4 Torque on a Current Loop

What happens when we place a rectangular loop carrying a current I in the xy plane and switch on a uniform magnetic field $\vec{\mathbf{B}} = B\hat{\mathbf{i}}$ which runs parallel to the plane of the loop, as shown in Figure 8.4.1(a)?

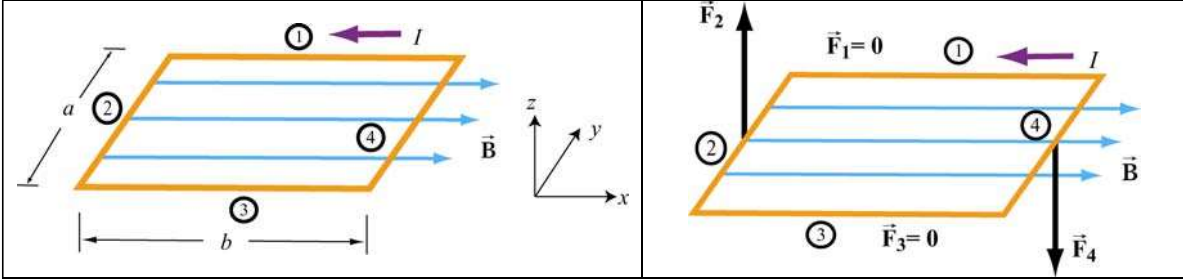

Figure 8.4.1 (a) A rectangular current loop placed in a uniform magnetic field. (b) The magnetic forces acting on sides 2 and 4.

From Eq. 8.4.1, we see the magnetic forces acting on sides 1 and 3 vanish because the length vectors $\vec{\ell}_1 = -b\hat{\mathbf{i}}$ and $\vec{\ell}_3 = b\hat{\mathbf{i}}$ are parallel and anti-parallel to $\vec{\mathbf{B}}$ and their cross products vanish. On the other hand, the magnetic forces acting on segments 2 and 4 are non-vanishing:

$$\begin{cases} \vec{\mathbf{F}}_2 = I(-a\hat{\mathbf{j}}) \times (B\hat{\mathbf{i}}) = IaB\hat{\mathbf{k}} \\ \vec{\mathbf{F}}_4 = I(a\hat{\mathbf{j}}) \times (B\hat{\mathbf{i}}) = -IaB\hat{\mathbf{k}} \end{cases} \quad (8.4.1)$$

with $\vec{\mathbf{F}}_2$ pointing out of the page and $\vec{\mathbf{F}}_4$ into the page. Thus, the net force on the rectangular loop is

$$\vec{\mathbf{F}}_{\text{net}} = \vec{\mathbf{F}}_1 + \vec{\mathbf{F}}_2 + \vec{\mathbf{F}}_3 + \vec{\mathbf{F}}_4 = \vec{\mathbf{0}} \quad (8.4.2)$$

as expected. Even though the net force on the loop vanishes, the forces $\vec{\mathbf{F}}_2$ and $\vec{\mathbf{F}}_4$ will produce a torque which causes the loop to rotate about the y -axis (Figure 8.4.2). The torque with respect to the center of the loop is

$$\begin{aligned} \vec{\tau} &= \left(-\frac{b}{2}\hat{\mathbf{i}}\right) \times \vec{\mathbf{F}}_2 + \left(\frac{b}{2}\hat{\mathbf{i}}\right) \times \vec{\mathbf{F}}_4 = \left(-\frac{b}{2}\hat{\mathbf{i}}\right) \times (IaB\hat{\mathbf{k}}) + \left(\frac{b}{2}\hat{\mathbf{i}}\right) \times (-IaB\hat{\mathbf{k}}) \\ &= \left(\frac{IabB}{2} + \frac{IabB}{2}\right)\hat{\mathbf{j}} = IabB\hat{\mathbf{j}} = IAB\hat{\mathbf{j}} \end{aligned} \quad (8.4.3)$$

where $A = ab$ represents the area of the loop and the positive sign indicates that the rotation is clockwise about the y -axis. It is convenient to introduce the area vector $\vec{A} = A\hat{n}$ where \hat{n} is a unit vector in the direction normal to the plane of the loop. The direction of the positive sense of \hat{n} is set by the conventional right-hand rule. In our case, we have $\hat{n} = +\hat{k}$. The above expression for torque can then be rewritten as

$$\vec{\tau} = I\vec{A} \times \vec{B} \quad (8.4.4)$$

Notice that the magnitude of the torque is at a maximum when \vec{B} is parallel to the plane of the loop (or perpendicular to \vec{A}).

Consider now the more general situation where the loop (or the area vector \vec{A}) makes an angle θ with respect to the magnetic field.

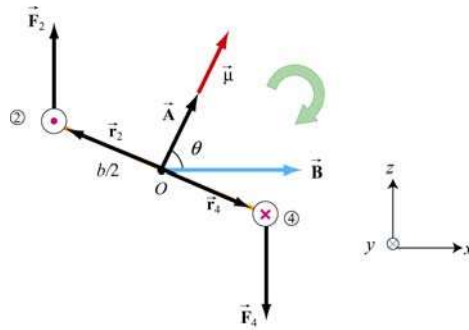

Figure 8.4.2 Rotation of a rectangular current loop

From Figure 8.4.2, the lever arms can be expressed as:

$$\vec{r}_2 = \frac{b}{2}(-\sin\theta\hat{i} + \cos\theta\hat{k}) = -\vec{r}_4 \quad (8.4.5)$$

and the net torque becomes

$$\begin{aligned} \vec{\tau} &= \vec{r}_2 \times \vec{F}_2 + \vec{r}_4 \times \vec{F}_4 = 2\vec{r}_2 \times \vec{F}_2 = 2 \cdot \frac{b}{2}(-\sin\theta\hat{i} + \cos\theta\hat{k}) \times (IaB\hat{k}) \\ &= IabB \sin\theta \hat{j} = I\vec{A} \times \vec{B} \end{aligned} \quad (8.4.6)$$

For a loop consisting of N turns, the magnitude of the torque is

$$\tau = NIAB \sin\theta \quad (8.4.7)$$

The quantity $NI\vec{A}$ is called the magnetic dipole moment $\vec{\mu}$:

$$\boxed{\vec{\mu} = NI\vec{A}} \quad (8.4.8)$$

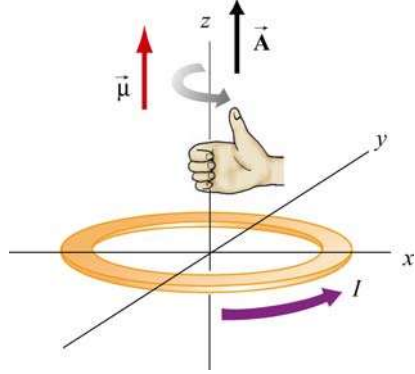

Figure 8.4.3 Right-hand rule for determining the direction of $\vec{\mu}$

The direction of $\vec{\mu}$ is the same as the area vector \vec{A} (perpendicular to the plane of the loop) and is determined by the right-hand rule (Figure 8.4.3). The SI unit for the magnetic dipole moment is ampere-meter² ($\text{A} \cdot \text{m}^2$). Using the expression for $\vec{\mu}$, the torque exerted on a current-carrying loop can be rewritten as

$$\boxed{\vec{\tau} = \vec{\mu} \times \vec{B}} \quad (8.4.9)$$

The above equation is analogous to $\vec{\tau} = \vec{p} \times \vec{E}$ in Eq. (2.8.3), the torque exerted on an electric dipole moment \vec{p} in the presence of an electric field \vec{E} . Recalling that the potential energy for an electric dipole is $U = -\vec{p} \cdot \vec{E}$ [see Eq. (2.8.7)], a similar form is expected for the magnetic case. The work done by an external agent to rotate the magnetic dipole from an angle θ_0 to θ is given by

$$\begin{aligned} W_{\text{ext}} &= \int_{\theta_0}^{\theta} \tau d\theta' = \int_{\theta_0}^{\theta} (\mu B \sin \theta') d\theta' = \mu B (\cos \theta_0 - \cos \theta) \\ &= \Delta U = U - U_0 \end{aligned} \quad (8.4.10)$$

Once again, $W_{\text{ext}} = -W$, where W is the work done by the magnetic field. Choosing $U_0 = 0$ at $\theta_0 = \pi/2$, the dipole in the presence of an external field then has a potential energy of

$$U = -\mu B \cos \theta = -\vec{\mu} \cdot \vec{B} \quad (8.4.11)$$

The configuration is at a stable equilibrium when $\vec{\mu}$ is aligned parallel to \vec{B} , making U a minimum with $U_{\text{min}} = -\mu B$. On the other hand, when $\vec{\mu}$ and \vec{B} are anti-parallel, $U_{\text{max}} = +\mu B$ is a maximum and the system is unstable.

8.4.1 Magnetic force on a dipole

As we have shown above, the force experienced by a current-carrying rectangular loop (i.e., a magnetic dipole) placed in a uniform magnetic field is zero. What happens if the magnetic field is non-uniform? In this case, there will be a net force acting on the dipole.

Consider the situation where a small dipole $\vec{\mu}$ is placed along the symmetric axis of a bar magnet, as shown in Figure 8.4.4.

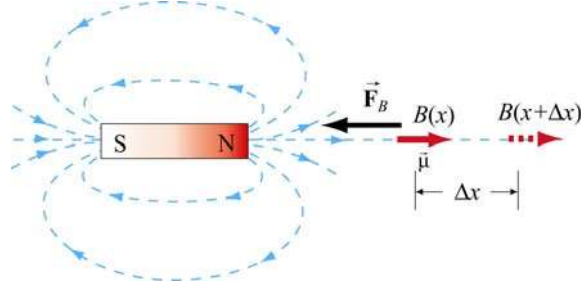

Figure 8.4.4 A magnetic dipole near a bar magnet.

The dipole experiences an attractive force by the bar magnet whose magnetic field is non-uniform in space. Thus, an external force must be applied to move the dipole to the right. The amount of force F_{ext} exerted by an external agent to move the dipole by a distance Δx is given by

$$F_{\text{ext}} \Delta x = W_{\text{ext}} = \Delta U = -\mu B(x + \Delta x) + \mu B(x) = -\mu [B(x + \Delta x) - B(x)] \quad (8.4.12)$$

where we have used Eq. (8.4.11). For small Δx , the external force may be obtained as

$$F_{\text{ext}} = -\mu \frac{[B(x + \Delta x) - B(x)]}{\Delta x} = -\mu \frac{dB}{dx} \quad (8.4.13)$$

which is a positive quantity since $dB/dx < 0$, i.e., the magnetic field decreases with increasing x . This is precisely the force needed to overcome the attractive force due to the bar magnet. Thus, we have

$$F_B = \mu \frac{dB}{dx} = \frac{d}{dx} (\vec{\mu} \cdot \vec{B}) \quad (8.4.14)$$

More generally, the magnetic force experienced by a dipole $\vec{\mu}$ placed in a non-uniform magnetic field \vec{B} can be written as

$$\vec{F}_B = \nabla (\vec{\mu} \cdot \vec{B}) \quad (8.4.15)$$

where

$$\nabla = \frac{\partial}{\partial x} \hat{\mathbf{i}} + \frac{\partial}{\partial y} \hat{\mathbf{j}} + \frac{\partial}{\partial z} \hat{\mathbf{k}} \quad (8.4.16)$$

is the gradient operator.

Animation 8.1: Torques on a Dipole in a Constant Magnetic Field

“...To understand this point, we have to consider that a [compass] needle vibrates by gathering upon itself, because of its magnetic condition and polarity, a certain amount of the lines of force, which would otherwise traverse the space about it...”

Michael Faraday [1855]

Consider a magnetic dipole in a constant background field. Historically, we note that Faraday understood the oscillations of a compass needle in exactly the way we describe here. We show in Figure 8.4.5 a magnetic dipole in a “dip needle” oscillating in the magnetic field of the Earth, at a latitude approximately the same as that of Boston. The magnetic field of the Earth is predominantly downward and northward at these Northern latitudes, as the visualization indicates.

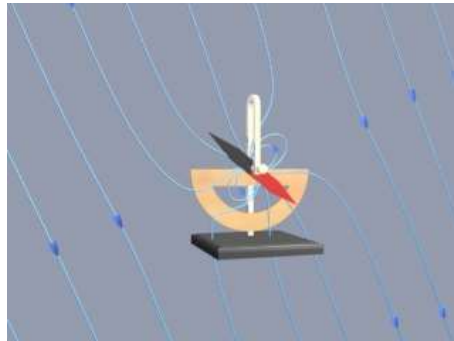

Figure 8.4.5 A magnetic dipole in the form of a dip needle oscillates in the magnetic field of the Earth.

To explain what is going on in this visualization, suppose that the magnetic dipole vector is initially along the direction of the earth’s field and rotating clockwise. As the dipole rotates, the magnetic field lines are compressed and stretched. The tensions and pressures associated with this field line stretching and compression results in an electromagnetic torque on the dipole that slows its clockwise rotation. Eventually the dipole comes to rest. But the counterclockwise torque still exists, and the dipole then starts to rotate counterclockwise, passing back through being parallel to the Earth’s field again (where the torque goes to zero), and overshooting.

As the dipole continues to rotate counterclockwise, the magnetic field lines are now compressed and stretched in the opposite sense. The electromagnetic torque has reversed sign, now slowing the dipole in its counterclockwise rotation. Eventually the dipole will come to rest, start rotating clockwise once more, and pass back through being parallel to

the field, as in the beginning. If there is no damping in the system, this motion continues indefinitely.

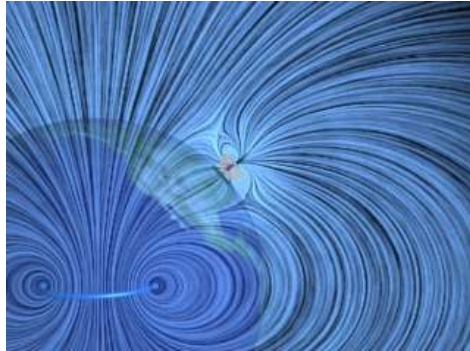

Figure 8.4.6 A magnetic dipole in the form of a dip needle rotates oscillates in the magnetic field of the Earth. We show the currents that produce the earth's field in this visualization.

What about the conservation of angular momentum in this situation? Figure 8.4.6 shows a global picture of the field lines of the dip needle and the field lines of the Earth, which are generated deep in the core of the Earth. If you examine the stresses transmitted between the Earth and the dip needle in this visualization, you can convince yourself that any clockwise torque on the dip needle is accompanied by a counterclockwise torque on the currents producing the earth's magnetic field. Angular momentum is conserved by the exchange of equal and opposite amounts of angular momentum between the compass and the currents in the Earth's core.

8.5 Charged Particles in a Uniform Magnetic Field

If a particle of mass m moves in a circle of radius r at a constant speed v , what acts on the particle is a radial force of magnitude $F = mv^2/r$ that always points toward the center and is perpendicular to the velocity of the particle.

In Section 8.2, we have also shown that the magnetic force \vec{F}_B always points in the direction perpendicular to the velocity \vec{v} of the charged particle and the magnetic field \vec{B} . Since \vec{F}_B can do no work, it can only change the direction of \vec{v} but not its magnitude. What would happen if a charged particle moves through a uniform magnetic field \vec{B} with its initial velocity \vec{v} at a right angle to \vec{B} ? For simplicity, let the charge be $+q$ and the direction of \vec{B} be into the page. It turns out that \vec{F}_B will play the role of a centripetal force and the charged particle will move in a circular path in a counterclockwise direction, as shown in Figure 8.5.1.

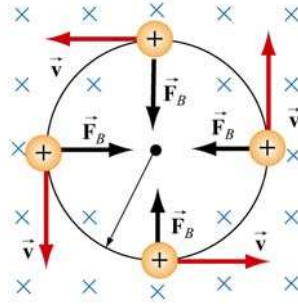

Figure 8.5.1 Path of a charge particle moving in a uniform \vec{B} field with velocity \vec{v} initially perpendicular to \vec{B} .

With

$$qvB = \frac{mv^2}{r} \quad (8.5.1)$$

the radius of the circle is found to be

$$r = \frac{mv}{qB} \quad (8.5.2)$$

The period T (time required for one complete revolution) is given by

$$T = \frac{2\pi r}{v} = \frac{2\pi}{v} \frac{mv}{qB} = \frac{2\pi m}{qB} \quad (8.5.3)$$

Similarly, the angular speed (cyclotron frequency) ω of the particle can be obtained as

$$\omega = 2\pi f = \frac{v}{r} = \frac{qB}{m} \quad (8.5.4)$$

If the initial velocity of the charged particle has a component parallel to the magnetic field \vec{B} , instead of a circle, the resulting trajectory will be a helical path, as shown in Figure 8.5.2:

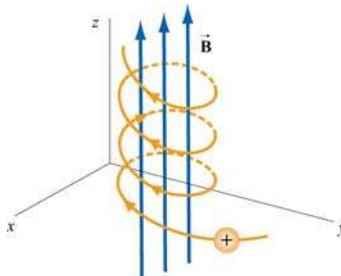

Figure 8.5.2 Helical path of a charged particle in an external magnetic field. The velocity of the particle has a non-zero component along the direction of \vec{B} .

Animation 8.2: Charged Particle Moving in a Uniform Magnetic Field

Figure 8.5.3 shows a charge moving toward a region where the magnetic field is vertically upward. When the charge enters the region where the external magnetic field is non-zero, it is deflected in a direction perpendicular to that field and to its velocity as it enters the field. This causes the charge to move in an arc that is a segment of a circle, until the charge exits the region where the external magnetic field is non-zero. We show in the animation the total magnetic field which is the sum of the external magnetic field and the magnetic field of the moving charge (to be shown in Chapter 9):

$$\vec{\mathbf{B}} = \frac{\mu_0}{4\pi} \frac{q\vec{\mathbf{v}} \times \hat{\mathbf{r}}}{r^2} \quad (8.5.5)$$

The bulging of that field on the side opposite the direction in which the particle is pushed is due to the buildup of magnetic pressure on that side. It is this pressure that causes the charge to move in a circle.

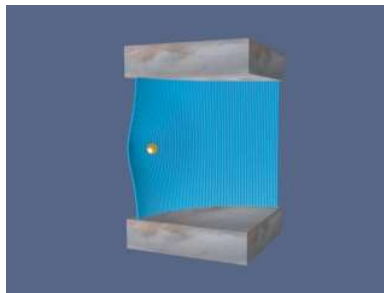

Figure 8.5.3 A charged particle moves in a magnetic field that is non-zero over the pie-shaped region shown. The external field is upward.

Finally, consider momentum conservation. The moving charge in the animation of Figure 8.5.3 changes its direction of motion by ninety degrees over the course of the animation. How do we conserve momentum in this process? Momentum is conserved because momentum is transmitted by the field *from* the moving charge *to* the currents that are generating the constant external field. This is plausible given the field configuration shown in Figure 8.5.3. The magnetic field stress, which *pushes* the moving charge sideways, is accompanied by a tension *pulling* the current source in the opposite direction. To see this, look closely at the field stresses where the external field lines enter the region where the currents that produce them are hidden, and remember that the magnetic field acts as if it were exerting a tension parallel to itself. The momentum loss by the moving charge is transmitted to the hidden currents producing the constant field in this manner.

8.6 Applications

There are many applications involving charged particles moving through a uniform magnetic field.

8.6.1 Velocity Selector

In the presence of both electric field \vec{E} and magnetic field \vec{B} , the total force on a charged particle is

$$\vec{F} = q(\vec{E} + \vec{v} \times \vec{B}) \quad (8.6.1)$$

This is known as the Lorentz force. By combining the two fields, particles which move with a certain velocity can be selected. This was the principle used by J. J. Thomson to measure the charge-to-mass ratio of the electrons. In Figure 8.6.1 the schematic diagram of Thomson's apparatus is depicted.

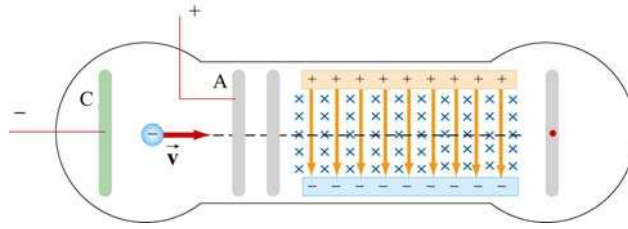

Figure 8.6.1 Thomson's apparatus

The electrons with charge $q = -e$ and mass m are emitted from the cathode C and then accelerated toward slit A. Let the potential difference between A and C be $V_A - V_C = \Delta V$. The change in potential energy is equal to the external work done in accelerating the electrons: $\Delta U = W_{\text{ext}} = q\Delta V = -e\Delta V$. By energy conservation, the kinetic energy gained is $\Delta K = -\Delta U = mv^2/2$. Thus, the speed of the electrons is given by

$$v = \sqrt{\frac{2e\Delta V}{m}} \quad (8.6.2)$$

If the electrons further pass through a region where there exists a downward uniform electric field, the electrons, being negatively charged, will be deflected upward. However, if in addition to the electric field, a magnetic field directed into the page is also applied, then the electrons will experience an additional downward magnetic force $-e\vec{v} \times \vec{B}$. When the two forces exactly cancel, the electrons will move in a straight path. From Eq. 8.6.1, we see that when the condition for the cancellation of the two forces is given by $eE = evB$, which implies

$$v = \frac{E}{B} \quad (8.6.3)$$

In other words, only those particles with speed $v = E/B$ will be able to move in a straight line. Combining the two equations, we obtain

$$\frac{e}{m} = \frac{E^2}{2(\Delta V)B^2} \quad (8.6.4)$$

By measuring E , ΔV and B , the charge-to-mass ratio can be readily determined. The most precise measurement to date is $e/m = 1.758820174(71) \times 10^{11}$ C/kg.

8.6.2 Mass Spectrometer

Various methods can be used to measure the mass of an atom. One possibility is through the use of a mass spectrometer. The basic feature of a *Bainbridge* mass spectrometer is illustrated in Figure 8.6.2. A particle carrying a charge $+q$ is first sent through a velocity selector.

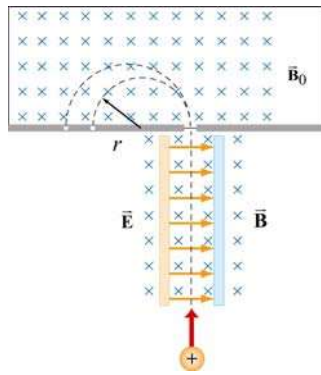

Figure 8.6.2 A Bainbridge mass spectrometer

The applied electric and magnetic fields satisfy the relation $E = vB$ so that the trajectory of the particle is a straight line. Upon entering a region where a second magnetic field \vec{B}_0 pointing into the page has been applied, the particle will move in a circular path with radius r and eventually strike the photographic plate. Using Eq. 8.5.2, we have

$$r = \frac{mv}{qB_0} \quad (8.6.5)$$

Since $v = E/B$, the mass of the particle can be written as

$$m = \frac{qB_0r}{v} = \frac{qB_0Br}{E} \quad (8.6.6)$$

8.7 Summary

- The **magnetic force** acting on a charge q traveling at a velocity \vec{v} in a magnetic field \vec{B} is given by

$$\vec{F}_B = q\vec{v} \times \vec{B}$$

- The magnetic force acting on a wire of length $\vec{\ell}$ carrying a steady current I in a magnetic field \vec{B} is

$$\vec{F}_B = I\vec{\ell} \times \vec{B}$$

- The magnetic force $d\vec{F}_B$ generated by a small portion of current I of length $d\vec{s}$ in a magnetic field \vec{B} is

$$d\vec{F}_B = I d\vec{s} \times \vec{B}$$

- The **torque** $\vec{\tau}$ acting on a close loop of wire of area A carrying a current I in a uniform magnetic field \vec{B} is

$$\vec{\tau} = I\vec{A} \times \vec{B}$$

where \vec{A} is a vector which has a magnitude of A and a direction perpendicular to the loop.

- The **magnetic dipole moment** of a closed loop of wire of area A carrying a current I is given by

$$\vec{\mu} = I\vec{A}$$

- The torque exerted on a magnetic dipole $\vec{\mu}$ placed in an external magnetic field \vec{B} is

$$\vec{\tau} = \vec{\mu} \times \vec{B}$$

- The potential energy of a magnetic dipole placed in a magnetic field is

$$U = -\vec{\mu} \cdot \vec{B}$$

- If a particle of charge q and mass m enters a magnetic field of magnitude B with a velocity \vec{v} perpendicular to the magnetic field lines, the radius of the circular path that the particle follows is given by

$$r = \frac{mv}{|q|B}$$

and the angular speed of the particle is

$$\omega = \frac{|q|B}{m}$$

8.8 Problem-Solving Tips

In this Chapter, we have shown that in the presence of both magnetic field \vec{B} and the electric field \vec{E} , the total force acting on a moving particle with charge q is $\vec{F} = \vec{F}_e + \vec{F}_B = q(\vec{E} + \vec{v} \times \vec{B})$, where \vec{v} is the velocity of the particle. The direction of \vec{F}_B involves the cross product of \vec{v} and \vec{B} , based on the right-hand rule. In Cartesian coordinates, the unit vectors are \hat{i} , \hat{j} and \hat{k} which satisfy the following properties:

$$\hat{i} \times \hat{j} = \hat{k}, \quad \hat{j} \times \hat{k} = \hat{i}, \quad \hat{k} \times \hat{i} = \hat{j}$$

$$\hat{j} \times \hat{i} = -\hat{k}, \quad \hat{k} \times \hat{j} = -\hat{i}, \quad \hat{i} \times \hat{k} = -\hat{j}$$

$$\hat{i} \times \hat{i} = \hat{j} \times \hat{j} = \hat{k} \times \hat{k} = 0$$

For $\vec{v} = v_x \hat{i} + v_y \hat{j} + v_z \hat{k}$ and $\vec{B} = B_x \hat{i} + B_y \hat{j} + B_z \hat{k}$, the cross product may be obtained as

$$\vec{v} \times \vec{B} = \begin{vmatrix} \hat{i} & \hat{j} & \hat{k} \\ v_x & v_y & v_z \\ B_x & B_y & B_z \end{vmatrix} = (v_y B_z - v_z B_y) \hat{i} + (v_z B_x - v_x B_z) \hat{j} + (v_x B_y - v_y B_x) \hat{k}$$

If only the magnetic field is present, and \vec{v} is perpendicular to \vec{B} , then the trajectory is a circle with a radius $r = mv / |q|B$, and an angular speed $\omega = |q|B / m$.

When dealing with a more complicated case, it is useful to work with individual force components. For example,

$$F_x = ma_x = qE_x + q(v_y B_z - v_z B_y)$$

8.9 Solved Problems

8.9.1 Rolling Rod

A rod with a mass m and a radius R is mounted on two parallel rails of length a separated by a distance ℓ , as shown in the Figure 8.9.1. The rod carries a current I and rolls without slipping along the rails which are placed in a uniform magnetic field $\vec{\mathbf{B}}$ directed into the page. If the rod is initially at rest, what is its speed as it leaves the rails?

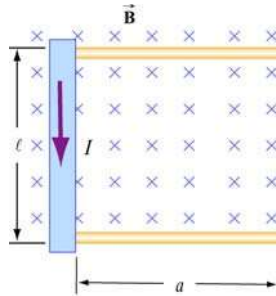
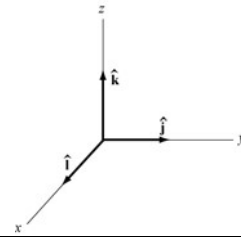

Figure 8.9.1 Rolling rod in uniform magnetic field

Solution:

Using the coordinate system shown on the right, the magnetic force acting on the rod is given by

$$\vec{\mathbf{F}}_B = I\vec{\ell} \times \vec{\mathbf{B}} = I(\ell\hat{\mathbf{i}}) \times (-B\hat{\mathbf{k}}) = I\ell B\hat{\mathbf{j}} \quad (8.9.1)$$



The total work done by the magnetic force on the rod as it moves through the region is

$$W = \int \vec{\mathbf{F}}_B \cdot d\vec{\mathbf{s}} = F_B a = (I\ell B)a \quad (8.9.2)$$

By the work-energy theorem, W must be equal to the change in kinetic energy:

$$\Delta K = \frac{1}{2}mv^2 + \frac{1}{2}I\omega^2 \quad (8.9.3)$$

where both translation and rolling are involved. Since the moment of inertia of the rod is given by $I = mR^2/2$, and the condition of rolling with slipping implies $\omega = v/R$, we have

$$I\ell Ba = \frac{1}{2}mv^2 + \frac{1}{2}\left(\frac{mR^2}{2}\right)\left(\frac{v}{R}\right)^2 = \frac{1}{2}mv^2 + \frac{1}{4}mv^2 = \frac{3}{4}mv^2 \quad (8.9.4)$$

Thus, the speed of the rod as it leaves the rails is

$$v = \sqrt{\frac{4I\ell Ba}{3m}} \quad (8.9.5)$$

8.9.2 Suspended Conducting Rod

A conducting rod having a mass density λ kg/m is suspended by two flexible wires in a uniform magnetic field $\vec{\mathbf{B}}$ which points out of the page, as shown in Figure 8.9.2.

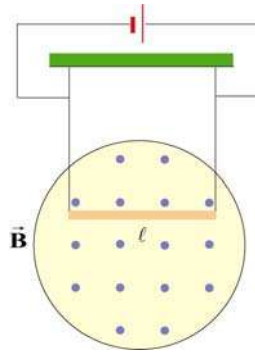
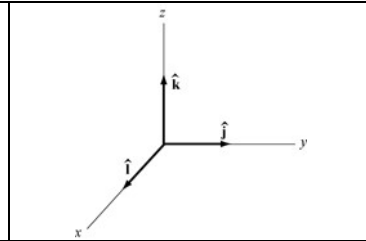

Figure 8.9.2 Suspended conducting rod in uniform magnetic field

If the tension on the wires is zero, what are the magnitude and the direction of the current in the rod?

Solution:

In order that the tension in the wires be zero, the magnetic force $\vec{\mathbf{F}}_B = I\vec{\ell} \times \vec{\mathbf{B}}$ acting on the conductor must exactly cancel the downward gravitational force $\vec{\mathbf{F}}_g = -mg\hat{\mathbf{k}}$.



For $\vec{\mathbf{F}}_B$ to point in the $+z$ -direction, we must have $\vec{\ell} = -\ell\hat{\mathbf{j}}$, i.e., the current flows to the left, so that

$$\vec{\mathbf{F}}_B = I\vec{\ell} \times \vec{\mathbf{B}} = I(-\ell\hat{\mathbf{j}}) \times (B\hat{\mathbf{i}}) = -I\ell B(\hat{\mathbf{j}} \times \hat{\mathbf{i}}) = +I\ell B\hat{\mathbf{k}} \quad (8.9.6)$$

The magnitude of the current can be obtain from

$$I\ell B = mg \quad (8.9.7)$$

or

$$I = \frac{mg}{B\ell} = \frac{\lambda g}{B} \quad (8.9.8)$$

8.9.3 Charged Particles in Magnetic Field

Particle A with charge q and mass m_A and particle B with charge $2q$ and mass m_B , are accelerated from rest by a potential difference ΔV , and subsequently deflected by a uniform magnetic field into semicircular paths. The radii of the trajectories by particle A and B are R and $2R$, respectively. The direction of the magnetic field is perpendicular to the velocity of the particle. What is their mass ratio?

Solution:

The kinetic energy gained by the charges is equal to

$$\frac{1}{2}mv^2 = q\Delta V \quad (8.9.9)$$

which yields

$$v = \sqrt{\frac{2q\Delta V}{m}} \quad (8.9.10)$$

The charges move in semicircles, since the magnetic force points radially inward and provides the source of the centripetal force:

$$\frac{mv^2}{r} = qvB \quad (8.9.11)$$

The radius of the circle can be readily obtained as:

$$r = \frac{mv}{qB} = \frac{m}{qB} \sqrt{\frac{2q\Delta V}{m}} = \frac{1}{B} \sqrt{\frac{2m\Delta V}{q}} \quad (8.9.12)$$

which shows that r is proportional to $(m/q)^{1/2}$. The mass ratio can then be obtained from

$$\frac{r_A}{r_B} = \frac{(m_A/q_A)^{1/2}}{(m_B/q_B)^{1/2}} \Rightarrow \frac{R}{2R} = \frac{(m_A/q)^{1/2}}{(m_B/2q)^{1/2}} \quad (8.9.13)$$

which gives

$$\frac{m_A}{m_B} = \frac{1}{8} \quad (8.9.14)$$

8.9.4 Bar Magnet in Non-Uniform Magnetic Field

A bar magnet with its north pole up is placed along the symmetric axis below a horizontal conducting ring carrying current I , as shown in the Figure 8.9.3. At the location of the ring, the magnetic field makes an angle θ with the vertical. What is the force on the ring?

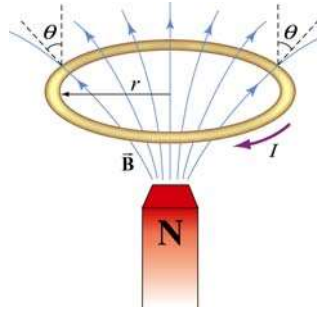

Figure 8.9.3 A bar magnet approaching a conducting ring

Solution:

The magnetic force acting on a small differential current-carrying element $I d\vec{s}$ on the ring is given by $d\vec{F}_B = I d\vec{s} \times \vec{B}$, where \vec{B} is the magnetic field due to the bar magnet. Using cylindrical coordinates $(\hat{r}, \hat{\phi}, \hat{z})$ as shown in Figure 8.9.4, we have

$$d\vec{F}_B = I(-ds \hat{\phi}) \times (B \sin \theta \hat{r} + B \cos \theta \hat{z}) = (IBds) \sin \theta \hat{z} - (IBds) \cos \theta \hat{r} \quad (8.9.15)$$

Due to the axial symmetry, the radial component of the force will exactly cancel, and we are left with the z -component.

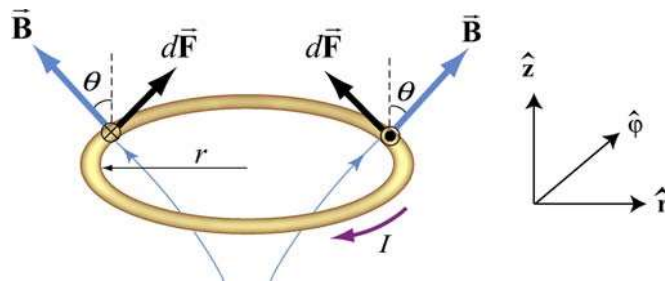

Figure 8.9.4 Magnetic force acting on the conducting ring

The total force acting on the ring then becomes

$$\vec{F}_B = (IB \sin \theta) \hat{z} \oint ds = (2\pi r IB \sin \theta) \hat{z} \quad (8.9.16)$$

The force points in the $+z$ direction and therefore is repulsive.

8.10 Conceptual Questions

1. Can a charged particle move through a uniform magnetic field without experiencing any force? Explain.
2. If no work can be done on a charged particle by the magnetic field, how can the motion of the particle be influenced by the presence of a field?
3. Suppose a charged particle is moving under the influence of both electric and magnetic fields. How can the effect of the two fields on the motion of the particle be distinguished?
4. What type of magnetic field can exert a force on a magnetic dipole? Is the force repulsive or attractive?
5. If a compass needle is placed in a uniform magnetic field, is there a net magnetic force acting on the needle? Is there a net torque?

8.11 Additional Problems

8.11.1 Force Exerted by a Magnetic Field

The electrons in the beam of television tube have an energy of 12 keV ($1 \text{ eV} = 1.6 \times 10^{-19} \text{ J}$). The tube is oriented so that the electrons move horizontally from south to north. At MIT, the Earth's magnetic field points roughly vertically down (i.e. neglect the component that is directed toward magnetic north) and has magnitude $B \sim 5 \times 10^{-5} \text{ T}$.

- (a) In what direction will the beam deflect?
- (b) What is the acceleration of a given electron associated with this deflection? [Ans. $\sim 10^{-15} \text{ m/s}^2$.]
- (c) How far will the beam deflect in moving 0.20 m through the television tube?

8.11.2 Magnetic Force on a Current Carrying Wire

A square loop of wire, of length $\ell = 0.1 \text{ m}$ on each side, has a mass of 50 g and pivots about an axis AA' that corresponds to a horizontal side of the square, as shown in Figure 8.11.1. A magnetic field of 500 G, directed vertically downward, uniformly fills the region in the vicinity of the loop. The loop carries a current I so that it is in equilibrium at $\theta = 20^\circ$.

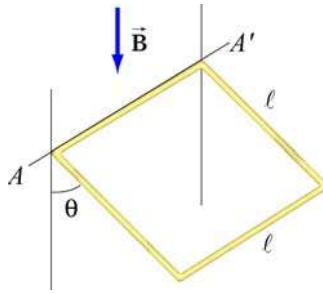

Figure 8.11.1 Magnetic force on a current-carrying square loop.

- Consider the force on each segment separately and find the direction of the current that flows in the loop to maintain the 20° angle.
- Calculate the torque about the axis due to these forces.
- Find the current in the loop by requiring the sum of all torques (about the axis) to be zero. (Hint: Consider the effect of gravity on each of the 4 segments of the wire separately.) [Ans. $I \sim 20$ A.]
- Determine the magnitude and direction of the force exerted on the axis by the pivots.
- Repeat part (b) by now using the definition of a magnetic dipole to calculate the torque exerted on such a loop due to the presence of a magnetic field.

8.11.3 Sliding Bar

A conducting bar of length l is placed on a frictionless inclined plane which is tilted at an angle θ from the horizontal, as shown in Figure 8.11.2.

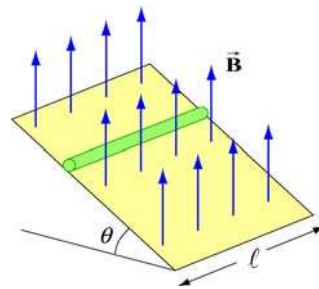

Figure 8.11.2 Magnetic force on a conducting bar

A uniform magnetic field is applied in the vertical direction. To prevent the bar from sliding down, a voltage source is connected to the ends of the bar with current flowing through. Determine the magnitude and the direction of the current such that the bar will remain stationary.

8.11.4 Particle Trajectory

A particle of charge $-q$ is moving with a velocity \vec{v} . It then enters midway between two plates where there exists a uniform magnetic field pointing into the page, as shown in Figure 8.11.3.

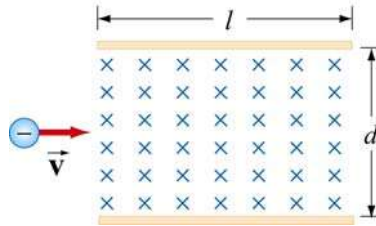

Figure 8.11.3 Charged particle moving under the influence of a magnetic field

- Is the trajectory of the particle deflected upward or downward?
- Compute the distance between the left end of the plate and where the particle strikes.

8.11.5 Particle Orbits in a Magnetic Field

Suppose the entire x - y plane to the right of the origin O is filled with a uniform magnetic field \vec{B} pointing out of the page, as shown in Figure 8.11.4.

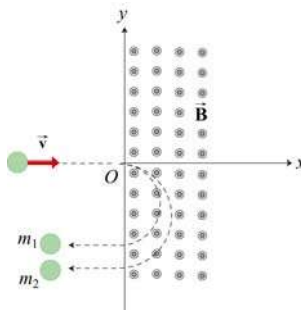

Figure 8.11.4

Two charged particles travel along the negative x axis in the positive x direction, each with speed v , and enter the magnetic field at the origin O . The two particles have the same charge q , but have different masses, m_1 and m_2 . When in the magnetic field, their trajectories both curve in the same direction, but describe semi-circles with different radii. The radius of the semi-circle traced out by particle 2 is exactly *twice* as big as the radius of the semi-circle traced out by particle 1.

- Is the charge q of these particles such that $q > 0$, or is $q < 0$?

(b) *Derive* (do not simply state) an expression for the radius R_1 of the semi-circle traced out by particle 1, in terms of q , v , B , and m_1 .

(c) What is the ratio m_2 / m_1 ?

(d) Is it possible to apply an electric field \vec{E} in the region $x > 0$ only which will cause both particles to continue to move in a straight line after they enter the region $x > 0$? If so, indicate the magnitude and direction of that electric field, in terms of the quantities given. If not, why not?

8.11.6 Force and Torque on a Current Loop

A current loop consists of a semicircle of radius R and two straight segments of length ℓ with an angle θ between them. The loop is then placed in a uniform magnetic field pointing to the right, as shown in Figure 8.11.5.

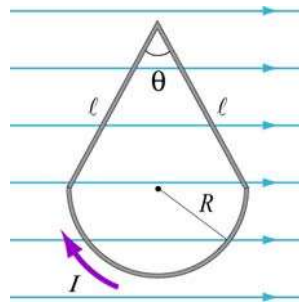

Figure 8.11.5 Current loop placed in a uniform magnetic field

(a) Find the net force on the current loop.

(b) Find the net torque on the current loop.

8.11.7 Force on a Wire

A straight wire of length 0.2 m carries a 7.0 A current. It is immersed in a uniform magnetic field of 0.1 T whose direction lies 20 degrees from the direction of the current.

(a) What is the direction of the force on the wire? Make a sketch to show your answer.

(b) What is the magnitude of the force? [Ans. ~ 0.05 N]

(c) How could you maximize the force without changing the field or current?

8.11.8 Levitating Wire

A copper wire of diameter d carries a current density \vec{J} at the Earth's equator where the Earth's magnetic field is horizontal, points north, and has magnitude $B = 0.5 \times 10^{-4} \text{ T}$. The wire lies in a plane that is parallel to the surface of the Earth and is oriented in the east-west direction. The density and resistivity of copper are $\rho_m = 8.9 \times 10^3 \text{ kg/m}^3$ and $\rho = 1.7 \times 10^{-8} \Omega \cdot \text{m}$, respectively.

(a) How large must \vec{J} be, and which direction must it flow in order to levitate the wire? Use $g = 9.8 \text{ m/s}^2$

(b) When the wire is floating how much power will be dissipated per cubic centimeter?

Chapter 9

Sources of Magnetic Fields

9.1 Biot-Savart Law	2
Interactive Simulation 9.1 : Magnetic Field of a Current Element.....	3
Example 9.1: Magnetic Field due to a Finite Straight Wire	3
Example 9.2: Magnetic Field due to a Circular Current Loop	6
9.1.1 Magnetic Field of a Moving Point Charge	9
Animation 9.1 : Magnetic Field of a Moving Charge	10
Animation 9.2 : Magnetic Field of Several Charges Moving in a Circle.....	11
Interactive Simulation 9.2 : Magnetic Field of a Ring of Moving Charges	11
9.2 Force Between Two Parallel Wires	12
Animation 9.3 : Forces Between Current-Carrying Parallel Wires.....	13
9.3 Ampere’s Law.....	13
Example 9.3: Field Inside and Outside a Current-Carrying Wire.....	16
Example 9.4: Magnetic Field Due to an Infinite Current Sheet	17
9.4 Solenoid	19
Example 9.5: Toroid.....	22
9.5 Magnetic Field of a Dipole	23
9.5.1 Earth’s Magnetic Field at MIT	24
Animation 9.4 : A Bar Magnet in the Earth’s Magnetic Field	26
9.6 Magnetic Materials	27
9.6.1 Magnetization	27
9.6.2 Paramagnetism.....	30
9.6.3 Diamagnetism	31
9.6.4 Ferromagnetism	31
9.7 Summary	32
9.8 Appendix 1: Magnetic Field off the Symmetry Axis of a Current Loop.....	34
9.9 Appendix 2: Helmholtz Coils	38
Animation 9.5 : Magnetic Field of the Helmholtz Coils	40
Animation 9.6 : Magnetic Field of Two Coils Carrying Opposite Currents	42
Animation 9.7 : Forces Between Coaxial Current-Carrying Wires.....	43

Animation 9.8: Magnet Oscillating Between Two Coils	43
Animation 9.9: Magnet Suspended Between Two Coils.....	44
9.10 Problem-Solving Strategies	45
9.10.1 Biot-Savart Law:.....	45
9.10.2 Ampere's law:.....	47
9.11 Solved Problems	48
9.11.1 Magnetic Field of a Straight Wire	48
9.11.2 Current-Carrying Arc.....	50
9.11.3 Rectangular Current Loop.....	51
9.11.4 Hairpin-Shaped Current-Carrying Wire.....	53
9.11.5 Two Infinitely Long Wires	54
9.11.6 Non-Uniform Current Density	56
9.11.7 Thin Strip of Metal.....	58
9.11.8 Two Semi-Infinite Wires	60
9.12 Conceptual Questions	61
9.13 Additional Problems	62
9.13.1 Application of Ampere's Law	62
9.13.2 Magnetic Field of a Current Distribution from Ampere's Law.....	62
9.13.3 Cylinder with a Hole.....	63
9.13.4 The Magnetic Field Through a Solenoid	64
9.13.5 Rotating Disk	64
9.13.6 Four Long Conducting Wires	64
9.13.7 Magnetic Force on a Current Loop.....	65
9.13.8 Magnetic Moment of an Orbital Electron.....	65
9.13.9 Ferromagnetism and Permanent Magnets.....	66
9.13.10 Charge in a Magnetic Field.....	67
9.13.11 Permanent Magnets.....	67
9.13.12 Magnetic Field of a Solenoid.....	67
9.13.13 Effect of Paramagnetism.....	68

Sources of Magnetic Fields

9.1 Biot-Savart Law

Currents which arise due to the motion of charges are the source of magnetic fields. When charges move in a conducting wire and produce a current I , the magnetic field at any point P due to the current can be calculated by adding up the magnetic field contributions, $d\vec{B}$, from small segments of the wire $d\vec{s}$, (Figure 9.1.1).

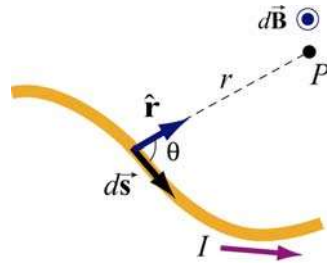

Figure 9.1.1 Magnetic field $d\vec{B}$ at point P due to a current-carrying element $I d\vec{s}$.

These segments can be thought of as a vector quantity having a magnitude of the length of the segment and pointing in the direction of the current flow. The infinitesimal current source can then be written as $I d\vec{s}$.

Let r denote as the distance from the current source to the field point P , and \hat{r} the corresponding unit vector. The Biot-Savart law gives an expression for the magnetic field contribution, $d\vec{B}$, from the current source, $I d\vec{s}$,

$$\boxed{d\vec{B} = \frac{\mu_0}{4\pi} \frac{I d\vec{s} \times \hat{r}}{r^2}} \quad (9.1.1)$$

where μ_0 is a constant called the *permeability of free space*:

$$\mu_0 = 4\pi \times 10^{-7} \text{ T} \cdot \text{m/A} \quad (9.1.2)$$

Notice that the expression is remarkably similar to the Coulomb's law for the electric field due to a charge element dq :

$$d\vec{E} = \frac{1}{4\pi\epsilon_0} \frac{dq}{r^2} \hat{r} \quad (9.1.3)$$

Adding up these contributions to find the magnetic field at the point P requires integrating over the current source,

$$\vec{\mathbf{B}} = \int_{\text{wire}} d\vec{\mathbf{B}} = \frac{\mu_0 I}{4\pi} \int_{\text{wire}} \frac{d\vec{\mathbf{s}} \times \hat{\mathbf{r}}}{r^2} \quad (9.1.4)$$

The integral is a vector integral, which means that the expression for $\vec{\mathbf{B}}$ is really three integrals, one for each component of $\vec{\mathbf{B}}$. The vector nature of this integral appears in the cross product $I d\vec{\mathbf{s}} \times \hat{\mathbf{r}}$. Understanding how to evaluate this cross product and then perform the integral will be the key to learning how to use the Biot-Savart law.

Interactive Simulation 9.1: Magnetic Field of a Current Element

Figure 9.1.2 is an interactive ShockWave display that shows the magnetic field of a current element from Eq. (9.1.1). This interactive display allows you to move the position of the observer about the source current element to see how moving that position changes the value of the magnetic field at the position of the observer.

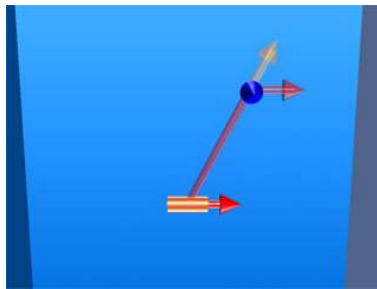

Figure 9.1.2 Magnetic field of a current element.

Example 9.1: Magnetic Field due to a Finite Straight Wire

A thin, straight wire carrying a current I is placed along the x -axis, as shown in Figure 9.1.3. Evaluate the magnetic field at point P . Note that we have assumed that the leads to the ends of the wire make canceling contributions to the net magnetic field at the point P .

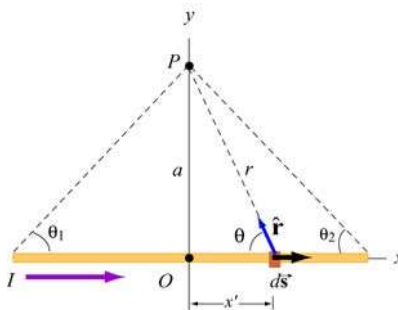

Figure 9.1.3 A thin straight wire carrying a current I .

Solution:

This is a typical example involving the use of the Biot-Savart law. We solve the problem using the methodology summarized in Section 9.10.

(1) Source point (coordinates denoted with a prime)

Consider a differential element $d\vec{s} = dx'\hat{\mathbf{i}}$ carrying current I in the x -direction. The location of this source is represented by $\vec{\mathbf{r}}' = x'\hat{\mathbf{i}}$.

(2) Field point (coordinates denoted with a subscript “ P ”)

Since the field point P is located at $(x, y) = (0, a)$, the position vector describing P is $\vec{\mathbf{r}}_P = a\hat{\mathbf{j}}$.

(3) Relative position vector

The vector $\vec{\mathbf{r}} = \vec{\mathbf{r}}_P - \vec{\mathbf{r}}'$ is a “relative” position vector which points from the source point to the field point. In this case, $\vec{\mathbf{r}} = a\hat{\mathbf{j}} - x'\hat{\mathbf{i}}$, and the magnitude $r = |\vec{\mathbf{r}}| = \sqrt{a^2 + x'^2}$ is the distance from between the source and P . The corresponding unit vector is given by

$$\hat{\mathbf{r}} = \frac{\vec{\mathbf{r}}}{r} = \frac{a\hat{\mathbf{j}} - x'\hat{\mathbf{i}}}{\sqrt{a^2 + x'^2}} = \sin\theta\hat{\mathbf{j}} - \cos\theta\hat{\mathbf{i}}$$

(4) The cross product $d\vec{\mathbf{s}} \times \hat{\mathbf{r}}$

The cross product is given by

$$d\vec{\mathbf{s}} \times \hat{\mathbf{r}} = (dx'\hat{\mathbf{i}}) \times (-\cos\theta\hat{\mathbf{i}} + \sin\theta\hat{\mathbf{j}}) = (dx'\sin\theta)\hat{\mathbf{k}}$$

(5) Write down the contribution to the magnetic field due to $I d\vec{\mathbf{s}}$

The expression is

$$d\vec{\mathbf{B}} = \frac{\mu_0 I}{4\pi} \frac{d\vec{\mathbf{s}} \times \hat{\mathbf{r}}}{r^2} = \frac{\mu_0 I}{4\pi} \frac{dx \sin\theta}{r^2} \hat{\mathbf{k}}$$

which shows that the magnetic field at P will point in the $+\hat{\mathbf{k}}$ direction, or out of the page.

(6) Simplify and carry out the integration

The variables θ , x and r are not independent of each other. In order to complete the integration, let us rewrite the variables x and r in terms of θ . From Figure 9.1.3, we have

$$\begin{cases} r = a / \sin \theta = a \csc \theta \\ x = a \cot \theta \Rightarrow dx = -a \csc^2 \theta d\theta \end{cases}$$

Upon substituting the above expressions, the differential contribution to the magnetic field is obtained as

$$dB = \frac{\mu_0 I (-a \csc^2 \theta d\theta) \sin \theta}{4\pi (a \csc \theta)^2} = -\frac{\mu_0 I}{4\pi a} \sin \theta d\theta$$

Integrating over all angles subtended from $-\theta_1$ to θ_2 (a negative sign is needed for θ_1 in order to take into consideration the portion of the length extended in the negative x axis from the origin), we obtain

$$\boxed{B = -\frac{\mu_0 I}{4\pi a} \int_{-\theta_1}^{\theta_2} \sin \theta d\theta = \frac{\mu_0 I}{4\pi a} (\cos \theta_2 + \cos \theta_1)} \quad (9.1.5)$$

The first term involving θ_2 accounts for the contribution from the portion along the $+x$ axis, while the second term involving θ_1 contains the contribution from the portion along the $-x$ axis. The two terms add!

Let's examine the following cases:

(i) In the symmetric case where $\theta_2 = -\theta_1$, the field point P is located along the perpendicular bisector. If the length of the rod is $2L$, then $\cos \theta_1 = L / \sqrt{L^2 + a^2}$ and the magnetic field is

$$B = \frac{\mu_0 I}{2\pi a} \cos \theta_1 = \frac{\mu_0 I}{2\pi a} \frac{L}{\sqrt{L^2 + a^2}} \quad (9.1.6)$$

(ii) The infinite length limit $L \rightarrow \infty$

This limit is obtained by choosing $(\theta_1, \theta_2) = (0, 0)$. The magnetic field at a distance a away becomes

$$\boxed{B = \frac{\mu_0 I}{2\pi a}} \quad (9.1.7)$$

Note that in this limit, the system possesses cylindrical symmetry, and the magnetic field lines are circular, as shown in Figure 9.1.4.

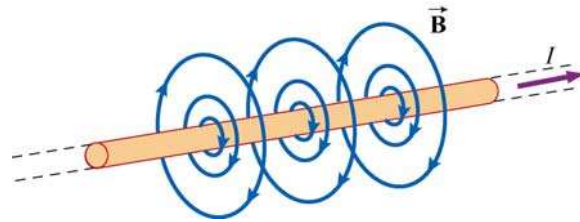

Figure 9.1.4 Magnetic field lines due to an infinite wire carrying current I .

In fact, the direction of the magnetic field due to a long straight wire can be determined by the right-hand rule (Figure 9.1.5).

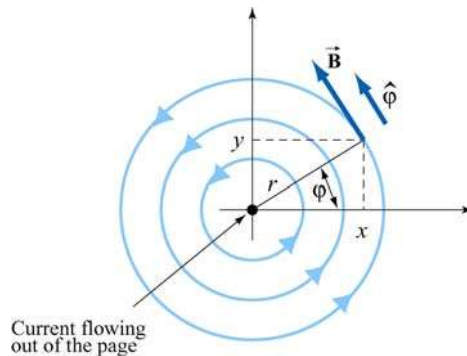

Figure 9.1.5 Direction of the magnetic field due to an infinite straight wire

If you direct your right thumb along the direction of the current in the wire, then the fingers of your right hand curl in the direction of the magnetic field. In cylindrical coordinates (r, φ, z) where the unit vectors are related by $\hat{\mathbf{r}} \times \hat{\boldsymbol{\varphi}} = \hat{\mathbf{z}}$, if the current flows in the $+z$ -direction, then, using the Biot-Savart law, the magnetic field must point in the φ -direction.

Example 9.2: Magnetic Field due to a Circular Current Loop

A circular loop of radius R in the xy plane carries a steady current I , as shown in Figure 9.1.6.

(a) What is the magnetic field at a point P on the axis of the loop, at a distance z from the center?

(b) If we place a magnetic dipole $\vec{\mu} = \mu_z \hat{\mathbf{k}}$ at P , find the magnetic force experienced by the dipole. Is the force attractive or repulsive? What happens if the direction of the dipole is reversed, i.e., $\vec{\mu} = -\mu_z \hat{\mathbf{k}}$

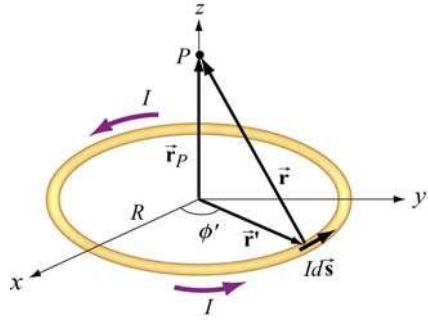

Figure 9.1.6 Magnetic field due to a circular loop carrying a steady current.

Solution:

(a) This is another example that involves the application of the Biot-Savart law. Again let's find the magnetic field by applying the same methodology used in Example 9.1.

(1) Source point

In Cartesian coordinates, the differential current element located at $\vec{r}' = R(\cos \phi' \hat{i} + \sin \phi' \hat{j})$ can be written as $Id\vec{s} = I(d\vec{r}'/d\phi')d\phi' = IRd\phi'(-\sin \phi' \hat{i} + \cos \phi' \hat{j})$.

(2) Field point

Since the field point P is on the axis of the loop at a distance z from the center, its position vector is given by $\vec{r}_p = z\hat{k}$.

(3) Relative position vector $\vec{r} = \vec{r}_p - \vec{r}'$

The relative position vector is given by

$$\vec{r} = \vec{r}_p - \vec{r}' = -R \cos \phi' \hat{i} - R \sin \phi' \hat{j} + z \hat{k} \quad (9.1.8)$$

and its magnitude

$$r = |\vec{r}| = \sqrt{(-R \cos \phi')^2 + (-R \sin \phi')^2 + z^2} = \sqrt{R^2 + z^2} \quad (9.1.9)$$

is the distance between the differential current element and P . Thus, the corresponding unit vector from $Id\vec{s}$ to P can be written as

$$\hat{r} = \frac{\vec{r}}{r} = \frac{\vec{r}_p - \vec{r}'}{|\vec{r}_p - \vec{r}'|}$$

(4) Simplifying the cross product

The cross product $d\vec{s} \times (\vec{r}_p - \vec{r}')$ can be simplified as

$$\begin{aligned} d\vec{s} \times (\vec{r}_p - \vec{r}') &= R d\phi' \left(-\sin \phi' \hat{i} + \cos \phi' \hat{j} \right) \times \left[-R \cos \phi' \hat{i} - R \sin \phi' \hat{j} + z \hat{k} \right] \\ &= R d\phi' \left[z \cos \phi' \hat{i} + z \sin \phi' \hat{j} + R \hat{k} \right] \end{aligned} \quad (9.1.10)$$

(5) Writing down $d\vec{B}$

Using the Biot-Savart law, the contribution of the current element to the magnetic field at P is

$$\begin{aligned} d\vec{B} &= \frac{\mu_0 I}{4\pi} \frac{d\vec{s} \times \hat{r}}{r^2} = \frac{\mu_0 I}{4\pi} \frac{d\vec{s} \times \vec{r}}{r^3} = \frac{\mu_0 I}{4\pi} \frac{d\vec{s} \times (\vec{r}_p - \vec{r}')}{|\vec{r}_p - \vec{r}'|^3} \\ &= \frac{\mu_0 IR}{4\pi} \frac{z \cos \phi' \hat{i} + z \sin \phi' \hat{j} + R \hat{k}}{(R^2 + z^2)^{3/2}} d\phi' \end{aligned} \quad (9.1.11)$$

(6) Carrying out the integration

Using the result obtained above, the magnetic field at P is

$$\vec{B} = \frac{\mu_0 IR}{4\pi} \int_0^{2\pi} \frac{z \cos \phi' \hat{i} + z \sin \phi' \hat{j} + R \hat{k}}{(R^2 + z^2)^{3/2}} d\phi' \quad (9.1.12)$$

The x and the y components of \vec{B} can be readily shown to be zero:

$$B_x = \frac{\mu_0 IRz}{4\pi(R^2 + z^2)^{3/2}} \int_0^{2\pi} \cos \phi' d\phi' = \frac{\mu_0 IRz}{4\pi(R^2 + z^2)^{3/2}} \sin \phi' \Big|_0^{2\pi} = 0 \quad (9.1.13)$$

$$B_y = \frac{\mu_0 IRz}{4\pi(R^2 + z^2)^{3/2}} \int_0^{2\pi} \sin \phi' d\phi' = -\frac{\mu_0 IRz}{4\pi(R^2 + z^2)^{3/2}} \cos \phi' \Big|_0^{2\pi} = 0 \quad (9.1.14)$$

On the other hand, the z component is

$$B_z = \frac{\mu_0}{4\pi} \frac{IR^2}{(R^2 + z^2)^{3/2}} \int_0^{2\pi} d\phi' = \frac{\mu_0}{4\pi} \frac{2\pi IR^2}{(R^2 + z^2)^{3/2}} = \frac{\mu_0 IR^2}{2(R^2 + z^2)^{3/2}} \quad (9.1.15)$$

Thus, we see that along the symmetric axis, B_z is the only non-vanishing component of the magnetic field. The conclusion can also be reached by using the symmetry arguments.

The behavior of B_z/B_0 where $B_0 = \mu_0 I / 2R$ is the magnetic field strength at $z = 0$, as a function of z/R is shown in Figure 9.1.7:

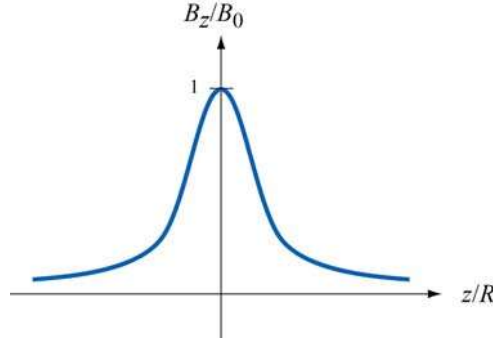

Figure 9.1.7 The ratio of the magnetic field, B_z / B_0 , as a function of z / R

(b) If we place a magnetic dipole $\vec{\mu} = \mu_z \hat{\mathbf{k}}$ at the point P , as discussed in Chapter 8, due to the non-uniformity of the magnetic field, the dipole will experience a force given by

$$\vec{\mathbf{F}}_B = \nabla(\vec{\mu} \cdot \vec{\mathbf{B}}) = \nabla(\mu_z B_z) = \mu_z \left(\frac{dB_z}{dz} \right) \hat{\mathbf{k}} \quad (9.1.16)$$

Upon differentiating Eq. (9.1.15) and substituting into Eq. (9.1.16), we obtain

$$\vec{\mathbf{F}}_B = -\frac{3\mu_z \mu_0 I R^2 z}{2(R^2 + z^2)^{5/2}} \hat{\mathbf{k}} \quad (9.1.17)$$

Thus, the dipole is attracted toward the current-carrying ring. On the other hand, if the direction of the dipole is reversed, $\vec{\mu} = -\mu_z \hat{\mathbf{k}}$, the resulting force will be repulsive.

9.1.1 Magnetic Field of a Moving Point Charge

Suppose we have an infinitesimal current element in the form of a cylinder of cross-sectional area A and length ds consisting of n charge carriers per unit volume, all moving at a common velocity $\vec{\mathbf{v}}$ along the axis of the cylinder. Let I be the current in the element, which we define as the amount of charge passing through any cross-section of the cylinder per unit time. From Chapter 6, we see that the current I can be written as

$$n A q |\vec{\mathbf{v}}| = I \quad (9.1.18)$$

The total number of charge carriers in the current element is simply $dN = n A ds$, so that using Eq. (9.1.1), the magnetic field $d\vec{\mathbf{B}}$ due to the dN charge carriers is given by

$$d\vec{\mathbf{B}} = \frac{\mu_0}{4\pi} \frac{(nAq|\vec{\mathbf{v}}|)d\vec{\mathbf{s}} \times \hat{\mathbf{r}}}{r^2} = \frac{\mu_0}{4\pi} \frac{(nA ds)q\vec{\mathbf{v}} \times \hat{\mathbf{r}}}{r^2} = \frac{\mu_0}{4\pi} \frac{(dN)q\vec{\mathbf{v}} \times \hat{\mathbf{r}}}{r^2} \quad (9.1.19)$$

where r is the distance between the charge and the field point P at which the field is being measured, the unit vector $\hat{\mathbf{r}} = \vec{\mathbf{r}}/r$ points *from* the source of the field (the charge) *to* P . The differential length vector $d\vec{\mathbf{s}}$ is defined to be parallel to $\vec{\mathbf{v}}$. In case of a single charge, $dN = 1$, the above equation becomes

$$\vec{\mathbf{B}} = \frac{\mu_0}{4\pi} \frac{q\vec{\mathbf{v}} \times \hat{\mathbf{r}}}{r^2} \quad (9.1.20)$$

Note, however, that since a point charge does not constitute a steady current, the above equation strictly speaking only holds in the non-relativistic limit where $v \ll c$, the speed of light, so that the effect of “retardation” can be ignored.

The result may be readily extended to a collection of N point charges, each moving with a different velocity. Let the i th charge q_i be located at (x_i, y_i, z_i) and moving with velocity $\vec{\mathbf{v}}_i$. Using the superposition principle, the magnetic field at P can be obtained as:

$$\vec{\mathbf{B}} = \sum_{i=1}^N \frac{\mu_0}{4\pi} q_i \vec{\mathbf{v}}_i \times \left[\frac{(x-x_i)\hat{\mathbf{i}} + (y-y_i)\hat{\mathbf{j}} + (z-z_i)\hat{\mathbf{k}}}{[(x-x_i)^2 + (y-y_i)^2 + (z-z_i)^2]^{3/2}} \right] \quad (9.1.21)$$

Animation 9.1: Magnetic Field of a Moving Charge

Figure 9.1.8 shows one frame of the animations of the magnetic field of a moving positive and negative point charge, assuming the speed of the charge is small compared to the speed of light.

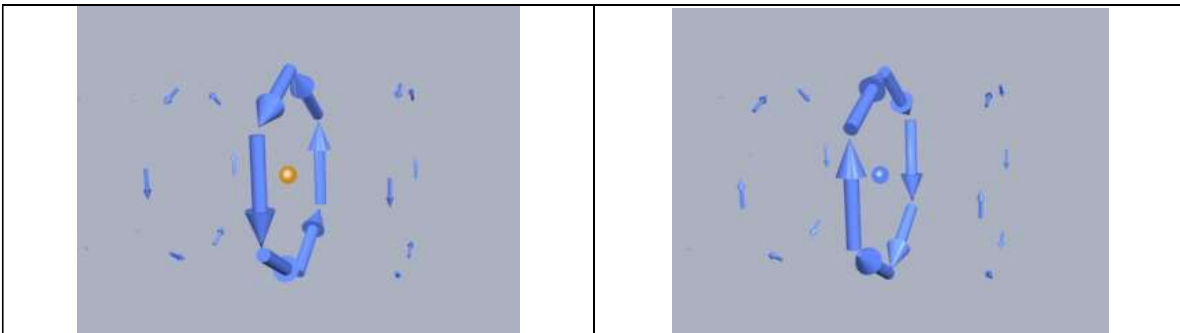

Figure 9.1.8 The magnetic field of (a) a moving positive charge, and (b) a moving negative charge, when the speed of the charge is small compared to the speed of light.

Animation 9.2: Magnetic Field of Several Charges Moving in a Circle

Suppose we want to calculate the magnetic fields of a number of charges moving on the circumference of a circle with equal spacing between the charges. To calculate this field we have to add up vectorially the magnetic fields of each of charges using Eq. (9.1.19).

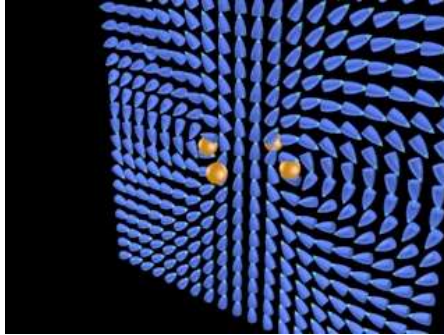

Figure 9.1.9 The magnetic field of four charges moving in a circle. We show the magnetic field vector directions in only one plane. The bullet-like icons indicate the direction of the magnetic field at that point in the array spanning the plane.

Figure 9.1.9 shows one frame of the animation when the number of moving charges is four. Other animations show the same situation for $N=1, 2,$ and 8 . When we get to eight charges, a characteristic pattern emerges--the magnetic dipole pattern. Far from the ring, the shape of the field lines is the same as the shape of the field lines for an electric dipole.

Interactive Simulation 9.2: Magnetic Field of a Ring of Moving Charges

Figure 9.1.10 shows a ShockWave display of the vectorial addition process for the case where we have 30 charges moving on a circle. The display in Figure 9.1.10 shows an observation point fixed on the axis of the ring. As the addition proceeds, we also show the resultant up to that point (large arrow in the display).

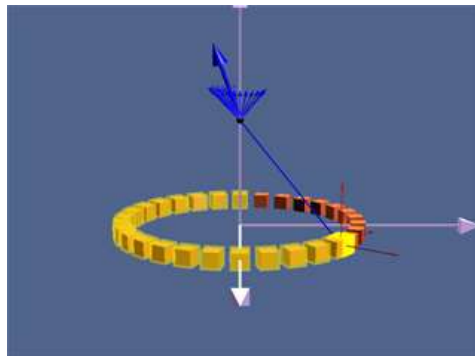

Figure 9.1.10 A ShockWave simulation of the use of the principle of superposition to find the magnetic field due to 30 moving charges moving in a circle at an observation point on the axis of the circle.

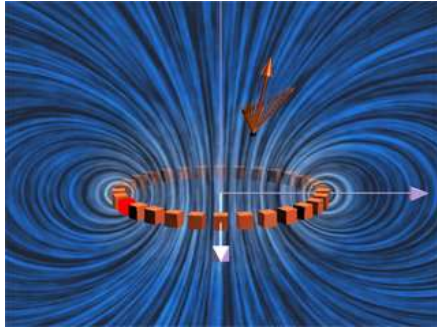

Figure 9.1.11 The magnetic field due to 30 charges moving in a circle at a given observation point. The position of the observation point can be varied to see how the magnetic field of the individual charges adds up to give the total field.

In Figure 9.1.11, we show an interactive ShockWave display that is similar to that in Figure 9.1.10, but now we can interact with the display to move the position of the observer about in space. To get a feel for the total magnetic field, we also show a “iron filings” representation of the magnetic field due to these charges. We can move the observation point about in space to see how the total field at various points arises from the individual contributions of the magnetic field of to each moving charge.

9.2 Force Between Two Parallel Wires

We have already seen that a current-carrying wire produces a magnetic field. In addition, when placed in a magnetic field, a wire carrying a current will experience a net force. Thus, we expect two current-carrying wires to exert force on each other.

Consider two parallel wires separated by a distance a and carrying currents I_1 and I_2 in the $+x$ -direction, as shown in Figure 9.2.1.

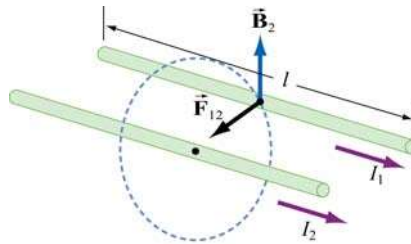

Figure 9.2.1 Force between two parallel wires

The magnetic force, \vec{F}_{12} , exerted on wire 1 by wire 2 may be computed as follows: Using the result from the previous example, the magnetic field lines due to I_2 going in the $+x$ -direction are circles concentric with wire 2, with the field \vec{B}_2 pointing in the tangential

direction. Thus, at an arbitrary point P on wire 1, we have $\vec{\mathbf{B}}_2 = -(\mu_0 I_2 / 2\pi a)\hat{\mathbf{j}}$, which points in the direction perpendicular to wire 1, as depicted in Figure 9.2.1. Therefore,

$$\vec{\mathbf{F}}_{12} = I_1 \vec{\mathbf{l}} \times \vec{\mathbf{B}}_2 = I_1 (l\hat{\mathbf{i}}) \times \left(-\frac{\mu_0 I_2}{2\pi a} \hat{\mathbf{j}} \right) = -\frac{\mu_0 I_1 I_2 l}{2\pi a} \hat{\mathbf{k}} \quad (9.2.1)$$

Clearly $\vec{\mathbf{F}}_{12}$ points toward wire 2. The conclusion we can draw from this simple calculation is that two parallel wires carrying currents in the same direction will attract each other. On the other hand, if the currents flow in opposite directions, the resultant force will be repulsive.

Animation 9.3: Forces Between Current-Carrying Parallel Wires

Figures 9.2.2 shows parallel wires carrying current in the same and in opposite directions. In the first case, the magnetic field configuration is such as to produce an attraction between the wires. In the second case the magnetic field configuration is such as to produce a repulsion between the wires.

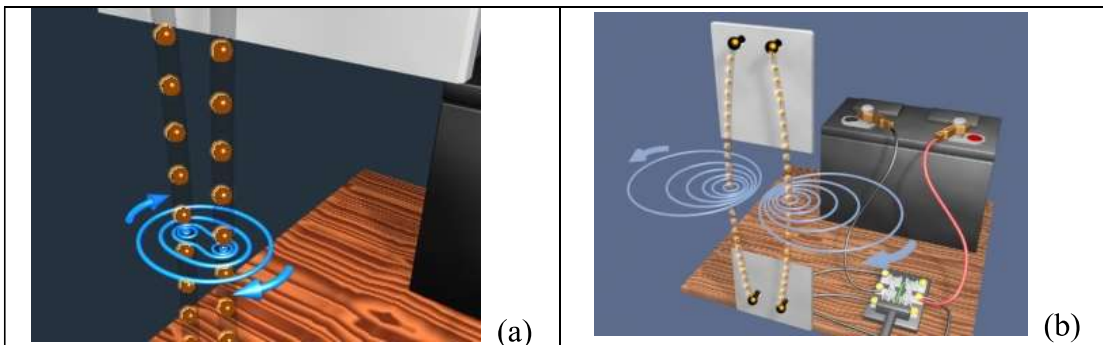

Figure 9.2.2 (a) The attraction between two wires carrying current in the same direction. The direction of current flow is represented by the motion of the orange spheres in the visualization. (b) The repulsion of two wires carrying current in opposite directions.

9.3 Ampere's Law

We have seen that moving charges or currents are the source of magnetism. This can be readily demonstrated by placing compass needles near a wire. As shown in Figure 9.3.1a, all compass needles point in the same direction in the absence of current. However, when $I \neq 0$, the needles will be deflected along the tangential direction of the circular path (Figure 9.3.1b).

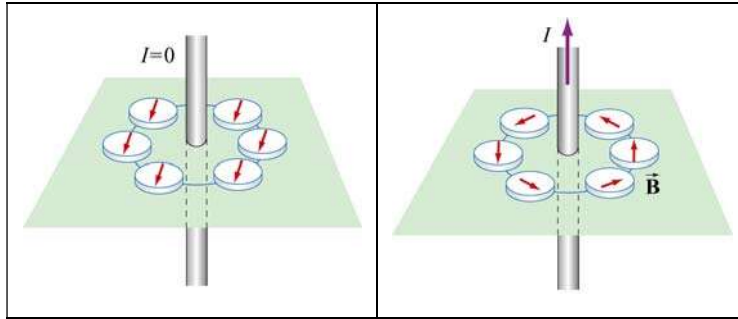

Figure 9.3.1 Deflection of compass needles near a current-carrying wire

Let us now divide a circular path of radius r into a large number of small length vectors $\Delta \vec{s} = \Delta s \hat{\phi}$, that point along the tangential direction with magnitude Δs (Figure 9.3.2).

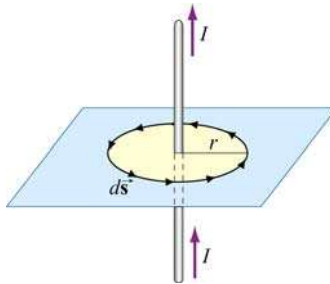

Figure 9.3.2 Amperian loop

In the limit $\Delta \vec{s} \rightarrow \vec{0}$, we obtain

$$\oint \vec{B} \cdot d\vec{s} = B \oint ds = \left(\frac{\mu_0 I}{2\pi r} \right) (2\pi r) = \mu_0 I \quad (9.3.1)$$

The result above is obtained by choosing a closed path, or an “Amperian loop” that follows one particular magnetic field line. Let’s consider a slightly more complicated Amperian loop, as that shown in Figure 9.3.3

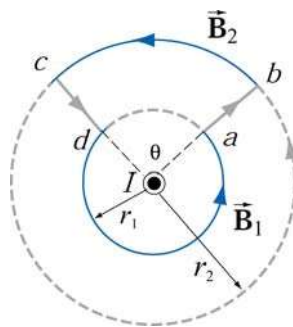

Figure 9.3.3 An Amperian loop involving two field lines

The line integral of the magnetic field around the contour $abcd$ is

$$\begin{aligned} \oint_{abcd} \vec{\mathbf{B}} \cdot d\vec{\mathbf{s}} &= \int_{ab} \vec{\mathbf{B}} \cdot d\vec{\mathbf{s}} + \int_{bc} \vec{\mathbf{B}} \cdot d\vec{\mathbf{s}} + \int_{cd} \vec{\mathbf{B}} \cdot d\vec{\mathbf{s}} + \int_{cd} \vec{\mathbf{B}} \cdot d\vec{\mathbf{s}} \\ &= 0 + B_2(r_2\theta) + 0 + B_1[r_1(2\pi - \theta)] \end{aligned} \quad (9.3.2)$$

where the length of arc bc is $r_2\theta$, and $r_1(2\pi - \theta)$ for arc da . The first and the third integrals vanish since the magnetic field is perpendicular to the paths of integration. With $B_1 = \mu_0 I / 2\pi r_1$ and $B_2 = \mu_0 I / 2\pi r_2$, the above expression becomes

$$\oint_{abcd} \vec{\mathbf{B}} \cdot d\vec{\mathbf{s}} = \frac{\mu_0 I}{2\pi r_2} (r_2\theta) + \frac{\mu_0 I}{2\pi r_1} [r_1(2\pi - \theta)] = \frac{\mu_0 I}{2\pi} \theta + \frac{\mu_0 I}{2\pi} (2\pi - \theta) = \mu_0 I \quad (9.3.3)$$

We see that the same result is obtained whether the closed path involves one or two magnetic field lines.

As shown in Example 9.1, in cylindrical coordinates (r, φ, z) with current flowing in the $+z$ -axis, the magnetic field is given by $\vec{\mathbf{B}} = (\mu_0 I / 2\pi r) \hat{\boldsymbol{\phi}}$. An arbitrary length element in the cylindrical coordinates can be written as

$$d\vec{\mathbf{s}} = dr \hat{\mathbf{r}} + r d\varphi \hat{\boldsymbol{\phi}} + dz \hat{\mathbf{z}} \quad (9.3.4)$$

which implies

$$\oint_{\text{closed path}} \vec{\mathbf{B}} \cdot d\vec{\mathbf{s}} = \oint_{\text{closed path}} \left(\frac{\mu_0 I}{2\pi r} \right) r d\varphi = \frac{\mu_0 I}{2\pi} \oint_{\text{closed path}} d\varphi = \frac{\mu_0 I}{2\pi} (2\pi) = \mu_0 I \quad (9.3.5)$$

In other words, the line integral of $\oint \vec{\mathbf{B}} \cdot d\vec{\mathbf{s}}$ around any closed Amperian loop is proportional to I_{enc} , the current encircled by the loop.

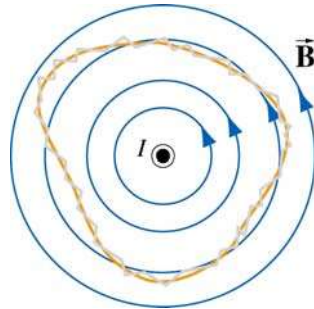

Figure 9.3.4 An Amperian loop of arbitrary shape.

The generalization to any closed loop of arbitrary shape (see for example, Figure 9.3.4) that involves many magnetic field lines is known as Ampere's law:

$$\oint \vec{\mathbf{B}} \cdot d\vec{\mathbf{s}} = \mu_0 I_{\text{enc}} \quad (9.3.6)$$

Ampere's law in magnetism is analogous to Gauss's law in electrostatics. In order to apply them, the system must possess certain symmetry. In the case of an infinite wire, the system possesses cylindrical symmetry and Ampere's law can be readily applied. However, when the length of the wire is finite, Biot-Savart law must be used instead.

Biot-Savart Law	$\vec{\mathbf{B}} = \frac{\mu_0 I}{4\pi} \int \frac{d\vec{\mathbf{s}} \times \hat{\mathbf{r}}}{r^2}$	general current source ex: finite wire
Ampere's law	$\oint \vec{\mathbf{B}} \cdot d\vec{\mathbf{s}} = \mu_0 I_{\text{enc}}$	current source has certain symmetry ex: infinite wire (cylindrical)

Ampere's law is applicable to the following current configurations:

1. Infinitely long straight wires carrying a steady current I (Example 9.3)
2. Infinitely large sheet of thickness b with a current density J (Example 9.4).
3. Infinite solenoid (Section 9.4).
4. Toroid (Example 9.5).

We shall examine all four configurations in detail.

Example 9.3: Field Inside and Outside a Current-Carrying Wire

Consider a long straight wire of radius R carrying a current I of uniform current density, as shown in Figure 9.3.5. Find the magnetic field everywhere.

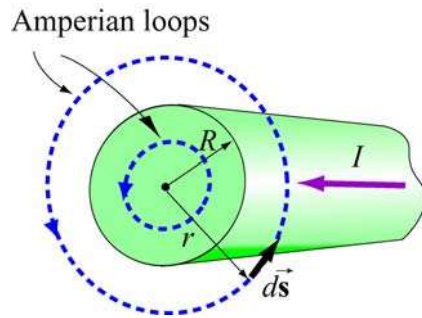

Figure 9.3.5 Amperian loops for calculating the $\vec{\mathbf{B}}$ field of a conducting wire of radius R .

Solution:

(i) Outside the wire where $r \geq R$, the Amperian loop (circle 1) completely encircles the current, i.e., $I_{\text{enc}} = I$. Applying Ampere's law yields

$$\oint \vec{\mathbf{B}} \cdot d\vec{\mathbf{s}} = B \oint ds = B(2\pi r) = \mu_0 I$$

which implies

$$B = \frac{\mu_0 I}{2\pi r}$$

(ii) Inside the wire where $r < R$, the amount of current encircled by the Amperian loop (circle 2) is proportional to the area enclosed, i.e.,

$$I_{\text{enc}} = \left(\frac{\pi r^2}{\pi R^2} \right) I$$

Thus, we have

$$\oint \vec{\mathbf{B}} \cdot d\vec{\mathbf{s}} = B(2\pi r) = \mu_0 I \left(\frac{\pi r^2}{\pi R^2} \right) \Rightarrow \boxed{B = \frac{\mu_0 I r}{2\pi R^2}}$$

We see that the magnetic field is zero at the center of the wire and increases linearly with r until $r=R$. Outside the wire, the field falls off as $1/r$. The qualitative behavior of the field is depicted in Figure 9.3.6 below:

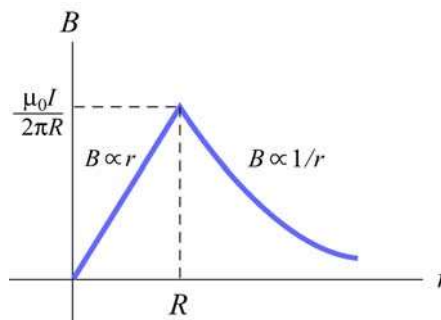

Figure 9.3.6 Magnetic field of a conducting wire of radius R carrying a steady current I .

Example 9.4: Magnetic Field Due to an Infinite Current Sheet

Consider an infinitely large sheet of thickness b lying in the xy plane with a uniform current density $\vec{\mathbf{J}} = J_0 \hat{\mathbf{i}}$. Find the magnetic field everywhere.

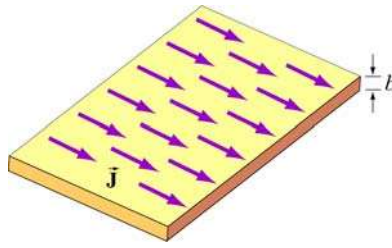

Figure 9.3.7 An infinite sheet with current density $\vec{J} = J_0 \hat{i}$.

Solution:

We may think of the current sheet as a set of parallel wires carrying currents in the $+x$ -direction. From Figure 9.3.8, we see that magnetic field at a point P above the plane points in the $-y$ -direction. The z -component vanishes after adding up the contributions from all wires. Similarly, we may show that the magnetic field at a point below the plane points in the $+y$ -direction.

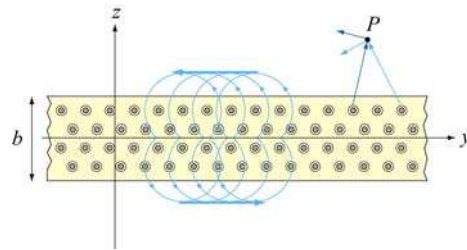

Figure 9.3.8 Magnetic field of a current sheet

We may now apply Ampere's law to find the magnetic field due to the current sheet. The Amperian loops are shown in Figure 9.3.9.

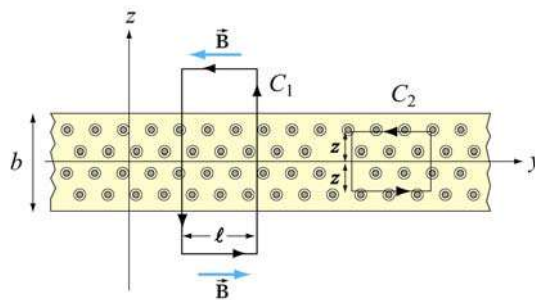

Figure 9.3.9 Amperian loops for the current sheets

For the field outside, we integrate along path C_1 . The amount of current enclosed by C_1 is

$$I_{\text{enc}} = \iint \vec{\mathbf{J}} \cdot d\vec{\mathbf{A}} = J_0(b\ell) \quad (9.3.7)$$

Applying Ampere's law leads to

$$\oint \vec{\mathbf{B}} \cdot d\vec{\mathbf{s}} = B(2\ell) = \mu_0 I_{\text{enc}} = \mu_0(J_0 b\ell) \quad (9.3.8)$$

or $B = \mu_0 J_0 b / 2$. Note that the magnetic field outside the sheet is constant, independent of the distance from the sheet. Next we find the magnetic field inside the sheet. The amount of current enclosed by path C_2 is

$$I_{\text{enc}} = \iint \vec{\mathbf{J}} \cdot d\vec{\mathbf{A}} = J_0(2|z|\ell) \quad (9.3.9)$$

Applying Ampere's law, we obtain

$$\oint \vec{\mathbf{B}} \cdot d\vec{\mathbf{s}} = B(2\ell) = \mu_0 I_{\text{enc}} = \mu_0 J_0(2|z|\ell) \quad (9.3.10)$$

or $B = \mu_0 J_0 |z|$. At $z = 0$, the magnetic field vanishes, as required by symmetry. The results can be summarized using the unit-vector notation as

$$\vec{\mathbf{B}} = \begin{cases} -\frac{\mu_0 J_0 b}{2} \hat{\mathbf{j}}, & z > b/2 \\ -\mu_0 J_0 z \hat{\mathbf{j}}, & -b/2 < z < b/2 \\ \frac{\mu_0 J_0 b}{2} \hat{\mathbf{j}}, & z < -b/2 \end{cases} \quad (9.3.11)$$

Let's now consider the limit where the sheet is infinitesimally thin, with $b \rightarrow 0$. In this case, instead of current density $\vec{\mathbf{J}} = J_0 \hat{\mathbf{i}}$, we have surface current $\vec{\mathbf{K}} = K \hat{\mathbf{i}}$, where $K = J_0 b$. Note that the dimension of K is current/length. In this limit, the magnetic field becomes

$$\vec{\mathbf{B}} = \begin{cases} -\frac{\mu_0 K}{2} \hat{\mathbf{j}}, & z > 0 \\ \frac{\mu_0 K}{2} \hat{\mathbf{j}}, & z < 0 \end{cases} \quad (9.3.12)$$

9.4 Solenoid

A solenoid is a long coil of wire tightly wound in the helical form. Figure 9.4.1 shows the magnetic field lines of a solenoid carrying a steady current I . We see that if the turns are closely spaced, the resulting magnetic field inside the solenoid becomes fairly uniform,

provided that the length of the solenoid is much greater than its diameter. For an “ideal” solenoid, which is infinitely long with turns tightly packed, the magnetic field inside the solenoid is uniform and parallel to the axis, and vanishes outside the solenoid.

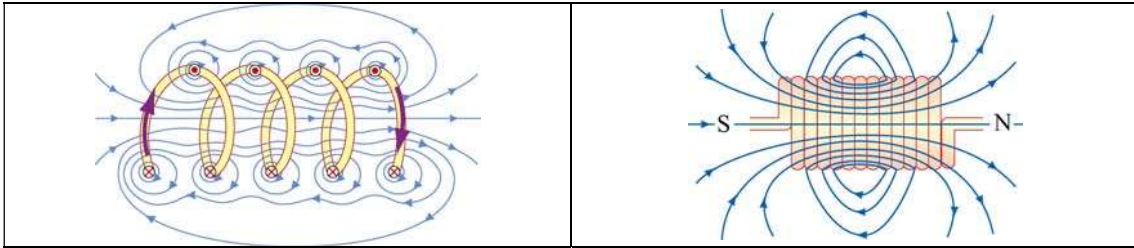

Figure 9.4.1 Magnetic field lines of a solenoid

We can use Ampere’s law to calculate the magnetic field strength inside an ideal solenoid. The cross-sectional view of an ideal solenoid is shown in Figure 9.4.2. To compute $\vec{\mathbf{B}}$, we consider a rectangular path of length l and width w and traverse the path in a counterclockwise manner. The line integral of $\vec{\mathbf{B}}$ along this loop is

$$\begin{aligned} \oint \vec{\mathbf{B}} \cdot d\vec{\mathbf{s}} &= \int_1 \vec{\mathbf{B}} \cdot d\vec{\mathbf{s}} + \int_2 \vec{\mathbf{B}} \cdot d\vec{\mathbf{s}} + \int_3 \vec{\mathbf{B}} \cdot d\vec{\mathbf{s}} + \int_4 \vec{\mathbf{B}} \cdot d\vec{\mathbf{s}} \\ &= 0 + 0 + Bl + 0 \end{aligned} \tag{9.4.1}$$

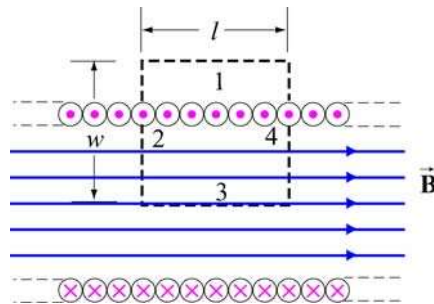

Figure 9.4.2 Amperian loop for calculating the magnetic field of an ideal solenoid.

In the above, the contributions along sides 2 and 4 are zero because $\vec{\mathbf{B}}$ is perpendicular to $d\vec{\mathbf{s}}$. In addition, $\vec{\mathbf{B}} = \vec{\mathbf{0}}$ along side 1 because the magnetic field is non-zero only inside the solenoid. On the other hand, the total current enclosed by the Amperian loop is $I_{\text{enc}} = NI$, where N is the total number of turns. Applying Ampere’s law yields

$$\oint \vec{\mathbf{B}} \cdot d\vec{\mathbf{s}} = Bl = \mu_0 NI \tag{9.4.2}$$

or

$$B = \frac{\mu_0 NI}{l} = \mu_0 nI \quad (9.4.3)$$

where $n = N/l$ represents the number of turns per unit length., In terms of the surface current, or current per unit length $K = nI$, the magnetic field can also be written as,

$$B = \mu_0 K \quad (9.4.4)$$

What happens if the length of the solenoid is finite? To find the magnetic field due to a finite solenoid, we shall approximate the solenoid as consisting of a large number of circular loops stacking together. Using the result obtained in Example 9.2, the magnetic field at a point P on the z axis may be calculated as follows: Take a cross section of tightly packed loops located at z' with a thickness dz' , as shown in Figure 9.4.3

The amount of current flowing through is proportional to the thickness of the cross section and is given by $dI = I(ndz') = I(N/l)dz'$, where $n = N/l$ is the number of turns per unit length.

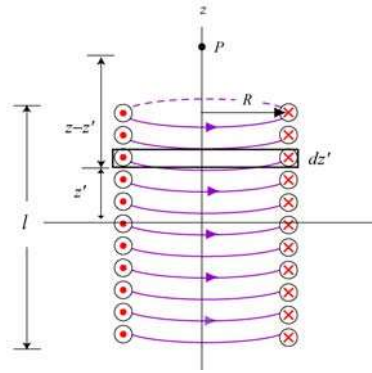

Figure 9.4.3 Finite Solenoid

The contribution to the magnetic field at P due to this subset of loops is

$$dB_z = \frac{\mu_0 R^2}{2[(z-z')^2 + R^2]^{3/2}} dI = \frac{\mu_0 R^2}{2[(z-z')^2 + R^2]^{3/2}} (nI dz') \quad (9.4.5)$$

Integrating over the entire length of the solenoid, we obtain

$$B_z = \frac{\mu_0 nIR^2}{2} \int_{-l/2}^{l/2} \frac{dz'}{[(z-z')^2 + R^2]^{3/2}} = \frac{\mu_0 nIR^2}{2} \left. \frac{z'-z}{R^2 \sqrt{(z-z')^2 + R^2}} \right|_{-l/2}^{l/2} \quad (9.4.6)$$

$$= \frac{\mu_0 nI}{2} \left[\frac{(l/2)-z}{\sqrt{(z-l/2)^2 + R^2}} + \frac{(l/2)+z}{\sqrt{(z+l/2)^2 + R^2}} \right]$$

A plot of B_z/B_0 , where $B_0 = \mu_0 nI$ is the magnetic field of an infinite solenoid, as a function of z/R is shown in Figure 9.4.4 for $l = 10R$ and $l = 20R$.

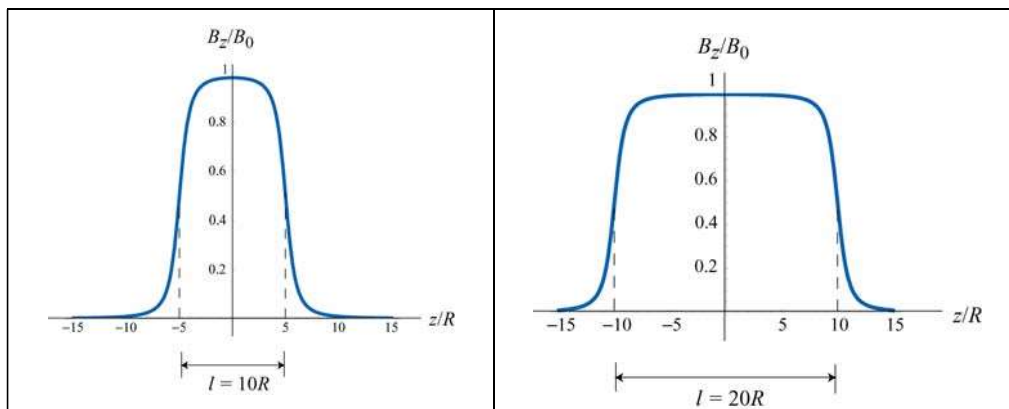

Figure 9.4.4 Magnetic field of a finite solenoid for (a) $l = 10R$, and (b) $l = 20R$.

Notice that the value of the magnetic field in the region $|z| < l/2$ is nearly uniform and approximately equal to B_0 .

Example 9.5: Toroid

Consider a toroid which consists of N turns, as shown in Figure 9.4.5. Find the magnetic field everywhere.

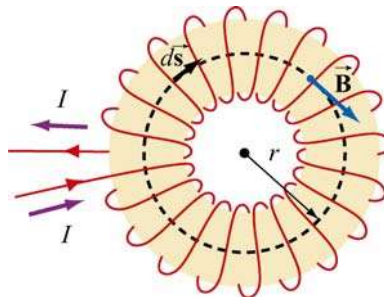

Figure 9.4.5 A toroid with N turns

Solutions:

One can think of a toroid as a solenoid wrapped around with its ends connected. Thus, the magnetic field is completely confined inside the toroid and the field points in the azimuthal direction (clockwise due to the way the current flows, as shown in Figure 9.4.5.)

Applying Ampere's law, we obtain

$$\oint \vec{\mathbf{B}} \cdot d\vec{\mathbf{s}} = \oint B ds = B \oint ds = B(2\pi r) = \mu_0 NI \quad (9.4.7)$$

or

$$B = \frac{\mu_0 NI}{2\pi r} \quad (9.4.8)$$

where r is the distance measured from the center of the toroid.. Unlike the magnetic field of a solenoid, the magnetic field inside the toroid is non-uniform and decreases as $1/r$.

9.5 Magnetic Field of a Dipole

Let a magnetic dipole moment vector $\vec{\mu} = -\mu\hat{\mathbf{k}}$ be placed at the origin (e.g., center of the Earth) in the yz plane. What is the magnetic field at a point (e.g., MIT) a distance r away from the origin?

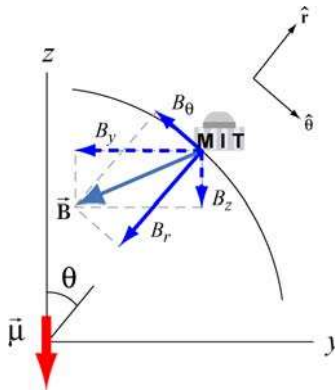

Figure 9.5.1 Earth's magnetic field components

In Figure 9.5.1 we show the magnetic field at MIT due to the dipole. The y - and z -components of the magnetic field are given by

$$B_y = -\frac{\mu_0}{4\pi} \frac{3\mu}{r^3} \sin\theta \cos\theta, \quad B_z = -\frac{\mu_0}{4\pi} \frac{\mu}{r^3} (3\cos^2\theta - 1) \quad (9.5.1)$$

Readers are referred to Section 9.8 for the detail of the derivation.

In spherical coordinates (r, θ, ϕ) , the radial and the polar components of the magnetic field can be written as

$$B_r = B_y \sin\theta + B_z \cos\theta = -\frac{\mu_0}{4\pi} \frac{2\mu}{r^3} \cos\theta \quad (9.5.2)$$

and

$$B_\theta = B_y \cos \theta - B_z \sin \theta = -\frac{\mu_0 \mu}{4\pi r^3} \sin \theta \quad (9.5.3)$$

respectively. Thus, the magnetic field at MIT due to the dipole becomes

$$\vec{\mathbf{B}} = B_\theta \hat{\boldsymbol{\theta}} + B_r \hat{\mathbf{r}} = -\frac{\mu_0 \mu}{4\pi r^3} (\sin \theta \hat{\boldsymbol{\theta}} + 2 \cos \theta \hat{\mathbf{r}}) \quad (9.5.4)$$

Notice the similarity between the above expression and the electric field due to an electric dipole $\vec{\mathbf{p}}$ (see Solved Problem 2.13.6):

$$\vec{\mathbf{E}} = \frac{1}{4\pi\epsilon_0} \frac{p}{r^3} (\sin \theta \hat{\boldsymbol{\theta}} + 2 \cos \theta \hat{\mathbf{r}})$$

The negative sign in Eq. (9.5.4) is due to the fact that the magnetic dipole points in the $-z$ -direction. In general, the magnetic field due to a dipole moment $\vec{\boldsymbol{\mu}}$ can be written as

$$\vec{\mathbf{B}} = \frac{\mu_0}{4\pi} \frac{3(\vec{\boldsymbol{\mu}} \cdot \hat{\mathbf{r}})\hat{\mathbf{r}} - \vec{\boldsymbol{\mu}}}{r^3} \quad (9.5.5)$$

The ratio of the radial and the polar components is given by

$$\frac{B_r}{B_\theta} = \frac{-\frac{\mu_0}{4\pi} \frac{2\mu}{r^3} \cos \theta}{-\frac{\mu_0}{4\pi} \frac{\mu}{r^3} \sin \theta} = 2 \cot \theta \quad (9.5.6)$$

9.5.1 Earth's Magnetic Field at MIT

The Earth's field behaves as if there were a bar magnet in it. In Figure 9.5.2 an imaginary magnet is drawn inside the Earth oriented to produce a magnetic field like that of the Earth's magnetic field. Note the South pole of such a magnet in the northern hemisphere in order to attract the North pole of a compass.

It is most natural to represent the location of a point P on the surface of the Earth using the spherical coordinates (r, θ, ϕ) , where r is the distance from the center of the Earth, θ is the polar angle from the z -axis, with $0 \leq \theta \leq \pi$, and ϕ is the azimuthal angle in the xy plane, measured from the x -axis, with $0 \leq \phi \leq 2\pi$ (See Figure 9.5.3.) With the distance fixed at $r = r_E$, the radius of the Earth, the point P is parameterized by the two angles θ and ϕ .

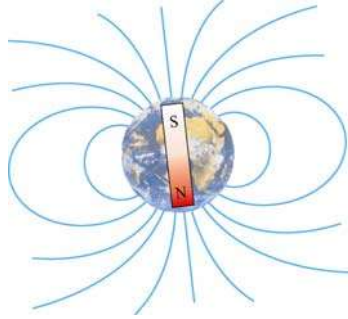

Figure 9.5.2 Magnetic field of the Earth

In practice, a location on Earth is described by two numbers – latitude and longitude. How are they related to θ and ϕ ? The latitude of a point, denoted as δ , is a measure of the elevation from the plane of the equator. Thus, it is related to θ (commonly referred to as the colatitude) by $\delta = 90^\circ - \theta$. Using this definition, the equator has latitude 0° , and the north and the south poles have latitude $\pm 90^\circ$, respectively.

The longitude of a location is simply represented by the azimuthal angle ϕ in the spherical coordinates. Lines of constant longitude are generally referred to as *meridians*. The value of longitude depends on where the counting begins. For historical reasons, the meridian passing through the Royal Astronomical Observatory in Greenwich, UK, is chosen as the “prime meridian” with zero longitude.

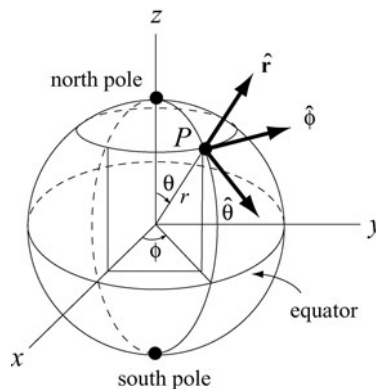

Figure 9.5.3 Locating a point P on the surface of the Earth using spherical coordinates.

Let the z -axis be the Earth’s rotation axis, and the x -axis passes through the prime meridian. The corresponding magnetic dipole moment of the Earth can be written as

$$\begin{aligned} \vec{\mu}_E &= \mu_E (\sin \theta_0 \cos \phi_0 \hat{\mathbf{i}} + \sin \theta_0 \sin \phi_0 \hat{\mathbf{j}} + \cos \theta_0 \hat{\mathbf{k}}) \\ &= \mu_E (-0.062 \hat{\mathbf{i}} + 0.18 \hat{\mathbf{j}} - 0.98 \hat{\mathbf{k}}) \end{aligned} \tag{9.5.7}$$

where $\mu_E = 7.79 \times 10^{22} \text{ A} \cdot \text{m}^2$, and we have used $(\theta_0, \phi_0) = (169^\circ, 109^\circ)$. The expression shows that $\bar{\mu}_E$ has non-vanishing components in all three directions in the Cartesian coordinates.

On the other hand, the location of MIT is 42°N for the latitude and 71°W for the longitude (42° north of the equator, and 71° west of the prime meridian), which means that $\theta_m = 90^\circ - 42^\circ = 48^\circ$, and $\phi_m = 360^\circ - 71^\circ = 289^\circ$. Thus, the position of MIT can be described by the vector

$$\begin{aligned}\bar{\mathbf{r}}_{\text{MIT}} &= r_E (\sin \theta_m \cos \phi_m \hat{\mathbf{i}} + \sin \theta_m \sin \phi_m \hat{\mathbf{j}} + \cos \theta_m \hat{\mathbf{k}}) \\ &= r_E (0.24 \hat{\mathbf{i}} - 0.70 \hat{\mathbf{j}} + 0.67 \hat{\mathbf{k}})\end{aligned}\quad (9.5.8)$$

The angle between $-\bar{\mu}_E$ and $\bar{\mathbf{r}}_{\text{MIT}}$ is given by

$$\theta_{ME} = \cos^{-1} \left(\frac{-\bar{\mathbf{r}}_{\text{MIT}} \cdot \bar{\mu}_E}{|\bar{\mathbf{r}}_{\text{MIT}}| |-\bar{\mu}_E|} \right) = \cos^{-1}(0.80) = 37^\circ \quad (9.5.9)$$

Note that the polar angle θ is defined as $\theta = \cos^{-1}(\hat{\mathbf{r}} \cdot \hat{\mathbf{k}})$, the inverse of cosine of the dot product between a unit vector $\hat{\mathbf{r}}$ for the position, and a unit vector $+\hat{\mathbf{k}}$ in the *positive* z -direction, as indicated in Figure 9.6.1. Thus, if we measure the ratio of the radial to the polar component of the Earth's magnetic field at MIT, the result would be

$$\boxed{\frac{B_r}{B_\theta} = 2 \cot 37^\circ \approx 2.65} \quad (9.5.10)$$

Note that the positive radial (vertical) direction is chosen to point outward and the positive polar (horizontal) direction points towards the equator.

Animation 9.4: Bar Magnet in the Earth's Magnetic Field

Figure 9.5.4 shows a bar magnet and compass placed on a table. The interaction between the magnetic field of the bar magnet and the magnetic field of the earth is illustrated by the field lines that extend out from the bar magnet. Field lines that emerge towards the edges of the magnet generally reconnect to the magnet near the opposite pole. However, field lines that emerge near the poles tend to wander off and reconnect to the magnetic field of the earth, which, in this case, is approximately a constant field coming at 60 degrees from the horizontal. Looking at the compass, one can see that a compass needle will always align itself in the direction of the local field. In this case, the local field is dominated by the bar magnet.

Click and drag the mouse to rotate the scene. Control-click and drag to zoom in and out.

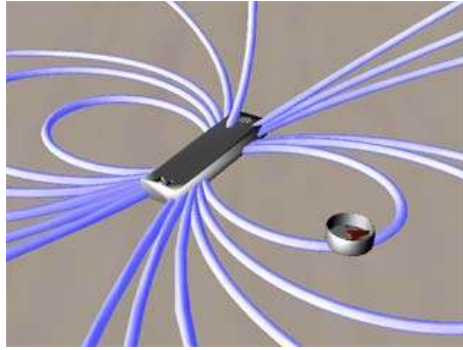

Figure 9.5.4 A bar magnet in Earth's magnetic field

9.6 Magnetic Materials

The introduction of material media into the study of magnetism has very different consequences as compared to the introduction of material media into the study of electrostatics. When we dealt with dielectric materials in electrostatics, their effect was *always* to reduce \vec{E} below what it would otherwise be, for a given amount of "free" electric charge. In contrast, when we deal with magnetic materials, their effect can be one of the following:

- (i) reduce \vec{B} below what it would otherwise be, for the same amount of "free" electric current (*diamagnetic* materials);
- (ii) increase \vec{B} a little above what it would otherwise be (*paramagnetic* materials);
- (iii) increase \vec{B} *a lot* above what it would otherwise be (*ferromagnetic* materials).

Below we discuss how these effects arise.

9.6.1 Magnetization

Magnetic materials consist of many permanent or induced magnetic dipoles. One of the concepts crucial to the understanding of magnetic materials is the average magnetic field produced by many magnetic dipoles which are all aligned. Suppose we have a piece of material in the form of a long cylinder with area A and height L , and that it consists of N magnetic dipoles, each with magnetic dipole moment $\vec{\mu}$, spread uniformly throughout the volume of the cylinder, as shown in Figure 9.6.1.

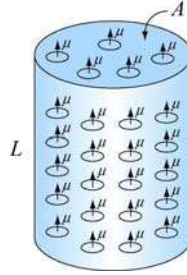

Figure 9.6.1 A cylinder with N magnetic dipole moments

We also assume that all of the magnetic dipole moments $\vec{\mu}$ are aligned with the axis of the cylinder. In the absence of any external magnetic field, what is the average magnetic field due to these dipoles alone?

To answer this question, we note that each magnetic dipole has its own magnetic field associated with it. Let's define the magnetization vector \vec{M} to be the net magnetic dipole moment vector per unit volume:

$$\vec{M} = \frac{1}{V} \sum_i \vec{\mu}_i \quad (9.6.1)$$

where V is the volume. In the case of our cylinder, where all the dipoles are aligned, the magnitude of \vec{M} is simply $M = N\mu / AL$.

Now, what is the average magnetic field produced by all the dipoles in the cylinder?

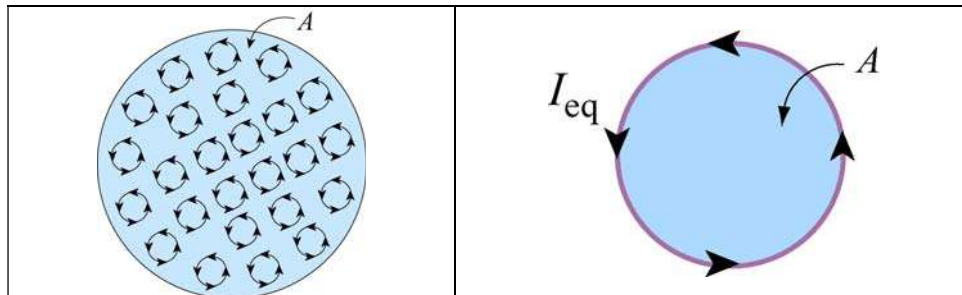

Figure 9.6.2 (a) Top view of the cylinder containing magnetic dipole moments. (b) The equivalent current.

Figure 9.6.2(a) depicts the small current loops associated with the dipole moments and the direction of the currents, as seen from above. We see that in the interior, currents flow in a given direction will be cancelled out by currents flowing in the opposite direction in neighboring loops. The only place where cancellation does not take place is near the edge of the cylinder where there are no adjacent loops further out. Thus, the average current in the interior of the cylinder vanishes, whereas the sides of the cylinder appear to carry a net current. The equivalent situation is shown in Figure 9.6.2(b), where there is an equivalent current I_{eq} on the sides.

The functional form of I_{eq} may be deduced by requiring that the magnetic dipole moment produced by I_{eq} be the same as total magnetic dipole moment of the system. The condition gives

$$I_{\text{eq}}A = N\mu \quad (9.6.2)$$

or

$$I_{\text{eq}} = \frac{N\mu}{A} \quad (9.6.3)$$

Next, let's calculate the magnetic field produced by I_{eq} . With I_{eq} running on the sides, the equivalent configuration is identical to a solenoid carrying a surface current (or current per unit length) K . The two quantities are related by

$$K = \frac{I_{\text{eq}}}{L} = \frac{N\mu}{AL} = M \quad (9.6.4)$$

Thus, we see that the surface current K is equal to the magnetization M , which is the average magnetic dipole moment per unit volume. The average magnetic field produced by the equivalent current system is given by (see Section 9.4)

$$B_M = \mu_0 K = \mu_0 M \quad (9.6.5)$$

Since the direction of this magnetic field is in the *same* direction as \vec{M} , the above expression may be written in vector notation as

$$\vec{B}_M = \mu_0 \vec{M} \quad (9.6.6)$$

This is exactly opposite from the situation with electric dipoles, in which the average electric field is anti-parallel to the direction of the electric dipoles themselves. The reason is that in the region interior to the current loop of the dipole, the magnetic field is in the *same* direction as the magnetic dipole vector. Therefore, it is not surprising that after a large-scale averaging, the average magnetic field also turns out to be parallel to the average magnetic dipole moment per unit volume.

Notice that the magnetic field in Eq. (9.6.6) is the *average* field due to all the dipoles. A very different field is observed if we go close to any one of these little dipoles.

Let's now examine the properties of different magnetic materials

9.6.2 Paramagnetism

The atoms or molecules comprising paramagnetic materials have a permanent magnetic dipole moment. Left to themselves, the permanent magnetic dipoles in a paramagnetic material never line up spontaneously. In the absence of any applied external magnetic field, they are randomly aligned. Thus, $\vec{\mathbf{M}} = \vec{\mathbf{0}}$ and the average magnetic field $\vec{\mathbf{B}}_M$ is also zero. However, when we place a paramagnetic material in an external field $\vec{\mathbf{B}}_0$, the dipoles experience a torque $\vec{\mathbf{\tau}} = \vec{\mathbf{\mu}} \times \vec{\mathbf{B}}_0$ that tends to align $\vec{\mathbf{\mu}}$ with $\vec{\mathbf{B}}_0$, thereby producing a net magnetization $\vec{\mathbf{M}}$ parallel to $\vec{\mathbf{B}}_0$. Since $\vec{\mathbf{B}}_M$ is parallel to $\vec{\mathbf{B}}_0$, it will tend to *enhance* $\vec{\mathbf{B}}_0$. The total magnetic field $\vec{\mathbf{B}}$ is the sum of these two fields:

$$\vec{\mathbf{B}} = \vec{\mathbf{B}}_0 + \vec{\mathbf{B}}_M = \vec{\mathbf{B}}_0 + \mu_0 \vec{\mathbf{M}} \quad (9.6.7)$$

Note how different this is than in the case of dielectric materials. In both cases, the torque on the dipoles causes alignment of the dipole vector parallel to the external field. However, in the paramagnetic case, that alignment *enhances* the external magnetic field, whereas in the dielectric case it *reduces* the external electric field. In most paramagnetic substances, the magnetization $\vec{\mathbf{M}}$ is not only in the same direction as $\vec{\mathbf{B}}_0$, but also linearly proportional to $\vec{\mathbf{B}}_0$. This is plausible because without the external field $\vec{\mathbf{B}}_0$ there would be no alignment of dipoles and hence no magnetization $\vec{\mathbf{M}}$. The linear relation between $\vec{\mathbf{M}}$ and $\vec{\mathbf{B}}_0$ is expressed as

$$\vec{\mathbf{M}} = \chi_m \frac{\vec{\mathbf{B}}_0}{\mu_0} \quad (9.6.8)$$

where χ_m is a dimensionless quantity called the *magnetic susceptibility*. Eq. (10.7.7) can then be written as

$$\vec{\mathbf{B}} = (1 + \chi_m) \vec{\mathbf{B}}_0 = \kappa_m \vec{\mathbf{B}}_0 \quad (9.6.9)$$

where

$$\kappa_m = 1 + \chi_m \quad (9.6.10)$$

is called the *relative permeability* of the material. For paramagnetic substances, $\kappa_m > 1$, or equivalently, $\chi_m > 0$, although χ_m is usually on the order of 10^{-6} to 10^{-3} . The *magnetic permeability* μ_m of a material may also be defined as

$$\mu_m = (1 + \chi_m) \mu_0 = \kappa_m \mu_0 \quad (9.6.11)$$

Paramagnetic materials have $\mu_m > \mu_0$.

9.6.3 Diamagnetism

In the case of magnetic materials where there are no permanent magnetic dipoles, the presence of an external field \vec{B}_0 will induce magnetic dipole moments in the atoms or molecules. However, these induced magnetic dipoles are anti-parallel to \vec{B}_0 , leading to a magnetization \vec{M} and average field \vec{B}_M anti-parallel to \vec{B}_0 , and therefore a *reduction* in the total magnetic field strength. For diamagnetic materials, we can still define the magnetic permeability, as in equation (8-5), although now $\kappa_m < 1$, or $\chi_m < 0$, although χ_m is usually on the order of -10^{-5} to -10^{-9} . Diamagnetic materials have $\mu_m < \mu_0$.

9.6.4 Ferromagnetism

In ferromagnetic materials, there is a strong interaction between neighboring atomic dipole moments. Ferromagnetic materials are made up of small patches called *domains*, as illustrated in Figure 9.6.3(a). An externally applied field \vec{B}_0 will tend to line up those magnetic dipoles parallel to the external field, as shown in Figure 9.6.3(b). The strong interaction between neighboring atomic dipole moments causes a *much stronger* alignment of the magnetic dipoles than in paramagnetic materials.

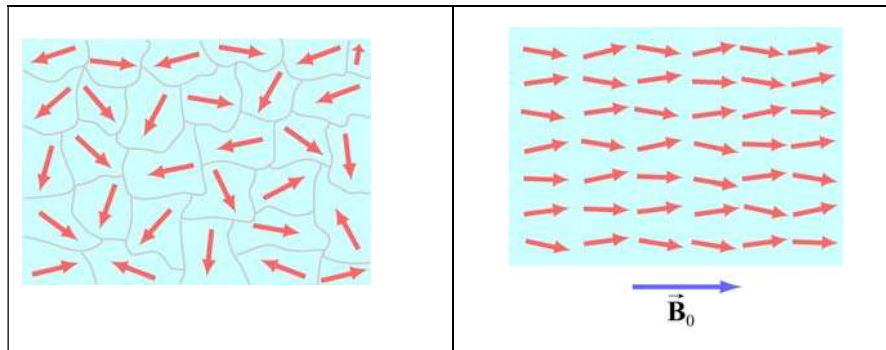

Figure 9.6.3 (a) Ferromagnetic domains. (b) Alignment of magnetic moments in the direction of the external field \vec{B}_0 .

The enhancement of the applied external field can be considerable, with the total magnetic field inside a ferromagnet 10^3 or 10^4 times greater than the applied field. The permeability κ_m of a ferromagnetic material is not a constant, since neither the total field \vec{B} or the magnetization \vec{M} increases linearly with \vec{B}_0 . In fact the relationship between \vec{M} and \vec{B}_0 is not unique, but dependent on the previous history of the material. The

phenomenon is known as *hysteresis*. The variation of \vec{M} as a function of the externally applied field \vec{B}_0 is shown in Figure 9.6.4. The loop *abcdef* is a *hysteresis curve*.

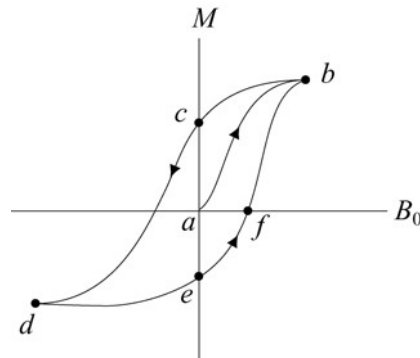

Figure 9.6.4 A hysteresis curve.

Moreover, in ferromagnets, the strong interaction between neighboring atomic dipole moments can keep those dipole moments aligned, even when the external magnet field is reduced to zero. And these aligned dipoles can thus produce a strong magnetic field, all by themselves, without the necessity of an external magnetic field. This is the origin of permanent magnets. To see how strong such magnets can be, consider the fact that magnetic dipole moments of atoms typically have magnitudes of the order of $10^{-23} \text{ A} \cdot \text{m}^2$. Typical atomic densities are $10^{29} \text{ atoms/m}^3$. If all these dipole moments are aligned, then we would get a magnetization of order

$$M \sim (10^{-23} \text{ A} \cdot \text{m}^2)(10^{29} \text{ atoms/m}^3) \sim 10^6 \text{ A/m} \quad (9.6.12)$$

The magnetization corresponds to values of $\vec{B}_M = \mu_0 \vec{M}$ of order 1 tesla, or 10,000 Gauss, just due to the atomic currents alone. This is how we get permanent magnets with fields of order 2200 Gauss.

9.7 Summary

- **Biot-Savart law** states that the magnetic field $d\vec{B}$ at a point due to a length element $d\vec{s}$ carrying a steady current I and located at \vec{r} away is given by

$$d\vec{B} = \frac{\mu_0}{4\pi} \frac{I d\vec{s} \times \hat{r}}{r^2}$$

where $r = |\vec{r}|$ and $\mu_0 = 4\pi \times 10^{-7} \text{ T} \cdot \text{m/A}$ is the permeability of free space.

- The magnitude of the magnetic field at a distance r away from an infinitely long straight wire carrying a current I is

$$B = \frac{\mu_0 I}{2\pi r}$$

- The magnitude of the magnetic force F_B between two straight wires of length ℓ carrying steady current of I_1 and I_2 and separated by a distance r is

$$F_B = \frac{\mu_0 I_1 I_2 \ell}{2\pi r}$$

- Ampere's law** states that the line integral of $\vec{\mathbf{B}} \cdot d\vec{\mathbf{s}}$ around any closed loop is proportional to the total steady current passing through any surface that is bounded by the close loop:

$$\oint \vec{\mathbf{B}} \cdot d\vec{\mathbf{s}} = \mu_0 I_{\text{enc}}$$

- The magnetic field inside a **toroid** which has N closely spaced of wire carrying a current I is given by

$$B = \frac{\mu_0 NI}{2\pi r}$$

where r is the distance from the center of the toroid.

- The magnetic field inside a **solenoid** which has N closely spaced of wire carrying current I in a length of l is given by

$$B = \mu_0 \frac{N}{l} I = \mu_0 n I$$

where n is the number of number of turns per unit length.

- The properties of magnetic materials are as follows:

Materials	Magnetic susceptibility χ_m	Relative permeability $\kappa_m = 1 + \chi_m$	Magnetic permeability $\mu_m = \kappa_m \mu_0$
Diamagnetic	$-10^{-5} \sim -10^{-9}$	$\kappa_m < 1$	$\mu_m < \mu_0$
Paramagnetic	$10^{-5} \sim 10^{-3}$	$\kappa_m > 1$	$\mu_m > \mu_0$
Ferromagnetic	$\chi_m \gg 1$	$\kappa_m \gg 1$	$\mu_m \gg \mu_0$

9.8 Appendix 1: Magnetic Field off the Symmetry Axis of a Current Loop

In Example 9.2 we calculated the magnetic field due to a circular loop of radius R lying in the xy plane and carrying a steady current I , at a point P along the axis of symmetry. Let's see how the same technique can be extended to calculating the field at a point off the axis of symmetry in the yz plane.

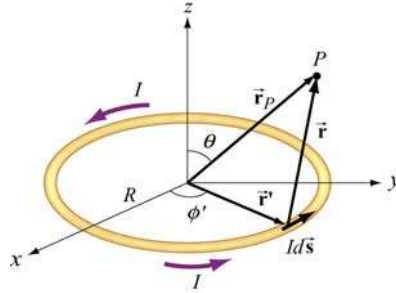

Figure 9.8.1 Calculating the magnetic field off the symmetry axis of a current loop.

Again, as shown in Example 9.1, the differential current element is

$$Id\vec{s} = R d\phi'(-\sin\phi'\hat{\mathbf{i}} + \cos\phi'\hat{\mathbf{j}})$$

and its position is described by $\vec{r}' = R(\cos\phi'\hat{\mathbf{i}} + \sin\phi'\hat{\mathbf{j}})$. On the other hand, the field point P now lies in the yz plane with $\vec{r}_p = y\hat{\mathbf{j}} + z\hat{\mathbf{k}}$, as shown in Figure 9.8.1. The corresponding relative position vector is

$$\vec{r} = \vec{r}_p - \vec{r}' = -R\cos\phi'\hat{\mathbf{i}} + (y - R\sin\phi')\hat{\mathbf{j}} + z\hat{\mathbf{k}} \quad (9.8.1)$$

with a magnitude

$$r = |\vec{r}| = \sqrt{(-R\cos\phi')^2 + (y - R\sin\phi')^2 + z^2} = \sqrt{R^2 + y^2 + z^2 - 2yR\sin\phi} \quad (9.8.2)$$

and the unit vector

$$\hat{\mathbf{r}} = \frac{\vec{r}}{r} = \frac{\vec{r}_p - \vec{r}'}{|\vec{r}_p - \vec{r}'|}$$

pointing from $Id\vec{s}$ to P . The cross product $d\vec{s} \times \hat{\mathbf{r}}$ can be simplified as

$$\begin{aligned} d\vec{s} \times \hat{\mathbf{r}} &= R d\phi'(-\sin\phi'\hat{\mathbf{i}} + \cos\phi'\hat{\mathbf{j}}) \times [-R\cos\phi'\hat{\mathbf{i}} + (y - R\sin\phi')\hat{\mathbf{j}} + z\hat{\mathbf{k}}] \\ &= R d\phi'[z\cos\phi'\hat{\mathbf{i}} + z\sin\phi'\hat{\mathbf{j}} + (R - y\sin\phi')\hat{\mathbf{k}}] \end{aligned} \quad (9.8.3)$$

Using the Biot-Savart law, the contribution of the current element to the magnetic field at P is

$$d\vec{\mathbf{B}} = \frac{\mu_0 I}{4\pi} \frac{d\vec{\mathbf{s}} \times \hat{\mathbf{r}}}{r^2} = \frac{\mu_0 I}{4\pi} \frac{d\vec{\mathbf{s}} \times \vec{\mathbf{r}}}{r^3} = \frac{\mu_0 IR}{4\pi} \frac{z \cos \phi' \hat{\mathbf{i}} + z \sin \phi' \hat{\mathbf{j}} + (R - y \sin \phi') \hat{\mathbf{k}}}{(R^2 + y^2 + z^2 - 2yR \sin \phi')^{3/2}} d\phi' \quad (9.8.4)$$

Thus, magnetic field at P is

$$\vec{\mathbf{B}}(0, y, z) = \frac{\mu_0 IR}{4\pi} \int_0^{2\pi} \frac{z \cos \phi' \hat{\mathbf{i}} + z \sin \phi' \hat{\mathbf{j}} + (R - y \sin \phi') \hat{\mathbf{k}}}{(R^2 + y^2 + z^2 - 2yR \sin \phi')^{3/2}} d\phi' \quad (9.8.5)$$

The x -component of $\vec{\mathbf{B}}$ can be readily shown to be zero

$$B_x = \frac{\mu_0 IRz}{4\pi} \int_0^{2\pi} \frac{\cos \phi' d\phi'}{(R^2 + y^2 + z^2 - 2yR \sin \phi')^{3/2}} = 0 \quad (9.8.6)$$

by making a change of variable $w = R^2 + y^2 + z^2 - 2yR \sin \phi'$, followed by a straightforward integration. One may also invoke symmetry arguments to verify that B_x must vanish; namely, the contribution at ϕ' is cancelled by the contribution at $\pi - \phi'$. On the other hand, the y and the z components of $\vec{\mathbf{B}}$,

$$B_y = \frac{\mu_0 IRz}{4\pi} \int_0^{2\pi} \frac{\sin \phi' d\phi'}{(R^2 + y^2 + z^2 - 2yR \sin \phi')^{3/2}} \quad (9.8.7)$$

and

$$B_z = \frac{\mu_0 IR}{4\pi} \int_0^{2\pi} \frac{(R - y \sin \phi') d\phi'}{(R^2 + y^2 + z^2 - 2yR \sin \phi')^{3/2}} \quad (9.8.8)$$

involve *elliptic integrals* which can be evaluated numerically.

In the limit $y = 0$, the field point P is located along the z -axis, and we recover the results obtained in Example 9.2:

$$B_y = \frac{\mu_0 IRz}{4\pi(R^2 + z^2)^{3/2}} \int_0^{2\pi} \sin \phi' d\phi' = -\frac{\mu_0 IRz}{4\pi(R^2 + z^2)^{3/2}} \cos \phi' \Big|_0^{2\pi} = 0 \quad (9.8.9)$$

and

$$B_z = \frac{\mu_0}{4\pi} \frac{IR^2}{(R^2 + z^2)^{3/2}} \int_0^{2\pi} d\phi' = \frac{\mu_0}{4\pi} \frac{2\pi IR^2}{(R^2 + z^2)^{3/2}} = \frac{\mu_0 IR^2}{2(R^2 + z^2)^{3/2}} \quad (9.8.10)$$

Now, let's consider the "point-dipole" limit where $R \ll (y^2 + z^2)^{1/2} = r$, i.e., the characteristic dimension of the current source is much smaller compared to the distance where the magnetic field is to be measured. In this limit, the denominator in the integrand can be expanded as

$$\begin{aligned} (R^2 + y^2 + z^2 - 2yR \sin \phi')^{-3/2} &= \frac{1}{r^3} \left[1 + \frac{R^2 - 2yR \sin \phi'}{r^2} \right]^{-3/2} \\ &= \frac{1}{r^3} \left[1 - \frac{3}{2} \left(\frac{R^2 - 2yR \sin \phi'}{r^2} \right) + \dots \right] \end{aligned} \quad (9.8.11)$$

This leads to

$$\begin{aligned} B_y &\approx \frac{\mu_0 I}{4\pi} \frac{Rz}{r^3} \int_0^{2\pi} \left[1 - \frac{3}{2} \left(\frac{R^2 - 2yR \sin \phi'}{r^2} \right) \right] \sin \phi' d\phi' \\ &= \frac{\mu_0 I}{4\pi} \frac{3R^2 yz}{r^5} \int_0^{2\pi} \sin^2 \phi' d\phi' = \frac{\mu_0 I}{4\pi} \frac{3\pi R^2 yz}{r^5} \end{aligned} \quad (9.8.12)$$

and

$$\begin{aligned} B_z &\approx \frac{\mu_0 I}{4\pi} \frac{R}{r^3} \int_0^{2\pi} \left[1 - \frac{3}{2} \left(\frac{R^2 - 2yR \sin \phi'}{r^2} \right) \right] (R - y \sin \phi') d\phi' \\ &= \frac{\mu_0 I}{4\pi} \frac{R}{r^3} \int_0^{2\pi} \left[\left(R - \frac{3R^3}{2r^2} \right) - \left(1 - \frac{9R^2}{2r^2} \right) \sin \phi' - \frac{3Ry^2}{r^2} \sin^2 \phi' \right] d\phi' \\ &= \frac{\mu_0 I}{4\pi} \frac{R}{r^3} \left[2\pi \left(R - \frac{3R^3}{2r^2} \right) - \frac{3\pi Ry^2}{r^2} \right] \\ &= \frac{\mu_0 I}{4\pi} \frac{\pi R^2}{r^3} \left[2 - \frac{3y^2}{r^2} + \text{higher order terms} \right] \end{aligned} \quad (9.8.13)$$

The quantity $I(\pi R^2)$ may be identified as the magnetic dipole moment $\mu = IA$, where $A = \pi R^2$ is the area of the loop. Using spherical coordinates where $y = r \sin \theta$ and $z = r \cos \theta$, the above expressions may be rewritten as

$$B_y = \frac{\mu_0 (I\pi R^2)}{4\pi} \frac{3(r \sin \theta)(r \cos \theta)}{r^5} = \frac{\mu_0}{4\pi} \frac{3\mu \sin \theta \cos \theta}{r^3} \quad (9.8.14)$$

and

$$B_z = \frac{\mu_0}{4\pi} \frac{(I\pi R^2)}{r^3} \left(2 - \frac{3r^2 \sin^2 \theta}{r^2} \right) = \frac{\mu_0}{4\pi} \frac{\mu}{r^3} (2 - 3\sin^2 \theta) = \frac{\mu_0}{4\pi} \frac{\mu}{r^3} (3\cos^2 \theta - 1) \quad (9.8.15)$$

Thus, we see that the magnetic field at a point $r \gg R$ due to a current ring of radius R may be approximated by a small magnetic dipole moment placed at the origin (Figure 9.8.2).

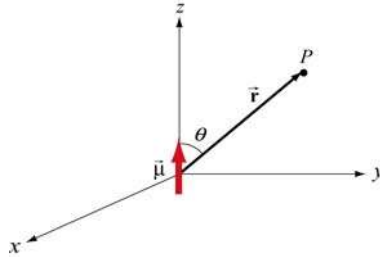

Figure 9.8.2 Magnetic dipole moment $\vec{\mu} = \mu \hat{\mathbf{k}}$

The magnetic field lines due to a current loop and a dipole moment (small bar magnet) are depicted in Figure 9.8.3.

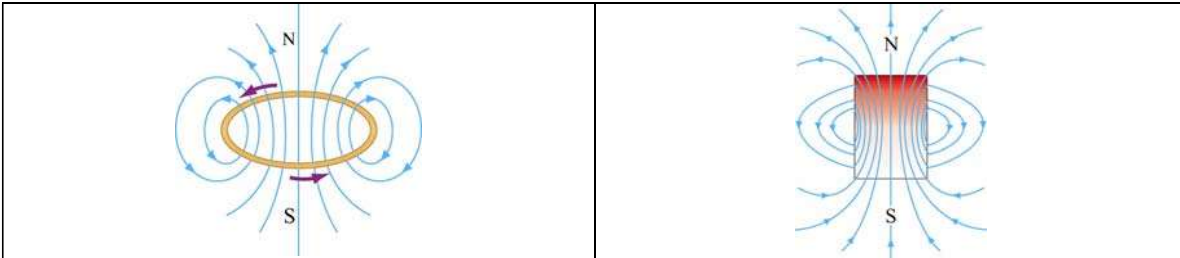

Figure 9.8.3 Magnetic field lines due to (a) a current loop, and (b) a small bar magnet.

The magnetic field at P can also be written in spherical coordinates

$$\vec{\mathbf{B}} = B_r \hat{\mathbf{r}} + B_\theta \hat{\boldsymbol{\theta}} \quad (9.8.16)$$

The spherical components B_r and B_θ are related to the Cartesian components B_y and B_z by

$$B_r = B_y \sin \theta + B_z \cos \theta, \quad B_\theta = B_y \cos \theta - B_z \sin \theta \quad (9.8.17)$$

In addition, we have, for the unit vectors,

$$\hat{\mathbf{r}} = \sin \theta \hat{\mathbf{j}} + \cos \theta \hat{\mathbf{k}}, \quad \hat{\boldsymbol{\theta}} = \cos \theta \hat{\mathbf{j}} - \sin \theta \hat{\mathbf{k}} \quad (9.8.18)$$

Using the above relations, the spherical components may be written as

$$B_r = \frac{\mu_0 IR^2 \cos \theta}{4\pi} \int_0^{2\pi} \frac{d\phi'}{(R^2 + r^2 - 2rR \sin \theta \sin \phi')^{3/2}} \quad (9.8.19)$$

and

$$B_\theta(r, \theta) = \frac{\mu_0 IR}{4\pi} \int_0^{2\pi} \frac{(r \sin \phi' - R \sin \theta) d\phi'}{(R^2 + r^2 - 2rR \sin \theta \sin \phi')^{3/2}} \quad (9.8.20)$$

In the limit where $R \ll r$, we obtain

$$B_r \approx \frac{\mu_0 IR^2 \cos \theta}{4\pi r^3} \int_0^{2\pi} d\phi' = \frac{\mu_0}{4\pi} \frac{2\pi IR^2 \cos \theta}{r^3} = \frac{\mu_0}{4\pi} \frac{2\mu \cos \theta}{r^3} \quad (9.8.21)$$

and

$$\begin{aligned} B_\theta &= \frac{\mu_0 IR}{4\pi} \int_0^{2\pi} \frac{(r \sin \phi' - R \sin \theta) d\phi'}{(R^2 + r^2 - 2rR \sin \theta \sin \phi')^{3/2}} \\ &\approx \frac{\mu_0 IR}{4\pi r^3} \int_0^{2\pi} \left[-R \sin \theta \left(1 - \frac{3R^2}{2r^2} \right) + \left(r - \frac{3R^2}{2r} - \frac{3R^2 \sin^2 \theta}{2r} \right) \sin \phi' + 3R \sin \theta \sin^2 \phi' \right] d\phi' \\ &\approx \frac{\mu_0 IR}{4\pi r^3} (-2\pi R \sin \theta + 3\pi R \sin \theta) = \frac{\mu_0 (I\pi R^2) \sin \theta}{4\pi r^3} \\ &= \frac{\mu_0}{4\pi} \frac{\mu \sin \theta}{r^3} \end{aligned} \quad (9.8.22)$$

9.9 Appendix 2: Helmholtz Coils

Consider two N -turn circular coils of radius R , each perpendicular to the axis of symmetry, with their centers located at $z = \pm l/2$. There is a steady current I flowing in the same direction around each coil, as shown in Figure 9.9.1. Let's find the magnetic field $\vec{\mathbf{B}}$ on the axis at a distance z from the center of one coil.

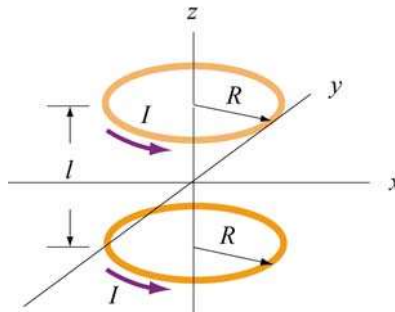

Figure 9.9.1 Helmholtz coils

Using the result shown in Example 9.2 for a single coil and applying the superposition principle, the magnetic field at $P(z,0)$ (a point at a distance $z-l/2$ away from one center and $z+l/2$ from the other) due to the two coils can be obtained as:

$$B_z = B_{\text{top}} + B_{\text{bottom}} = \frac{\mu_0 N I R^2}{2} \left[\frac{1}{[(z-l/2)^2 + R^2]^{3/2}} + \frac{1}{[(z+l/2)^2 + R^2]^{3/2}} \right] \quad (9.9.1)$$

A plot of B_z/B_0 with $B_0 = \frac{\mu_0 N I}{(5/4)^{3/2} R}$ being the field strength at $z=0$ and $l=R$ is depicted in Figure 9.9.2.

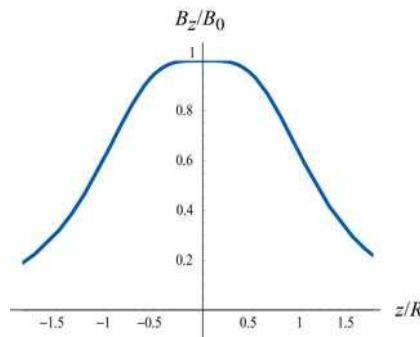

Figure 9.9.2 Magnetic field as a function of z/R .

Let's analyze the properties of B_z in more detail. Differentiating B_z with respect to z , we obtain

$$B'_z(z) = \frac{dB_z}{dz} = \frac{\mu_0 N I R^2}{2} \left\{ -\frac{3(z-l/2)}{[(z-l/2)^2 + R^2]^{5/2}} - \frac{3(z+l/2)}{[(z+l/2)^2 + R^2]^{5/2}} \right\} \quad (9.9.2)$$

One may readily show that at the midpoint, $z=0$, the derivative vanishes:

$$\left. \frac{dB}{dz} \right|_{z=0} = 0 \quad (9.9.3)$$

Straightforward differentiation yields

$$B''_z(z) = \frac{d^2 B}{dz^2} = \frac{N \mu_0 I R^2}{2} \left\{ -\frac{3}{[(z-l/2)^2 + R^2]^{5/2}} + \frac{15(z-l/2)^2}{[(z-l/2)^2 + R^2]^{7/2}} - \frac{3}{[(z+l/2)^2 + R^2]^{5/2}} + \frac{15(z+l/2)^2}{[(z+l/2)^2 + R^2]^{7/2}} \right\} \quad (9.9.4)$$

At the midpoint $z = 0$, the above expression simplifies to

$$\begin{aligned}
 B_z''(0) &= \left. \frac{d^2 B}{dz^2} \right|_{z=0} = \frac{\mu_0 N I^2}{2} \left\{ -\frac{6}{[(l/2)^2 + R^2]^{5/2}} + \frac{15l^2}{2[(l/2)^2 + R^2]^{7/2}} \right\} \\
 &= -\frac{\mu_0 N I^2}{2} \frac{6(R^2 - l^2)}{[(l/2)^2 + R^2]^{7/2}}
 \end{aligned} \tag{9.9.5}$$

Thus, the condition that the second derivative of B_z vanishes at $z = 0$ is $l = R$. That is, the distance of separation between the two coils is equal to the radius of the coil. A configuration with $l = R$ is known as *Helmholtz coils*.

For small z , we may make a Taylor-series expansion of $B_z(z)$ about $z = 0$:

$$B_z(z) = B_z(0) + B_z'(0)z + \frac{1}{2!} B_z''(0)z^2 + \dots \tag{9.9.6}$$

The fact that the first two derivatives vanish at $z = 0$ indicates that the magnetic field is fairly uniform in the small z region. One may even show that the third derivative $B_z'''(0)$ vanishes at $z = 0$ as well.

Recall that the force experienced by a dipole in a magnetic field is $\vec{\mathbf{F}}_B = \nabla(\vec{\mu} \cdot \vec{\mathbf{B}})$. If we place a magnetic dipole $\vec{\mu} = \mu_z \hat{\mathbf{k}}$ at $z = 0$, the magnetic force acting on the dipole is

$$\vec{\mathbf{F}}_B = \nabla(\mu_z B_z) = \mu_z \left(\frac{dB_z}{dz} \right) \hat{\mathbf{k}} \tag{9.9.7}$$

which is expected to be very small since the magnetic field is nearly uniform there.

Animation 9.5: Magnetic Field of the Helmholtz Coils

The animation in Figure 9.9.3(a) shows the magnetic field of the Helmholtz coils. In this configuration the currents in the top and bottom coils flow in the same direction, with their dipole moments aligned. The magnetic fields from the two coils add up to create a net field that is nearly uniform at the center of the coils. Since the distance between the coils is equal to the radius of the coils and remains unchanged, the force of attraction between them creates a tension, and is illustrated by field lines stretching out to enclose both coils. When the distance between the coils is not fixed, as in the animation depicted in Figure 9.9.3(b), the two coils move toward each other due to their force of attraction. In this animation, the top loop has only half the current as the bottom loop. The field configuration is shown using the “iron filings” representation.

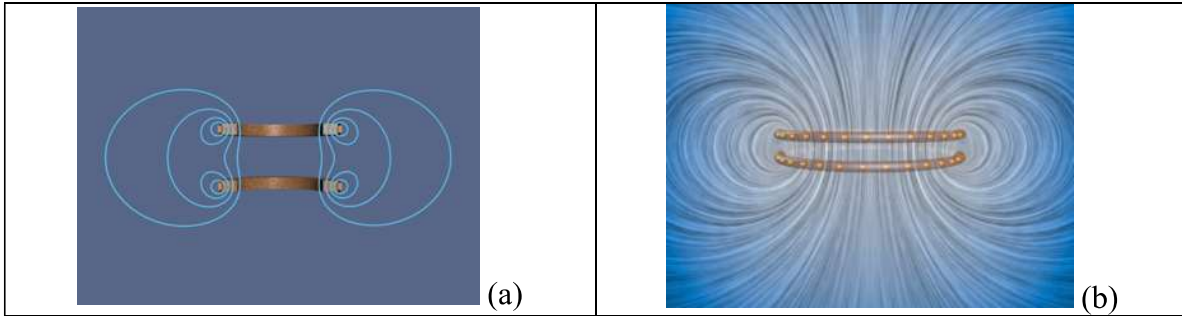

Figure 9.9.3 (a) Magnetic field of the Helmholtz coils where the distance between the coils is equal to the radius of the coil. (b) Two co-axial wire loops carrying current in the same sense are attracted to each other.

Next, let's consider the case where the currents in the loop flow in the opposite directions, as shown in Figure 9.9.4.

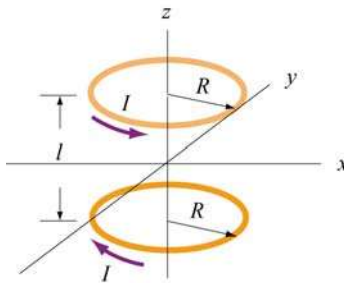

Figure 9.9.4 Two circular loops carrying currents in the opposite directions.

Again, by superposition principle, the magnetic field at a point $P(0, 0, z)$ with $z > 0$ is

$$B_z = B_{1z} + B_{2z} = \frac{\mu_0 N I R^2}{2} \left[\frac{1}{[(z-l/2)^2 + R^2]^{3/2}} - \frac{1}{[(z+l/2)^2 + R^2]^{3/2}} \right] \quad (9.9.8)$$

A plot of B_z / B_0 with $B_0 = \mu_0 N I / 2R$ and $l = R$ is depicted in Figure 9.9.5.

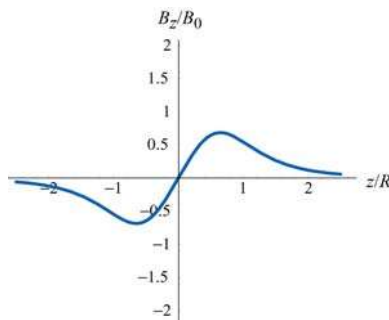

Figure 9.9.5 Magnetic field as a function of z / R .

Differentiating B_z with respect to z , we obtain

$$B'_z(z) = \frac{dB_z}{dz} = \frac{\mu_0 NIR^2}{2} \left\{ -\frac{3(z-l/2)}{[(z-l/2)^2 + R^2]^{5/2}} + \frac{3(z+l/2)}{[(z+l/2)^2 + R^2]^{5/2}} \right\} \quad (9.9.9)$$

At the midpoint, $z = 0$, we have

$$B'_z(0) = \left. \frac{dB_z}{dz} \right|_{z=0} = \frac{\mu_0 NIR^2}{2} \frac{3l}{[(l/2)^2 + R^2]^{5/2}} \neq 0 \quad (9.9.10)$$

Thus, a magnetic dipole $\vec{\mu} = \mu_z \hat{\mathbf{k}}$ placed at $z = 0$ will experience a net force:

$$\vec{\mathbf{F}}_B = \nabla(\vec{\mu} \cdot \vec{\mathbf{B}}) = \nabla(\mu_z B_z) = \mu_z \left(\frac{dB_z(0)}{dz} \right) \hat{\mathbf{k}} = \frac{\mu_z \mu_0 NIR^2}{2} \frac{3l}{[(l/2)^2 + R^2]^{5/2}} \hat{\mathbf{k}} \quad (9.9.11)$$

For $l = R$, the above expression simplifies to

$$\vec{\mathbf{F}}_B = \frac{3\mu_z \mu_0 NI}{2(5/4)^{5/2} R^2} \hat{\mathbf{k}} \quad (9.9.12)$$

Animation 9.6: Magnetic Field of Two Coils Carrying Opposite Currents

The animation depicted in Figure 9.9.6 shows the magnetic field of two coils like the Helmholtz coils but with currents in the top and bottom coils flowing in the opposite directions. In this configuration, the magnetic dipole moments associated with each coil are anti-parallel.

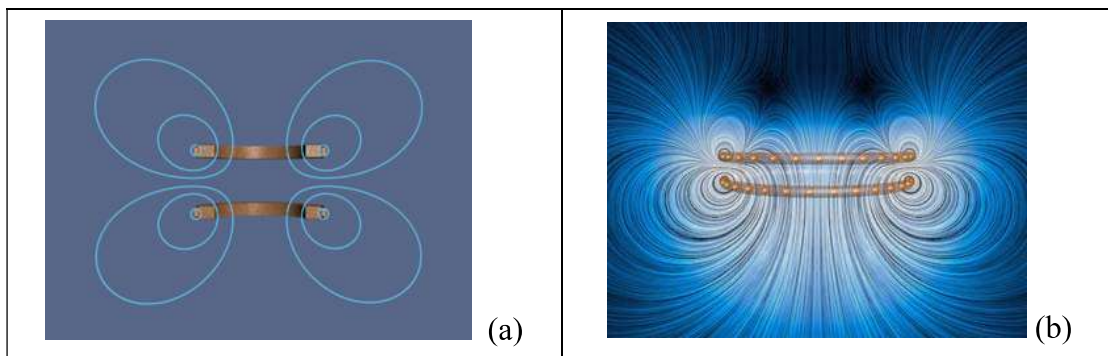

Figure 9.9.6 (a) Magnetic field due to coils carrying currents in the opposite directions. (b) Two co-axial wire loops carrying current in the opposite sense repel each other. The field configurations here are shown using the “iron filings” representation. The bottom wire loop carries twice the amount of current as the top wire loop.

At the center of the coils along the axis of symmetry, the magnetic field is zero. With the distance between the two coils fixed, the repulsive force results in a pressure between them. This is illustrated by field lines that are compressed along the central horizontal axis between the coils.

Animation 9.7: Forces Between Coaxial Current-Carrying Wires

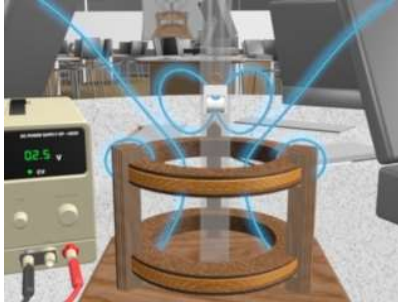

Figure 9.9.7 A magnet in the TeachSpin™ Magnetic Force apparatus when the current in the top coil is counterclockwise as seen from the top.

Figure 9.9.7 shows the force of repulsion between the magnetic field of a permanent magnet and the field of a current-carrying ring in the TeachSpin™ Magnetic Force apparatus. The magnet is forced to have its North magnetic pole pointing downward, and the current in the top coil of the Magnetic Force apparatus is moving clockwise as seen from above. The net result is a repulsion of the magnet when the current in this direction is increased. The visualization shows the stresses transmitted by the fields to the magnet when the current in the upper coil is increased.

Animation 9.8: Magnet Oscillating Between Two Coils

Figure 9.9.8 illustrates an animation in which the magnetic field of a permanent magnet suspended by a spring in the *TeachSpin*™ apparatus (see *TeachSpin* visualization), plus the magnetic field due to current in the two coils (here we see a "cutaway" cross-section of the apparatus).

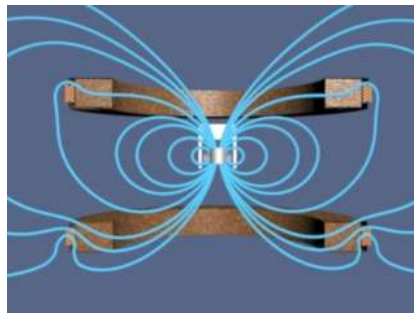

Figure 9.9.8 Magnet oscillating between two coils

The magnet is fixed so that its north pole points upward, and the current in the two coils is sinusoidal and 180 degrees out of phase. When the effective dipole moment of the top coil points upwards, the dipole moment of the bottom coil points downwards. Thus, the magnet is attracted to the upper coil and repelled by the lower coil, causing it to move upwards. When the conditions are reversed during the second half of the cycle, the magnet moves downwards.

This process can also be described in terms of tension along, and pressure perpendicular to, the field lines of the resulting field. When the dipole moment of one of the coils is aligned with that of the magnet, there is a tension along the field lines as they attempt to "connect" the coil and magnet. Conversely, when their moments are anti-aligned, there is a pressure perpendicular to the field lines as they try to keep the coil and magnet apart.

Animation 9.9: Magnet Suspended Between Two Coils

Figure 9.9.9 illustrates an animation in which the magnetic field of a permanent magnet suspended by a spring in the *TeachSpin*TM apparatus (see *TeachSpin* visualization), plus the magnetic field due to current in the two coils (here we see a "cutaway" cross-section of the apparatus). The magnet is fixed so that its north pole points upward, and the current in the two coils is sinusoidal and in phase. When the effective dipole moment of the top coil points upwards, the dipole moment of the bottom coil points upwards as well. Thus, the magnet the magnet is attracted to both coils, and as a result feels no net force (although it does feel a torque, not shown here since the direction of the magnet is fixed to point upwards). When the dipole moments are reversed during the second half of the cycle, the magnet is repelled by both coils, again resulting in no net force.

This process can also be described in terms of tension along, and pressure perpendicular to, the field lines of the resulting field. When the dipole moment of the coils is aligned with that of the magnet, there is a tension along the field lines as they are "pulled" from both sides. Conversely, when their moments are anti-aligned, there is a pressure perpendicular to the field lines as they are "squeezed" from both sides.

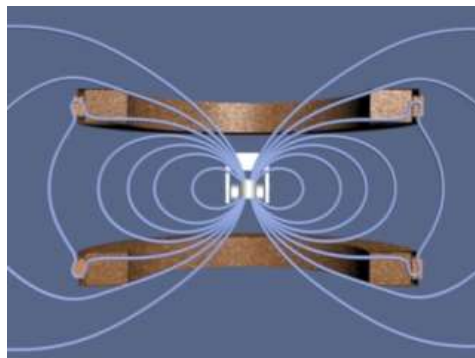

Figure 9.9.9 Magnet suspended between two coils

9.10 Problem-Solving Strategies

In this Chapter, we have seen how Biot-Savart and Ampere's laws can be used to calculate magnetic field due to a current source.

9.10.1 Biot-Savart Law:

The law states that the magnetic field at a point P due to a length element $d\vec{s}$ carrying a steady current I located at \vec{r} away is given by

$$d\vec{B} = \frac{\mu_0 I}{4\pi} \frac{d\vec{s} \times \hat{r}}{r^2} = \frac{\mu_0 I}{4\pi} \frac{d\vec{s} \times \vec{r}}{r^3}$$

The calculation of the magnetic field may be carried out as follows:

(1) Source point: Choose an appropriate coordinate system and write down an expression for the differential current element $I d\vec{s}$, and the vector \vec{r}' describing the position of $I d\vec{s}$. The magnitude $r' = |\vec{r}'|$ is the distance between $I d\vec{s}$ and the origin. Variables with a "prime" are used for the source point.

(2) Field point: The field point P is the point in space where the magnetic field due to the current distribution is to be calculated. Using the same coordinate system, write down the position vector \vec{r}_p for the field point P . The quantity $r_p = |\vec{r}_p|$ is the distance between the origin and P .

(3) Relative position vector: The relative position between the source point and the field point is characterized by the relative position vector $\vec{r} = \vec{r}_p - \vec{r}'$. The corresponding unit vector is

$$\hat{r} = \frac{\vec{r}}{r} = \frac{\vec{r}_p - \vec{r}'}{|\vec{r}_p - \vec{r}'|}$$

where $r = |\vec{r}| = |\vec{r}_p - \vec{r}'|$ is the distance between the source and the field point P .

(4) Calculate the cross product $d\vec{s} \times \hat{r}$ or $d\vec{s} \times \vec{r}$. The resultant vector gives the direction of the magnetic field \vec{B} , according to the Biot-Savart law.

(5) Substitute the expressions obtained to $d\vec{B}$ and simplify as much as possible.

(6) Complete the integration to obtain \vec{B} if possible. The size or the geometry of the system is reflected in the integration limits. Change of variables sometimes may help to complete the integration.

Below we illustrate how these steps are executed for a current-carrying wire of length L and a loop of radius R .

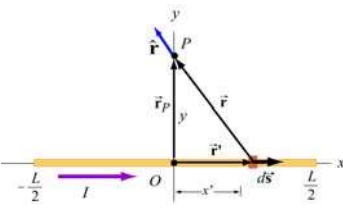
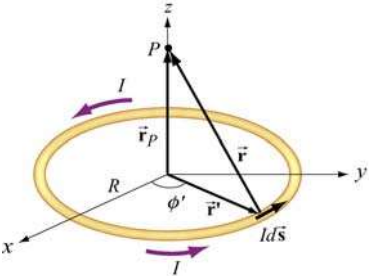
Current distribution	Finite wire of length L	Circular loop of radius R
Figure		
(1) Source point	$\vec{r}' = x' \hat{i}$ $d\vec{s} = (d\vec{r}' / dx') dx' = dx' \hat{i}$	$\vec{r}' = R(\cos \phi' \hat{i} + \sin \phi' \hat{j})$ $d\vec{s} = (d\vec{r}' / d\phi') d\phi' = R d\phi' (-\sin \phi' \hat{i} + \cos \phi' \hat{j})$
(2) Field point P	$\vec{r}_p = y \hat{j}$	$\vec{r}_p = z \hat{k}$
(3) Relative position vector $\vec{r} = \vec{r}_p - \vec{r}'$	$\vec{r} = y \hat{j} - x' \hat{i}$ $r = \vec{r} = \sqrt{x'^2 + y^2}$ $\hat{r} = \frac{y \hat{j} - x' \hat{i}}{\sqrt{x'^2 + y^2}}$	$\vec{r} = -R \cos \phi' \hat{i} - R \sin \phi' \hat{j} + z \hat{k}$ $r = \vec{r} = \sqrt{R^2 + z^2}$ $\hat{r} = \frac{-R \cos \phi' \hat{i} - R \sin \phi' \hat{j} + z \hat{k}}{\sqrt{R^2 + z^2}}$
(4) The cross product $d\vec{s} \times \hat{r}$	$d\vec{s} \times \hat{r} = \frac{y dx' \hat{k}}{\sqrt{y^2 + x'^2}}$	$d\vec{s} \times \hat{r} = \frac{R d\phi' (z \cos \phi' \hat{i} + z \sin \phi' \hat{j} + R \hat{k})}{\sqrt{R^2 + z^2}}$
(5) Rewrite $d\vec{B}$	$d\vec{B} = \frac{\mu_0 I}{4\pi} \frac{y dx' \hat{k}}{(y^2 + x'^2)^{3/2}}$	$d\vec{B} = \frac{\mu_0 I}{4\pi} \frac{R d\phi' (z \cos \phi' \hat{i} + z \sin \phi' \hat{j} + R \hat{k})}{(R^2 + z^2)^{3/2}}$
(6) Integrate to get \vec{B}	$B_x = 0$ $B_y = 0$ $B_z = \frac{\mu_0 I y}{4\pi} \int_{-L/2}^{L/2} \frac{dx'}{(y^2 + x'^2)^{3/2}}$ $= \frac{\mu_0 I}{4\pi} \frac{L}{y \sqrt{y^2 + (L/2)^2}}$	$B_x = \frac{\mu_0 I R z}{4\pi (R^2 + z^2)^{3/2}} \int_0^{2\pi} \cos \phi' d\phi' = 0$ $B_y = \frac{\mu_0 I R z}{4\pi (R^2 + z^2)^{3/2}} \int_0^{2\pi} \sin \phi' d\phi' = 0$ $B_z = \frac{\mu_0 I R^2}{4\pi (R^2 + z^2)^{3/2}} \int_0^{2\pi} d\phi' = \frac{\mu_0 I R^2}{2(R^2 + z^2)^{3/2}}$

9.10.2 Ampere's law:

Ampere's law states that the line integral of $\vec{B} \cdot d\vec{s}$ around any closed loop is proportional to the total current passing through any surface that is bounded by the closed loop:

$$\oint \vec{B} \cdot d\vec{s} = \mu_0 I_{\text{enc}}$$

To apply Ampere's law to calculate the magnetic field, we use the following procedure:

- (1) Draw an Amperian loop using symmetry arguments.
- (2) Find the current enclosed by the Amperian loop.
- (3) Calculate the line integral $\oint \vec{B} \cdot d\vec{s}$ around the closed loop.
- (4) Equate $\oint \vec{B} \cdot d\vec{s}$ with $\mu_0 I_{\text{enc}}$ and solve for \vec{B} .

Below we summarize how the methodology can be applied to calculate the magnetic field for an infinite wire, an ideal solenoid and a toroid.

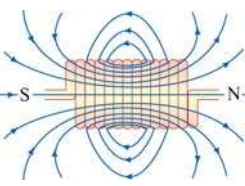
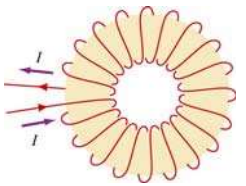
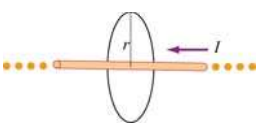
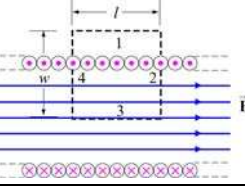
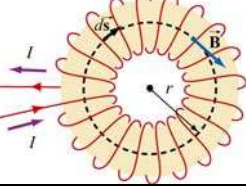
System	Infinite wire	Ideal solenoid	Toroid
Figure			
(1) Draw the Amperian loop			
(2) Find the current enclosed by the Amperian loop	$I_{\text{enc}} = I$	$I_{\text{enc}} = NI$	$I_{\text{enc}} = NI$
(3) Calculate $\oint \vec{B} \cdot d\vec{s}$ along the loop	$\oint \vec{B} \cdot d\vec{s} = B(2\pi r)$	$\oint \vec{B} \cdot d\vec{s} = Bl$	$\oint \vec{B} \cdot d\vec{s} = B(2\pi r)$

(4) Equate $\mu_0 I_{\text{enc}}$ with $\oint \vec{\mathbf{B}} \cdot d\vec{\mathbf{s}}$ to obtain $\vec{\mathbf{B}}$	$B = \frac{\mu_0 I}{2\pi r}$	$B = \frac{\mu_0 NI}{l} = \mu_0 nI$	$B = \frac{\mu_0 NI}{2\pi r}$
----------------------------------------------------------------------------------------------------------------------	------------------------------	-------------------------------------	-------------------------------

9.11 Solved Problems

9.11.1 Magnetic Field of a Straight Wire

Consider a straight wire of length L carrying a current I along the $+x$ -direction, as shown in Figure 9.11.1 (ignore the return path of the current or the source for the current.) What is the magnetic field at an arbitrary point P on the xy -plane?

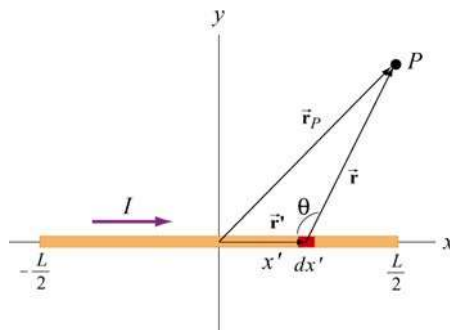

Figure 9.11.1 A finite straight wire carrying a current I .

Solution:

The problem is very similar to Example 9.1. However, now the field point is an arbitrary point in the xy -plane. Once again we solve the problem using the methodology outlined in Section 9.10.

(1) Source point

From Figure 9.10.1, we see that the infinitesimal length dx' described by the position vector $\vec{\mathbf{r}}' = x'\hat{\mathbf{i}}$ constitutes a current source $I d\vec{\mathbf{s}} = (I dx')\hat{\mathbf{i}}$.

(2) Field point

As can be seen from Figure 9.10.1, the position vector for the field point P is $\vec{\mathbf{r}} = x\hat{\mathbf{i}} + y\hat{\mathbf{j}}$.

(3) Relative position vector

The relative position vector from the source to P is $\vec{\mathbf{r}} = \vec{\mathbf{r}}_p - \vec{\mathbf{r}}' = (x-x')\hat{\mathbf{i}} + y\hat{\mathbf{j}}$, with $r = |\vec{\mathbf{r}}_p| = |\vec{\mathbf{r}} - \vec{\mathbf{r}}'| = [(x-x')^2 + y^2]^{1/2}$ being the distance. The corresponding unit vector is

$$\hat{\mathbf{r}} = \frac{\vec{\mathbf{r}}}{r} = \frac{\vec{\mathbf{r}}_p - \vec{\mathbf{r}}'}{|\vec{\mathbf{r}}_p - \vec{\mathbf{r}}'|} = \frac{(x-x')\hat{\mathbf{i}} + y\hat{\mathbf{j}}}{[(x-x')^2 + y^2]^{1/2}}$$

(4) Simplifying the cross product

The cross product $d\vec{\mathbf{s}} \times \vec{\mathbf{r}}$ can be simplified as

$$(dx'\hat{\mathbf{i}}) \times [(x-x')\hat{\mathbf{i}} + y\hat{\mathbf{j}}] = y dx' \hat{\mathbf{k}}$$

where we have used $\hat{\mathbf{i}} \times \hat{\mathbf{i}} = \vec{\mathbf{0}}$ and $\hat{\mathbf{i}} \times \hat{\mathbf{j}} = \hat{\mathbf{k}}$.

(5) Writing down $d\vec{\mathbf{B}}$

Using the Biot-Savart law, the infinitesimal contribution due to $Id\vec{\mathbf{s}}$ is

$$d\vec{\mathbf{B}} = \frac{\mu_0 I}{4\pi} \frac{d\vec{\mathbf{s}} \times \hat{\mathbf{r}}}{r^2} = \frac{\mu_0 I}{4\pi} \frac{d\vec{\mathbf{s}} \times \vec{\mathbf{r}}}{r^3} = \frac{\mu_0 I}{4\pi} \frac{y dx'}{[(x-x')^2 + y^2]^{3/2}} \hat{\mathbf{k}} \quad (9.11.1)$$

Thus, we see that the direction of the magnetic field is in the $+\hat{\mathbf{k}}$ direction.

(6) Carrying out the integration to obtain $\vec{\mathbf{B}}$

The total magnetic field at P can then be obtained by integrating over the entire length of the wire:

$$\begin{aligned} \vec{\mathbf{B}} &= \int_{\text{wire}} d\vec{\mathbf{B}} = \int_{-L/2}^{L/2} \frac{\mu_0 I y dx'}{4\pi [(x-x')^2 + y^2]^{3/2}} \hat{\mathbf{k}} = -\frac{\mu_0 I}{4\pi y} \left. \frac{(x-x')}{\sqrt{(x-x')^2 + y^2}} \right|_{-L/2}^{L/2} \hat{\mathbf{k}} \\ &= -\frac{\mu_0 I}{4\pi y} \left[\frac{(x-L/2)}{\sqrt{(x-L/2)^2 + y^2}} - \frac{(x+L/2)}{\sqrt{(x+L/2)^2 + y^2}} \right] \hat{\mathbf{k}} \end{aligned} \quad (9.11.2)$$

Let's consider the following limits:

(i) $x = 0$

In this case, the field point P is at $(x, y) = (0, y)$ on the y axis. The magnetic field becomes

$$\vec{\mathbf{B}} = -\frac{\mu_0 I}{4\pi y} \left[\frac{-L/2}{\sqrt{(-L/2)^2 + y^2}} - \frac{+L/2}{\sqrt{(+L/2)^2 + y^2}} \right] \hat{\mathbf{k}} = \frac{\mu_0 I}{2\pi y} \frac{L/2}{\sqrt{(L/2)^2 + y^2}} \hat{\mathbf{k}} = \frac{\mu_0 I}{2\pi y} \cos \theta \hat{\mathbf{k}} \quad (9.11.3)$$

in agreement with Eq. (9.1.6).

(ii) Infinite length limit

Consider the limit where $L \gg x, y$. This gives back the expected infinite-length result:

$$\vec{\mathbf{B}} = -\frac{\mu_0 I}{4\pi y} \left[\frac{-L/2}{L/2} - \frac{+L/2}{L/2} \right] \hat{\mathbf{k}} = \frac{\mu_0 I}{2\pi y} \hat{\mathbf{k}} \quad (9.11.4)$$

If we use cylindrical coordinates with the wire pointing along the $+z$ -axis then the magnetic field is given by the expression

$$\vec{\mathbf{B}} = \frac{\mu_0 I}{2\pi r} \hat{\boldsymbol{\phi}} \quad (9.11.5)$$

where $\hat{\boldsymbol{\phi}}$ is the tangential unit vector and the field point P is a distance r away from the wire.

9.11.2 Current-Carrying Arc

Consider the current-carrying loop formed of radial lines and segments of circles whose centers are at point P as shown below. Find the magnetic field $\vec{\mathbf{B}}$ at P .

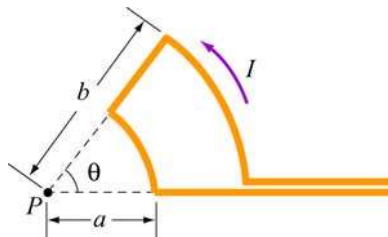

Figure 9.11.2 Current-carrying arc

Solution:

According to the Biot-Savart law, the magnitude of the magnetic field due to a differential current-carrying element $I d\vec{s}$ is given by

$$dB = \frac{\mu_0 I}{4\pi} \frac{|d\vec{s} \times \hat{r}|}{r^2} = \frac{\mu_0 I}{4\pi} \frac{r d\theta'}{r^2} = \frac{\mu_0 I}{4\pi r} d\theta' \quad (9.11.6)$$

For the outer arc, we have

$$B_{\text{outer}} = \frac{\mu_0 I}{4\pi b} \int_0^\theta d\theta' = \frac{\mu_0 I \theta}{4\pi b} \quad (9.11.7)$$

The direction of \vec{B}_{outer} is determined by the cross product $d\vec{s} \times \hat{r}$ which points out of the page. Similarly, for the inner arc, we have

$$B_{\text{inner}} = \frac{\mu_0 I}{4\pi a} \int_0^\theta d\theta' = \frac{\mu_0 I \theta}{4\pi a} \quad (9.11.8)$$

For \vec{B}_{inner} , $d\vec{s} \times \hat{r}$ points into the page. Thus, the total magnitude of magnetic field is

$$\vec{B} = \vec{B}_{\text{inner}} + \vec{B}_{\text{outer}} = \frac{\mu_0 I \theta}{4\pi} \left(\frac{1}{a} - \frac{1}{b} \right) \text{ (into page)} \quad (9.11.9)$$

9.11.3 Rectangular Current Loop

Determine the magnetic field (in terms of I , a and b) at the origin O due to the current loop shown in Figure 9.11.3

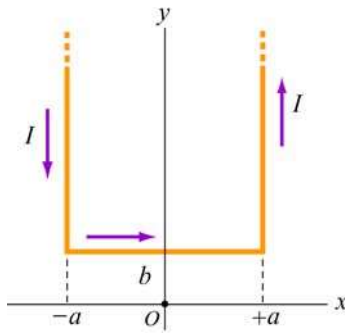

Figure 9.11.3 Rectangular current loop

Solution:

For a finite wire carrying a current I , the contribution to the magnetic field at a point P is given by Eq. (9.1.5):

$$B = \frac{\mu_0 I}{4\pi r} (\cos \theta_1 + \cos \theta_2)$$

where θ_1 and θ_2 are the angles which parameterize the length of the wire.

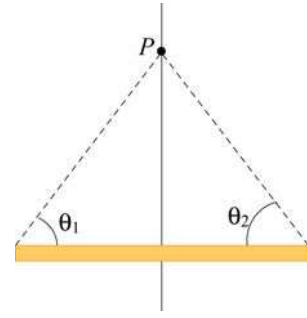

To obtain the magnetic field at O , we make use of the above formula. The contributions can be divided into three parts:

(i) Consider the left segment of the wire which extends from $(x, y) = (-a, +\infty)$ to $(-a, +b)$. The angles which parameterize this segment give $\cos \theta_1 = 1$ ($\theta_1 = 0$) and $\cos \theta_2 = -b/\sqrt{b^2 + a^2}$. Therefore,

$$B_1 = \frac{\mu_0 I}{4\pi a} (\cos \theta_1 + \cos \theta_2) = \frac{\mu_0 I}{4\pi a} \left(1 - \frac{b}{\sqrt{b^2 + a^2}} \right) \quad (9.11.10)$$

The direction of \vec{B}_1 is out of page, or $+\hat{k}$.

(ii) Next, we consider the segment which extends from $(x, y) = (-a, +b)$ to $(+a, +b)$. Again, the (cosine of the) angles are given by

$$\cos \theta_1 = \frac{a}{\sqrt{a^2 + b^2}} \quad (9.11.11)$$

$$\cos \theta_2 = \cos \theta_1 = \frac{a}{\sqrt{a^2 + b^2}} \quad (9.11.12)$$

This leads to

$$B_2 = \frac{\mu_0 I}{4\pi b} \left(\frac{a}{\sqrt{a^2 + b^2}} + \frac{a}{\sqrt{a^2 + b^2}} \right) = \frac{\mu_0 I a}{2\pi b \sqrt{a^2 + b^2}} \quad (9.11.13)$$

The direction of \vec{B}_2 is into the page, or $-\hat{k}$.

(iii) The third segment of the wire runs from $(x, y) = (+a, +b)$ to $(+a, +\infty)$. One may readily show that it gives the same contribution as the first one:

$$B_3 = B_1 \quad (9.11.14)$$

The direction of $\vec{\mathbf{B}}_3$ is again out of page, or $+\hat{\mathbf{k}}$.

The magnetic field is

$$\begin{aligned}\vec{\mathbf{B}} &= \vec{\mathbf{B}}_1 + \vec{\mathbf{B}}_2 + \vec{\mathbf{B}}_3 = 2\vec{\mathbf{B}}_1 + \vec{\mathbf{B}}_2 = \frac{\mu_0 I}{2\pi a} \left(1 - \frac{b}{\sqrt{a^2 + b^2}} \right) \hat{\mathbf{k}} - \frac{\mu_0 I a}{2\pi b \sqrt{a^2 + b^2}} \hat{\mathbf{k}} \\ &= \frac{\mu_0 I}{2\pi a b \sqrt{a^2 + b^2}} \left(b\sqrt{a^2 + b^2} - b^2 - a^2 \right) \hat{\mathbf{k}}\end{aligned}\quad (9.11.15)$$

Note that in the limit $a \rightarrow 0$, the horizontal segment is absent, and the two semi-infinite wires carrying currents in the opposite direction overlap each other and their contributions completely cancel. Thus, the magnetic field vanishes in this limit.

9.11.4 Hairpin-Shaped Current-Carrying Wire

An infinitely long current-carrying wire is bent into a hairpin-like shape shown in Figure 9.11.4. Find the magnetic field at the point P which lies at the center of the half-circle.

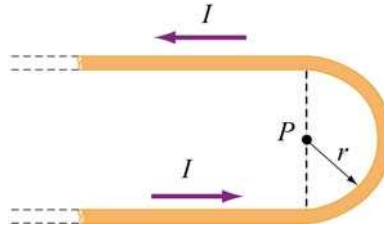

Figure 9.11.4 Hairpin-shaped current-carrying wire

Solution:

Again we break the wire into three parts: two semi-infinite plus a semi-circular segments.

(i) Let P be located at the origin in the xy plane. The first semi-infinite segment then extends from $(x, y) = (-\infty, -r)$ to $(0, -r)$. The two angles which parameterize this segment are characterized by $\cos \theta_1 = 1$ ($\theta_1 = 0$) and $\cos \theta_2 = 0$ ($\theta_2 = \pi/2$). Therefore, its contribution to the magnetic field at P is

$$B_1 = \frac{\mu_0 I}{4\pi r} (\cos \theta_1 + \cos \theta_2) = \frac{\mu_0 I}{4\pi r} (1 + 0) = \frac{\mu_0 I}{4\pi r}\quad (9.11.16)$$

The direction of $\vec{\mathbf{B}}_1$ is out of page, or $+\hat{\mathbf{k}}$.

(ii) For the semi-circular arc of radius r , we make use of the Biot-Savart law:

$$\vec{\mathbf{B}} = \frac{\mu_0 I}{4\pi} \int \frac{d\vec{\mathbf{s}} \times \hat{\mathbf{r}}}{r^2} \quad (9.11.17)$$

and obtain

$$B_2 = \frac{\mu_0 I}{4\pi} \int_0^\pi \frac{rd\theta}{r^2} = \frac{\mu_0 I}{4r} \quad (9.11.18)$$

The direction of $\vec{\mathbf{B}}_2$ is out of page, or $+\hat{\mathbf{k}}$.

(iii) The third segment of the wire runs from $(x, y) = (0, +r)$ to $(-\infty, +r)$. One may readily show that it gives the same contribution as the first one:

$$B_3 = B_1 = \frac{\mu_0 I}{4\pi r} \quad (9.11.19)$$

The direction of $\vec{\mathbf{B}}_3$ is again out of page, or $+\hat{\mathbf{k}}$.

The total magnitude of the magnetic field is

$$\vec{\mathbf{B}} = \vec{\mathbf{B}}_1 + \vec{\mathbf{B}}_2 + \vec{\mathbf{B}}_3 = 2\vec{\mathbf{B}}_1 + \vec{\mathbf{B}}_2 = \frac{\mu_0 I}{2\pi r} \hat{\mathbf{k}} + \frac{\mu_0 I}{4r} \hat{\mathbf{k}} = \frac{\mu_0 I}{4\pi r} (2 + \pi) \hat{\mathbf{k}} \quad (9.11.20)$$

Notice that the contribution from the two semi-infinite wires is equal to that due to an infinite wire:

$$\vec{\mathbf{B}}_1 + \vec{\mathbf{B}}_3 = 2\vec{\mathbf{B}}_1 = \frac{\mu_0 I}{2\pi r} \hat{\mathbf{k}} \quad (9.11.21)$$

9.11.5 Two Infinitely Long Wires

Consider two infinitely long wires carrying currents are in the $-x$ -direction.

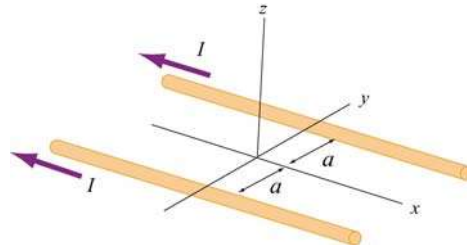

Figure 9.11.5 Two infinitely long wires

- (a) Plot the magnetic field pattern in the yz -plane.
- (b) Find the distance d along the z -axis where the magnetic field is a maximum.

Solutions:

- (a) The magnetic field lines are shown in Figure 9.11.6. Notice that the directions of both currents are into the page.

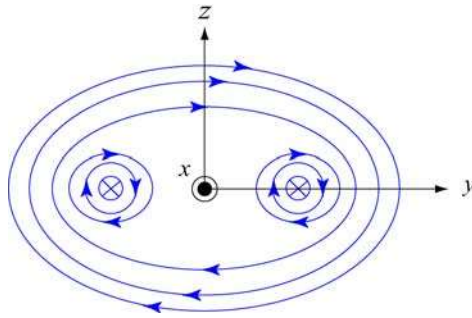

Figure 9.11.6 Magnetic field lines of two wires carrying current in the same direction.

- (b) The magnetic field at $(0, 0, z)$ due to wire 1 on the left is, using Ampere's law:

$$B_1 = \frac{\mu_0 I}{2\pi r} = \frac{\mu_0 I}{2\pi\sqrt{a^2 + z^2}} \quad (9.11.22)$$

Since the current is flowing in the $-x$ -direction, the magnetic field points in the direction of the cross product

$$(-\hat{\mathbf{i}}) \times \hat{\mathbf{r}}_1 = (-\hat{\mathbf{i}}) \times (\cos \theta \hat{\mathbf{j}} + \sin \theta \hat{\mathbf{k}}) = \sin \theta \hat{\mathbf{j}} - \cos \theta \hat{\mathbf{k}} \quad (9.11.23)$$

Thus, we have

$$\vec{\mathbf{B}}_1 = \frac{\mu_0 I}{2\pi\sqrt{a^2 + z^2}} (\sin \theta \hat{\mathbf{j}} - \cos \theta \hat{\mathbf{k}}) \quad (9.11.24)$$

For wire 2 on the right, the magnetic field strength is the same as the left one: $B_1 = B_2$. However, its direction is given by

$$(-\hat{\mathbf{i}}) \times \hat{\mathbf{r}}_2 = (-\hat{\mathbf{i}}) \times (-\cos \theta \hat{\mathbf{j}} + \sin \theta \hat{\mathbf{k}}) = \sin \theta \hat{\mathbf{j}} + \cos \theta \hat{\mathbf{k}} \quad (9.11.25)$$

Adding up the contributions from both wires, the z -components cancel (as required by symmetry), and we arrive at

$$\vec{\mathbf{B}} = \vec{\mathbf{B}}_1 + \vec{\mathbf{B}}_2 = \frac{\mu_0 I \sin \theta}{\pi \sqrt{a^2 + z^2}} \hat{\mathbf{j}} = \frac{\mu_0 I z}{\pi (a^2 + z^2)} \hat{\mathbf{j}} \quad (9.11.26)$$

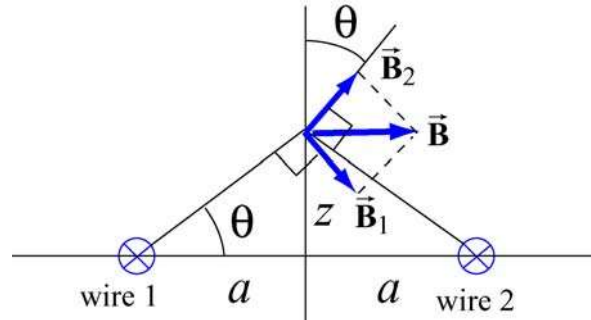

Figure 9.11.7 Superposition of magnetic fields due to two current sources

To locate the maximum of B , we set $dB/dz = 0$ and find

$$\frac{dB}{dz} = \frac{\mu_0 I}{\pi} \left(\frac{1}{a^2 + z^2} - \frac{2z^2}{(a^2 + z^2)^2} \right) = \frac{\mu_0 I}{\pi} \frac{a^2 - z^2}{(a^2 + z^2)^2} = 0 \quad (9.11.27)$$

which gives

$$z = a \quad (9.11.28)$$

Thus, at $z=a$, the magnetic field strength is a maximum, with a magnitude

$$B_{\max} = \frac{\mu_0 I}{2\pi a} \quad (9.11.29)$$

9.11.6 Non-Uniform Current Density

Consider an infinitely long, cylindrical conductor of radius R carrying a current I with a non-uniform current density

$$J = \alpha r \quad (9.11.30)$$

where α is a constant. Find the magnetic field everywhere.

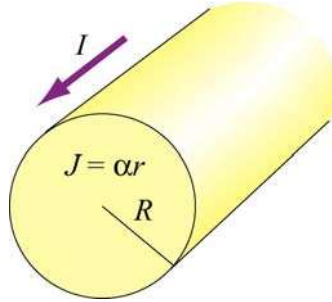

Figure 9.11.8 Non-uniform current density

Solution:

The problem can be solved by using the Ampere's law:

$$\oint \vec{\mathbf{B}} \cdot d\vec{\mathbf{s}} = \mu_0 I_{\text{enc}} \quad (9.11.31)$$

where the enclosed current I_{enc} is given by

$$I_{\text{enc}} = \int \vec{\mathbf{J}} \cdot d\vec{\mathbf{A}} = \int (\alpha r') (2\pi r' dr') \quad (9.11.32)$$

(a) For $r < R$, the enclosed current is

$$I_{\text{enc}} = \int_0^r 2\pi\alpha r'^2 dr' = \frac{2\pi\alpha r^3}{3} \quad (9.11.33)$$

Applying Ampere's law, the magnetic field at P_1 is given by

$$B_1 (2\pi r) = \frac{2\mu_0\pi\alpha r^3}{3} \quad (9.11.34)$$

or

$$\boxed{B_1 = \frac{\alpha\mu_0}{3} r^2} \quad (9.11.35)$$

The direction of the magnetic field $\vec{\mathbf{B}}_1$ is tangential to the Amperian loop which encloses the current.

(b) For $r > R$, the enclosed current is

$$I_{\text{enc}} = \int_0^R 2\pi\alpha r'^2 dr' = \frac{2\pi\alpha R^3}{3} \quad (9.11.36)$$

which yields

$$B_2(2\pi r) = \frac{2\mu_0\pi\alpha R^3}{3} \quad (9.11.37)$$

Thus, the magnetic field at a point P_2 outside the conductor is

$$\boxed{B_2 = \frac{\alpha\mu_0 R^3}{3r}} \quad (9.11.38)$$

A plot of B as a function of r is shown in Figure 9.11.9:

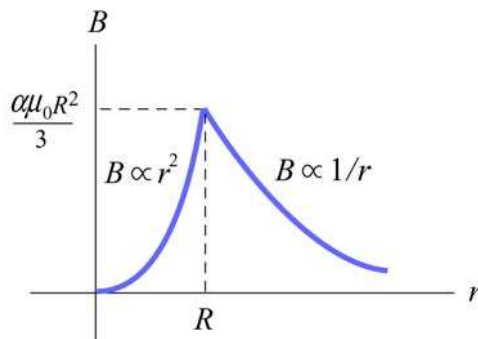

Figure 9.11.9 The magnetic field as a function of distance away from the conductor

9.11.7 Thin Strip of Metal

Consider an infinitely long, thin strip of metal of width w lying in the xy plane. The strip carries a current I along the $+x$ -direction, as shown in Figure 9.11.10. Find the magnetic field at a point P which is in the plane of the strip and at a distance s away from it.

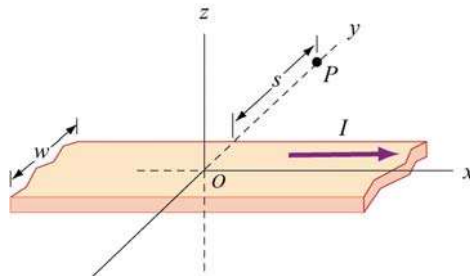

Figure 9.11.10 Thin strip of metal

Solution:

Consider a thin strip of width dr parallel to the direction of the current and at a distance r away from P , as shown in Figure 9.11.11. The amount of current carried by this differential element is

$$dI = I \left(\frac{dr}{w} \right) \quad (9.11.39)$$

Using Ampere's law, we see that the strip's contribution to the magnetic field at P is given by

$$dB(2\pi r) = \mu_0 I_{\text{enc}} = \mu_0 (dI) \quad (9.11.40)$$

or

$$dB = \frac{\mu_0 dI}{2\pi r} = \frac{\mu_0}{2\pi r} \left(\frac{I dr}{w} \right) \quad (9.11.41)$$

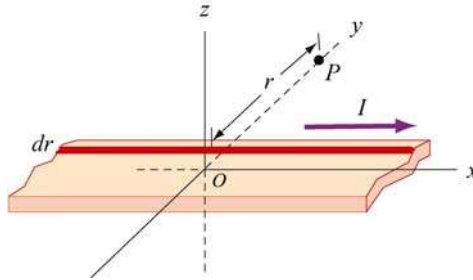

Figure 9.11.11 A thin strip with thickness dr carrying a steady current I .

Integrating this expression, we obtain

$$B = \int_s^{s+w} \frac{\mu_0 I}{2\pi w} \left(\frac{dr}{r} \right) = \frac{\mu_0 I}{2\pi w} \ln \left(\frac{s+w}{s} \right) \quad (9.11.42)$$

Using the right-hand rule, the direction of the magnetic field can be shown to point in the $+z$ -direction, or

$$\vec{B} = \frac{\mu_0 I}{2\pi w} \ln \left(1 + \frac{w}{s} \right) \hat{\mathbf{k}} \quad (9.11.43)$$

Notice that in the limit of vanishing width, $w \ll s$, $\ln(1 + w/s) \approx w/s$, and the above expression becomes

$$\vec{B} = \frac{\mu_0 I}{2\pi s} \hat{\mathbf{k}} \quad (9.11.44)$$

which is the magnetic field due to an infinitely long thin straight wire.

9.11.8 Two Semi-Infinite Wires

A wire carrying current I runs down the y axis to the origin, thence out to infinity along the positive x axis. Show that the magnetic field in the quadrant with $x, y > 0$ of the xy plane is given by

$$B_z = \frac{\mu_0 I}{4\pi} \left(\frac{1}{x} + \frac{1}{y} + \frac{x}{y\sqrt{x^2 + y^2}} + \frac{y}{x\sqrt{x^2 + y^2}} \right) \quad (9.11.45)$$

Solution:

Let $P(x, y)$ be a point in the first quadrant at a distance r_1 from a point $(0, y')$ on the y -axis and distance r_2 from $(x', 0)$ on the x -axis.

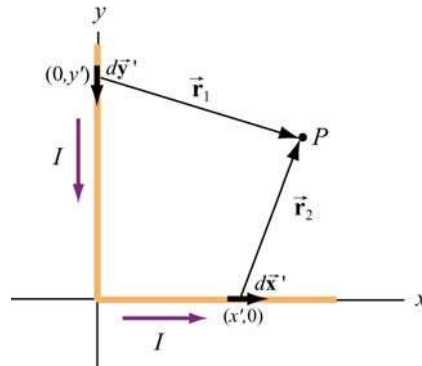

Figure 9.11.12 Two semi-infinite wires

Using the Biot-Savart law, the magnetic field at P is given by

$$\vec{B} = \int d\vec{B} = \frac{\mu_0 I}{4\pi} \int \frac{d\vec{s} \times \hat{r}}{r^2} = \frac{\mu_0 I}{4\pi} \int_{\text{wire } y} \frac{d\vec{s}_1 \times \hat{r}_1}{r_1^2} + \frac{\mu_0 I}{4\pi} \int_{\text{wire } x} \frac{d\vec{s}_2 \times \hat{r}_2}{r_2^2} \quad (9.11.46)$$

Let's analyze each segment separately.

(i) Along the y axis, consider a differential element $d\vec{s}_1 = -dy' \hat{j}$ which is located at a distance $\vec{r}_1 = x\hat{i} + (y - y')\hat{j}$ from P . This yields

$$d\vec{s}_1 \times \vec{r}_1 = (-dy' \hat{j}) \times [x\hat{i} + (y - y')\hat{j}] = x dy' \hat{k} \quad (9.11.47)$$

(ii) Similarly, along the x -axis, we have $d\vec{s}_2 = dx'\hat{\mathbf{i}}$ and $\vec{r}_2 = (x-x')\hat{\mathbf{i}} + y\hat{\mathbf{j}}$ which gives

$$d\vec{s}_2 \times \vec{r}_2 = y dx' \hat{\mathbf{k}} \quad (9.11.48)$$

Thus, we see that the magnetic field at P points in the $+z$ -direction. Using the above results and $r_1 = \sqrt{x^2 + (y-y')^2}$ and $r_2 = \sqrt{(x-x')^2 + y^2}$, we obtain

$$B_z = \frac{\mu_0 I}{4\pi} \int_0^\infty \frac{x dy'}{[x^2 + (y-y')^2]^{3/2}} + \frac{\mu_0 I}{4\pi} \int_0^\infty \frac{y dx'}{[y^2 + (x-x')^2]^{3/2}} \quad (9.11.49)$$

The integrals can be readily evaluated using

$$\int_0^\infty \frac{b ds}{[b^2 + (a-s)^2]^{3/2}} = \frac{1}{b} + \frac{a}{b\sqrt{a^2 + b^2}} \quad (9.11.50)$$

The final expression for the magnetic field is given by

$$\vec{\mathbf{B}} = \frac{\mu_0 I}{4\pi} \left[\frac{1}{x} + \frac{y}{x\sqrt{x^2 + y^2}} + \frac{1}{y} + \frac{x}{y\sqrt{x^2 + y^2}} \right] \hat{\mathbf{k}} \quad (9.11.51)$$

We may show that the result is consistent with Eq. (9.1.5)

9.12 Conceptual Questions

1. Compare and contrast Biot-Savart law in magnetostatics with Coulomb's law in electrostatics.
2. If a current is passed through a spring, does the spring stretch or compress? Explain.
3. How is the path of the integration of $\oint \vec{\mathbf{B}} \cdot d\vec{\mathbf{s}}$ chosen when applying Ampere's law?
4. Two concentric, coplanar circular loops of different diameters carry steady currents in the same direction. Do the loops attract or repel each other? Explain.
5. Suppose three infinitely long parallel wires are arranged in such a way that when looking at the cross section, they are at the corners of an equilateral triangle. Can currents be arranged (combination of flowing in or out of the page) so that all three wires (a) attract, and (b) repel each other? Explain.

9.13 Additional Problems

9.13.1 Application of Ampere's Law

The simplest possible application of Ampere's law allows us to calculate the magnetic field in the vicinity of a single infinitely long wire. Adding more wires with differing currents will check your understanding of Ampere's law.

(a) Calculate with Ampere's law the magnetic field, $|\vec{B}| = B(r)$, as a function of distance r from the wire, in the vicinity of an infinitely long straight wire that carries current I . Show with a sketch the integration path you choose and state explicitly how you use symmetry. What is the field at a distance of 10 mm from the wire if the current is 10 A?

(b) Eight parallel wires cut the page perpendicularly at the points shown. A wire labeled with the integer k ($k = 1, 2, \dots, 8$) bears the current $2k$ times I_0 (i.e., $I_k = 2k I_0$). For those with $k = 1$ to 4, the current flows up out of the page; for the rest, the current flows down into the page. Evaluate $\oint \vec{B} \cdot d\vec{s}$ along the closed path (see figure) in the direction indicated by the arrowhead. (Watch your signs!)

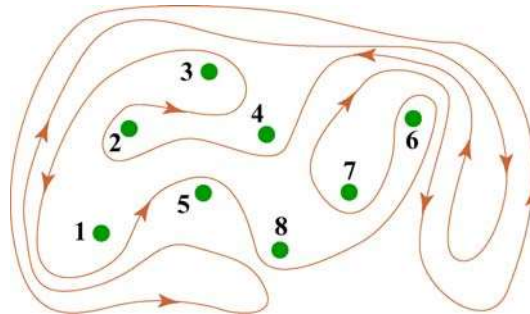

Figure 9.13.1 Amperian loop

(c) Can you use a single application of Ampere's Law to find the field at a point in the vicinity of the 8 wires? Why? How would you proceed to find the field at an arbitrary point P ?

9.13.2 Magnetic Field of a Current Distribution from Ampere's Law

Consider the cylindrical conductor with a hollow center and copper walls of thickness $b - a$ as shown in Figure 9.13.2. The radii of the inner and outer walls are a and b respectively, and the current I is uniformly spread over the cross section of the copper.

(a) Calculate the magnitude of the magnetic field in the region outside the conductor, $r > b$. (Hint: consider the entire conductor to be a single thin wire, construct an Amperian loop, and apply Ampere's Law.) What is the direction of \vec{B} ?

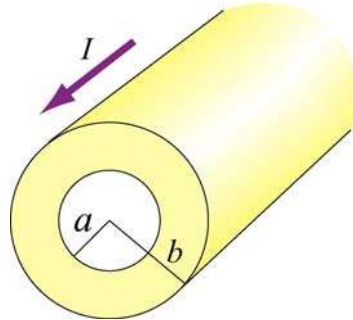

Figure 9.13.2 Hollow cylinder carrying a steady current I .

(b) Calculate the magnetic field inside the inner radius, $r < a$. What is the direction of \vec{B} ?

(c) Calculate the magnetic field within the inner conductor, $a < r < b$. What is the direction of \vec{B} ?

(d) Plot the behavior of the magnitude of the magnetic field $B(r)$ from $r = 0$ to $r = 4b$. Is $B(r)$ continuous at $r = a$ and $r = b$? What about its slope?

(e) Now suppose that a very thin wire running down the center of the conductor carries the same current I in the opposite direction. Can you plot, roughly, the variation of $B(r)$ without another detailed calculation? (Hint: remember that the vectors $d\vec{B}$ from different current elements can be added to obtain the total vector magnetic field.)

9.13.3 Cylinder with a Hole

A long copper rod of radius a has an off-center cylindrical hole through its entire length, as shown in Figure 9.13.3. The conductor carries a current I which is directed out of the page and is uniformly distributed throughout the cross section. Find the magnitude and direction of the magnetic field at the point P .

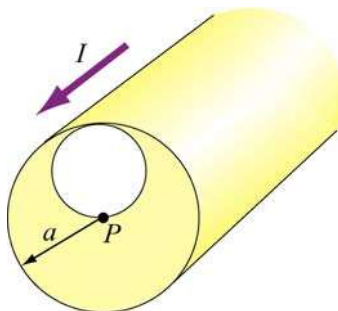

Figure 9.13.3 A cylindrical conductor with a hole.

9.13.4 The Magnetic Field Through a Solenoid

A solenoid has 200 closely spaced turns so that, for most of its length, it may be considered to be an ideal solenoid. It has a length of 0.25 m, a diameter of 0.1 m, and carries a current of 0.30 A.

- (a) Sketch the solenoid, showing clearly the rotation direction of the windings, the current direction, and the magnetic field lines (inside and outside) with arrows to show their direction. What is the dominant direction of the magnetic field inside the solenoid?
- (b) Find the magnitude of the magnetic field inside the solenoid by constructing an Amperian loop and applying Ampere's law.
- (c) Does the magnetic field have a component in the direction of the wire in the loops making up the solenoid? If so, calculate its magnitude both inside and outside the solenoid, at radii 30 mm and 60 mm respectively, and show the directions on your sketch.

9.13.5 Rotating Disk

A circular disk of radius R with uniform charge density σ rotates with an angular speed ω . Show that the magnetic field at the center of the disk is

$$B = \frac{1}{2} \mu_0 \sigma \omega R$$

Hint: Consider a circular ring of radius r and thickness dr . Show that the current in this element is $dI = (\omega / 2\pi) dq = \omega \sigma r dr$.

9.13.6 Four Long Conducting Wires

Four infinitely long parallel wires carrying equal current I are arranged in such a way that when looking at the cross section, they are at the corners of a square, as shown in Figure 9.13.5. Currents in A and D point out of the page, and into the page at B and C . What is the magnetic field at the center of the square?

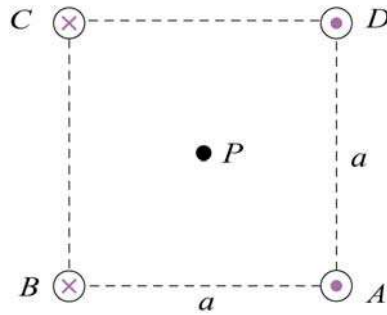

Figure 9.13.5 Four parallel conducting wires

9.13.7 Magnetic Force on a Current Loop

A rectangular loop of length l and width w carries a steady current I_1 . The loop is then placed near a finitely long wire carrying a current I_2 , as shown in Figure 9.13.6. What is the magnetic force experienced by the loop due to the magnetic field of the wire?

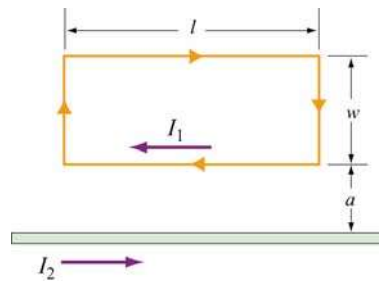

Figure 9.13.6 Magnetic force on a current loop.

9.13.8 Magnetic Moment of an Orbital Electron

We want to estimate the magnetic dipole moment associated with the motion of an electron as it orbits a proton. We use a “semi-classical” model to do this. Assume that the electron has speed v and orbits a proton (assumed to be very massive) located at the origin. The electron is moving in a right-handed sense with respect to the z -axis in a circle of radius $r = 0.53 \text{ \AA}$, as shown in Figure 9.13.7. Note that $1 \text{ \AA} = 10^{-10} \text{ m}$.

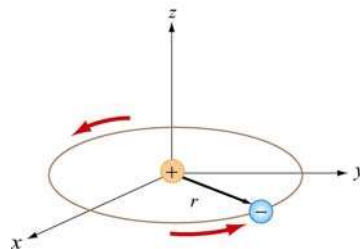

Figure 9.13.7

(a) The inward force $m_e v^2 / r$ required to make the electron move in this circle is provided by the Coulomb attractive force between the electron and proton (m_e is the mass of the electron). Using this fact, and the value of r we give above, find the speed of the electron in our “semi-classical” model. [Ans: 2.18×10^6 m/s.]

(b) Given this speed, what is the orbital period T of the electron? [Ans: 1.52×10^{-16} s.]

(c) What current is associated with this motion? Think of the electron as stretched out uniformly around the circumference of the circle. In a time T , the total amount of charge q that passes an observer at a point on the circle is just e [Ans: 1.05 mA. Big!]

(d) What is the magnetic dipole moment associated with this orbital motion? Give the magnitude and direction. The magnitude of this dipole moment is one *Bohr magneton*, μ_B . [Ans: 9.27×10^{-24} A·m² along the $-z$ axis.]

(e) One of the reasons this model is “semi-classical” is because classically there is no reason for the radius of the orbit above to assume the specific value we have given. The value of r is determined from quantum mechanical considerations, to wit that the orbital angular momentum of the electron can only assume integral multiples of $h/2\pi$, where $h = 6.63 \times 10^{-34}$ J/s is the Planck constant. What is the orbital angular momentum of the electron here, in units of $h/2\pi$?

9.13.9 Ferromagnetism and Permanent Magnets

A disk of iron has a height $h = 1.00$ mm and a radius $r = 1.00$ cm. The magnetic dipole moment of an atom of iron is $\mu = 1.8 \times 10^{-23}$ A·m². The molar mass of iron is 55.85 g, and its density is 7.9 g/cm³. Assume that all the iron atoms in the disk have their dipole moments aligned with the axis of the disk.

(a) What is the number density of the iron atoms? How many atoms are in this disk? [Ans: 8.5×10^{28} atoms/m³; 2.7×10^{22} atoms.]

(b) What is the magnetization \vec{M} in this disk? [Ans: 1.53×10^6 A/m, parallel to axis.]

(c) What is the magnetic dipole moment of the disk? [Ans: 0.48 A·m².]

(d) If we were to wrap one loop of wire around a circle of the same radius r , how much current would the wire have to carry to get the dipole moment in (c)? This is the “equivalent” surface current due to the atomic currents in the interior of the magnet. [Ans: 1525 A.]

9.13.10 Charge in a Magnetic Field

A coil of radius R with its symmetric axis along the $+x$ -direction carries a steady current I . A positive charge q moves with a velocity $\vec{v} = v\hat{j}$ when it crosses the axis at a distance x from the center of the coil, as shown in Figure 9.13.8.

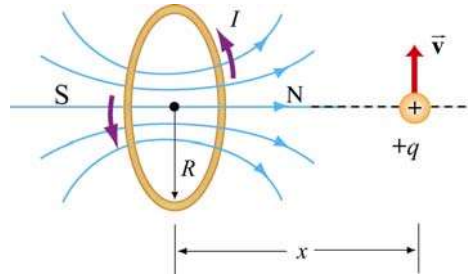

Figure 9.13.8

Describe the subsequent motion of the charge. What is the instantaneous radius of curvature?

9.13.11 Permanent Magnets

A magnet in the shape of a cylindrical rod has a length of 4.8 cm and a diameter of 1.1 cm. It has a uniform magnetization M of 5300 A/m, directed parallel to its axis.

- Calculate the magnetic dipole moment of this magnet.
- What is the axial field a distance of 1 meter from the center of this magnet, along its axis? [Ans: (a) $2.42 \times 10^{-2} \text{ A} \cdot \text{m}^2$, (b) $4.8 \times 10^{-9} \text{ T}$, or $4.8 \times 10^{-5} \text{ gauss}$.]

9.13.12 Magnetic Field of a Solenoid

- A 3000-turn solenoid has a length of 60 cm and a diameter of 8 cm. If this solenoid carries a current of 5.0 A, find the magnitude of the magnetic field inside the solenoid by constructing an Amperian loop and applying Ampere's Law. How does this compare to the magnetic field of the earth (0.5 gauss). [Ans: 0.0314 T, or 314 gauss, or about 600 times the magnetic field of the earth].

We make a magnetic field in the following way: We have a long cylindrical shell of non-conducting material which carries a surface charge fixed in place (glued down) of $\sigma \text{ C/m}^2$, as shown in Figure 9.13.9 The cylinder is suspended in a manner such that it is free to revolve about its axis, without friction. Initially it is at rest. We come along and spin it up until the speed of the surface of the cylinder is v_0 .

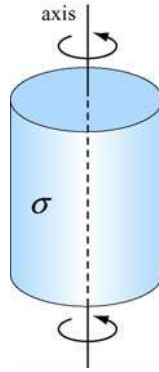

Figure 9.13.9

- (b) What is the surface current K on the walls of the cylinder, in A/m? [Ans: $K = \sigma v_0$.]
- (c) What is magnetic field inside the cylinder? [Ans. $B = \mu_0 K = \mu_0 \sigma v_0$, oriented along axis right-handed with respect to spin.]
- (d) What is the magnetic field outside of the cylinder? Assume that the cylinder is infinitely long. [Ans: 0].

9.13.13 Effect of Paramagnetism

A solenoid with 16 turns/cm carries a current of 1.3 A.

- (a) By how much does the magnetic field inside the solenoid increase when a close-fitting chromium rod is inserted? [Note: Chromium is a paramagnetic material with magnetic susceptibility $\chi = 2.7 \times 10^{-4}$.]
- (b) Find the magnitude of the magnetization \vec{M} of the rod. [Ans: (a) $0.86 \mu\text{T}$; (b) 0.68 A/m .]

Chapter 10

Faraday's Law of Induction

10.1 Faraday's Law of Induction.....	1
10.1.1 Magnetic Flux.....	2
10.1.2 Lenz's Law.....	4
10.2 Motional EMF.....	6
10.3 Induced Electric Field.....	9
10.4 Generators.....	11
10.5 Eddy Currents	12
10.6 Summary.....	14
10.7 Appendix: Induced Emf and Reference Frames	14
10.8 Problem-Solving Tips: Faraday's Law and Lenz's Law	15
10.9 Solved Problems	16
10.9.1 Rectangular Loop Near a Wire	16
10.9.2 Loop Changing Area.....	18
10.9.3 Sliding Rod	19
10.9.4 Moving Bar	20
10.9.5 Time-Varying Magnetic Field	21
10.9.6 Moving Loop	22
10.10 Conceptual Questions	23
10.11 Additional Problems	24
10.11.1 Sliding Bar	24
10.11.2 Sliding Bar on Wedges	25
10.11.3 RC Circuit in a Magnetic Field.....	26
10.11.4 Sliding Bar	26
10.11.5 Rotating Bar.....	27
10.11.6 Rectangular Loop Moving Through Magnetic Field.....	27
10.11.7 Magnet Moving Through a Coil of Wire.....	28
10.11.8 Alternating-Current Generator.....	28
10.11.9 EMF Due to a Time-Varying Magnetic Field.....	29
10.11.10 Square Loop Moving Through Magnetic Field	30
10.11.11 Falling Loop.....	30

Faraday's Law of Induction

10.1 Faraday's Law of Induction

The electric fields and magnetic fields considered up to now have been produced by stationary charges and moving charges (currents), respectively. Imposing an electric field on a conductor gives rise to a current which in turn generates a magnetic field. One could then inquire whether or not an electric field could be produced by a magnetic field. In 1831, Michael Faraday discovered that, by varying magnetic field with time, an electric field could be generated. The phenomenon is known as electromagnetic induction. Figure 10.1.1 illustrates one of Faraday's experiments.

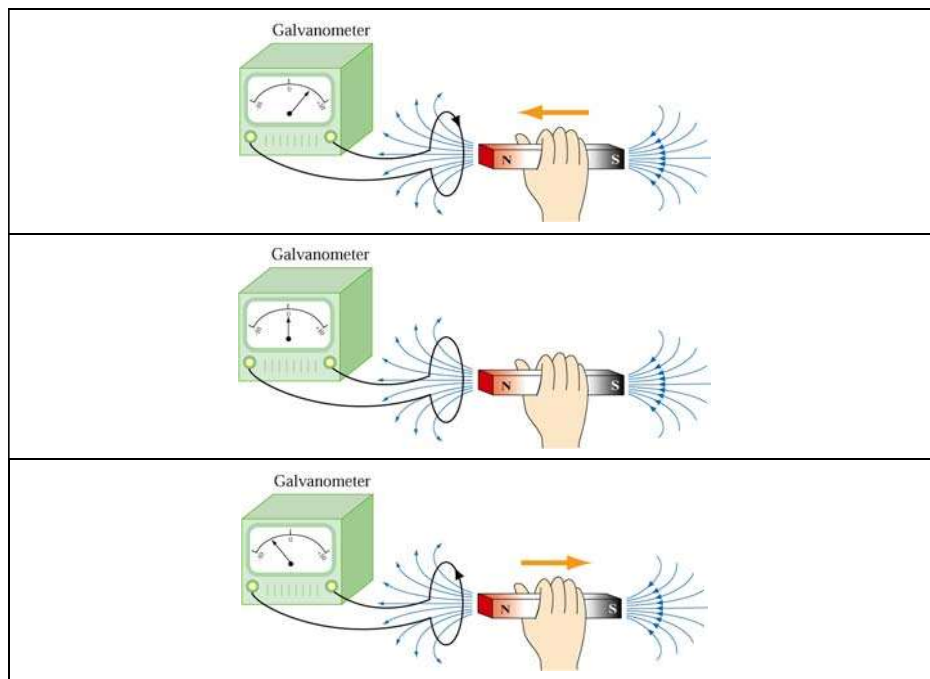

Figure 10.1.1 Electromagnetic induction

Faraday showed that no current is registered in the galvanometer when bar magnet is stationary with respect to the loop. However, a current is induced in the loop when a relative motion exists between the bar magnet and the loop. In particular, the galvanometer deflects in one direction as the magnet approaches the loop, and the opposite direction as it moves away.

Faraday's experiment demonstrates that an electric current is induced in the loop by changing the magnetic field. The coil behaves as if it were connected to an emf source. Experimentally it is found that the induced emf depends on the rate of change of magnetic flux through the coil.

10.1.1 Magnetic Flux

Consider a uniform magnetic field passing through a surface S , as shown in Figure 10.1.2 below:

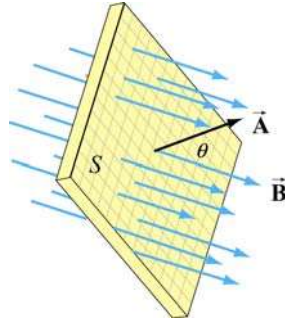

Figure 10.1.2 Magnetic flux through a surface

Let the area vector be $\vec{A} = A\hat{n}$, where A is the area of the surface and \hat{n} its unit normal. The magnetic flux through the surface is given by

$$\Phi_B = \vec{B} \cdot \vec{A} = BA \cos \theta \quad (10.1.1)$$

where θ is the angle between \vec{B} and \hat{n} . If the field is non-uniform, Φ_B then becomes

$$\Phi_B = \iint_S \vec{B} \cdot d\vec{A} \quad (10.1.2)$$

The SI unit of magnetic flux is the weber (Wb):

$$1 \text{ Wb} = 1 \text{ T} \cdot \text{m}^2$$

Faraday's law of induction may be stated as follows:

The induced emf \mathcal{E} in a coil is proportional to the negative of the rate of change of magnetic flux:

$$\mathcal{E} = -\frac{d\Phi_B}{dt} \quad (10.1.3)$$

For a coil that consists of N loops, the total induced emf would be N times as large:

$$\mathcal{E} = -N \frac{d\Phi_B}{dt} \quad (10.1.4)$$

Combining Eqs. (10.1.3) and (10.1.1), we obtain, for a spatially uniform field \vec{B} ,

$$\varepsilon = -\frac{d}{dt}(BA\cos\theta) = -\left(\frac{dB}{dt}\right)A\cos\theta - B\left(\frac{dA}{dt}\right)\cos\theta + BA\sin\theta\left(\frac{d\theta}{dt}\right) \quad (10.1.5)$$

Thus, we see that an emf may be induced in the following ways:

(i) by varying the magnitude of \vec{B} with time (illustrated in Figure 10.1.3.)



Figure 10.1.3 Inducing emf by varying the magnetic field strength

(ii) by varying the magnitude of \vec{A} , i.e., the area enclosed by the loop with time (illustrated in Figure 10.1.4.)

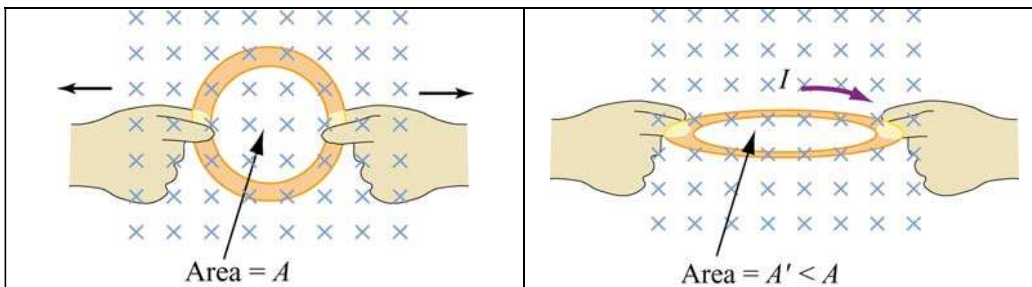

Figure 10.1.4 Inducing emf by changing the area of the loop

(iii) varying the angle between \vec{B} and the area vector \vec{A} with time (illustrated in Figure 10.1.5.)

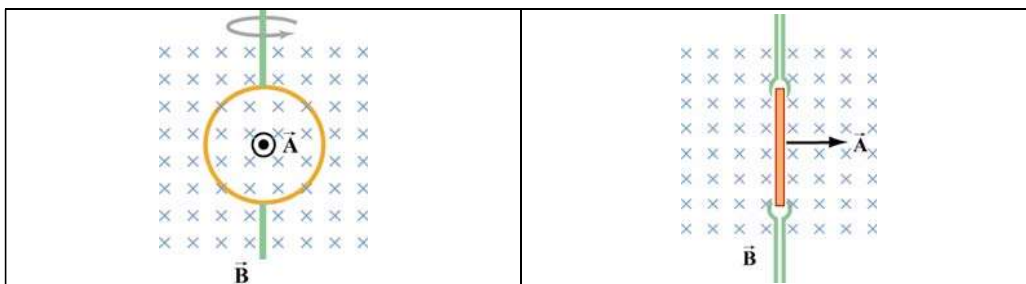

Figure 10.1.5 Inducing emf by varying the angle between \vec{B} and \vec{A} .

10.1.2 Lenz's Law

The direction of the induced current is determined by Lenz's law:

The induced current produces magnetic fields which tend to oppose the change in magnetic flux that induces such currents.

To illustrate how Lenz's law works, let's consider a conducting loop placed in a magnetic field. We follow the procedure below:

1. Define a positive direction for the area vector \vec{A} .
2. Assuming that \vec{B} is uniform, take the dot product of \vec{B} and \vec{A} . This allows for the determination of the sign of the magnetic flux Φ_B .
3. Obtain the rate of flux change $d\Phi_B / dt$ by differentiation. There are three possibilities:

$$\frac{d\Phi_B}{dt}: \begin{cases} > 0 \Rightarrow \text{induced emf } \varepsilon < 0 \\ < 0 \Rightarrow \text{induced emf } \varepsilon > 0 \\ = 0 \Rightarrow \text{induced emf } \varepsilon = 0 \end{cases}$$

4. Determine the direction of the induced current using the right-hand rule. With your thumb pointing in the direction of \vec{A} , curl the fingers around the closed loop. The induced current flows in the same direction as the way your fingers curl if $\varepsilon > 0$, and the opposite direction if $\varepsilon < 0$, as shown in Figure 10.1.6.

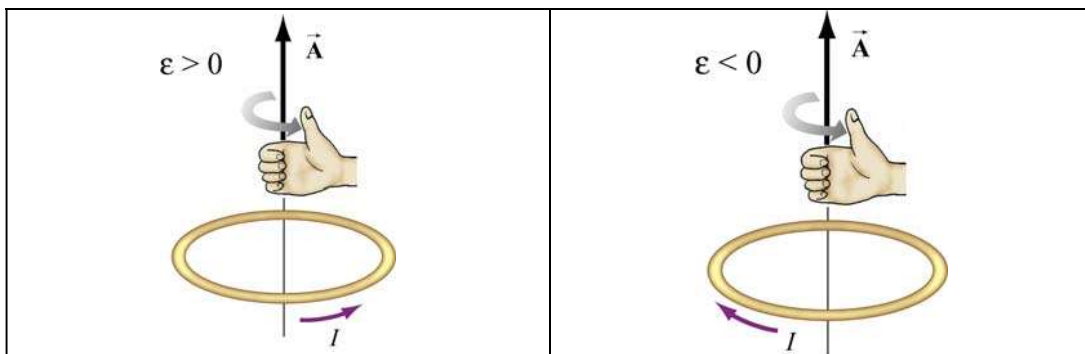

Figure 10.1.6 Determination of the direction of induced current by the right-hand rule

In Figure 10.1.7 we illustrate the four possible scenarios of time-varying magnetic flux and show how Lenz's law is used to determine the direction of the induced current I .

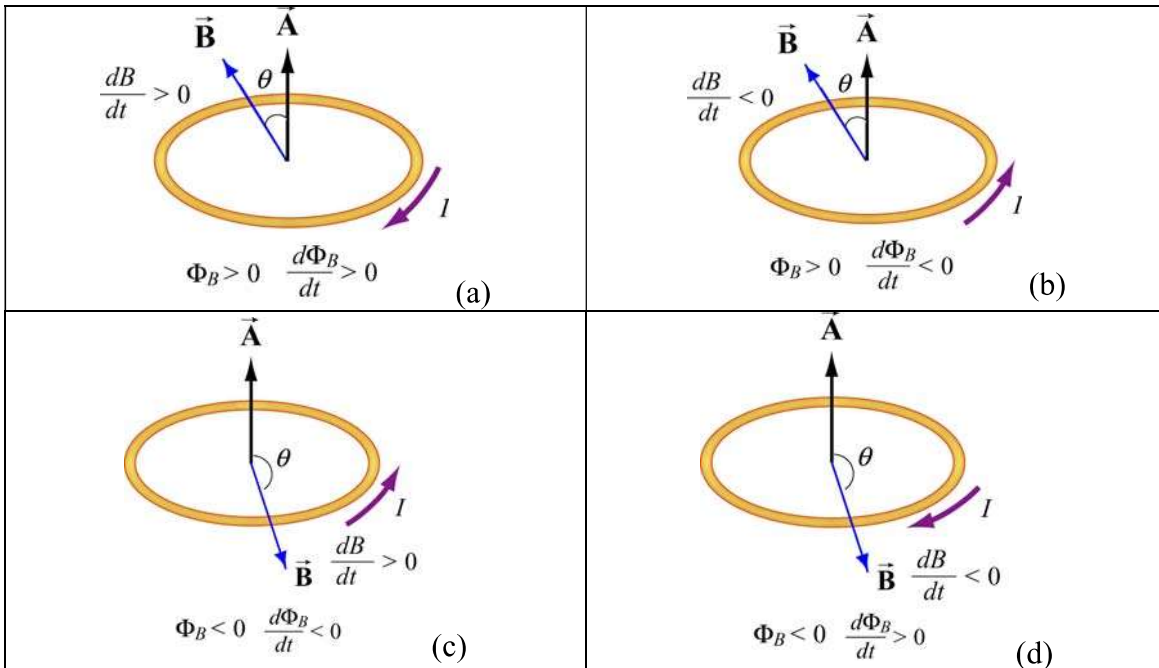

Figure 10.1.7 Direction of the induced current using Lenz's law

The above situations can be summarized with the following sign convention:

Φ_B	$d\Phi_B / dt$	ε	I
+	+	-	-
	-	+	+
-	+	-	-
	-	+	+

The positive and negative signs of I correspond to a counterclockwise and clockwise currents, respectively.

As an example to illustrate how Lenz's law may be applied, consider the situation where a bar magnet is moving toward a conducting loop with its north pole down, as shown in Figure 10.1.8(a). With the magnetic field pointing downward and the area vector \vec{A} pointing upward, the magnetic flux is negative, *i.e.*, $\Phi_B = -BA < 0$, where A is the area of the loop. As the magnet moves closer to the loop, the magnetic field at a point on the loop increases ($dB/dt > 0$), producing more flux through the plane of the loop. Therefore, $d\Phi_B/dt = -A(dB/dt) < 0$, implying a positive induced emf, $\varepsilon > 0$, and the induced current flows in the counterclockwise direction. The current then sets up an induced magnetic field and produces a *positive* flux to counteract the change. The situation described here corresponds to that illustrated in Figure 10.1.7(c).

Alternatively, the direction of the induced current can also be determined from the point of view of magnetic force. Lenz's law states that the induced emf must be in the direction that opposes the change. Therefore, as the bar magnet approaches the loop, it experiences

a repulsive force due to the induced emf. Since like poles repel, the loop must behave as if it were a bar magnet with its north pole pointing up. Using the right-hand rule, the direction of the induced current is counterclockwise, as view from above. Figure 10.1.8(b) illustrates how this alternative approach is used.

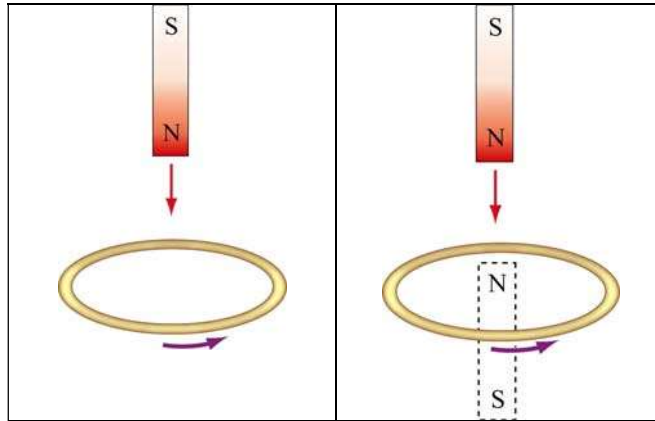

Figure 10.1.8 (a) A bar magnet moving toward a current loop. (b) Determination of the direction of induced current by considering the magnetic force between the bar magnet and the loop

10.2 Motional EMF

Consider a conducting bar of length l moving through a uniform magnetic field which points into the page, as shown in Figure 10.2.1. Particles with charge $q > 0$ inside experience a magnetic force $\vec{F}_B = q\vec{v} \times \vec{B}$ which tends to push them upward, leaving negative charges on the lower end.

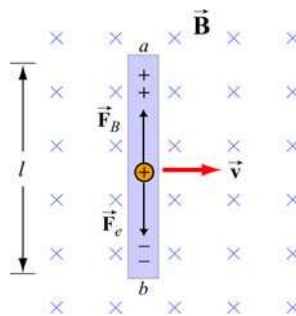

Figure 10.2.1 A conducting bar moving through a uniform magnetic field

The separation of charge gives rise to an electric field \vec{E} inside the bar, which in turn produces a downward electric force $\vec{F}_e = q\vec{E}$. At equilibrium where the two forces cancel,

we have $qvB = qE$, or $E = vB$. Between the two ends of the conductor, there exists a potential difference given by

$$V_{ab} = V_a - V_b = \varepsilon = El = Blv \quad (10.2.1)$$

Since ε arises from the motion of the conductor, this potential difference is called the motional emf. In general, motional emf around a closed conducting loop can be written as

$$\varepsilon = \oint (\vec{v} \times \vec{B}) \cdot d\vec{s} \quad (10.2.2)$$

where $d\vec{s}$ is a differential length element.

Now suppose the conducting bar moves through a region of uniform magnetic field $\vec{B} = -B\hat{k}$ (pointing into the page) by sliding along two frictionless conducting rails that are at a distance l apart and connected together by a resistor with resistance R , as shown in Figure 10.2.2.

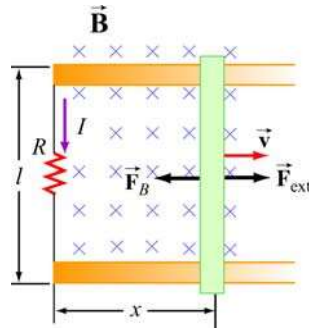

Figure 10.2.2 A conducting bar sliding along two conducting rails

Let an external force \vec{F}_{ext} be applied so that the conductor moves to the right with a constant velocity $\vec{v} = v\hat{i}$. The magnetic flux through the closed loop formed by the bar and the rails is given by

$$\Phi_B = BA = Blx \quad (10.2.3)$$

Thus, according to Faraday's law, the induced emf is

$$\varepsilon = -\frac{d\Phi_B}{dt} = -\frac{d}{dt}(Blx) = -Bl\frac{dx}{dt} = -Blv \quad (10.2.4)$$

where $dx/dt = v$ is simply the speed of the bar. The corresponding induced current is

$$I = \frac{|\varepsilon|}{R} = \frac{Blv}{R} \quad (10.2.5)$$

and its direction is counterclockwise, according to Lenz's law. The equivalent circuit diagram is shown in Figure 10.2.3:

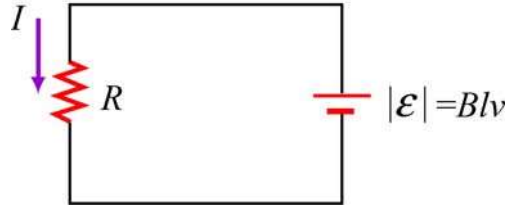

Figure 10.2.3 Equivalent circuit diagram for the moving bar

The magnetic force experienced by the bar as it moves to the right is

$$\vec{F}_B = I(l \hat{j}) \times (-B \hat{k}) = -IlB \hat{i} = -\left(\frac{B^2 l^2 v}{R}\right) \hat{i} \quad (10.2.6)$$

which is in the opposite direction of \vec{v} . For the bar to move at a constant velocity, the net force acting on it must be zero. This means that the external agent must supply a force

$$\vec{F}_{\text{ext}} = -\vec{F}_B = +\left(\frac{B^2 l^2 v}{R}\right) \hat{i} \quad (10.2.7)$$

The power delivered by \vec{F}_{ext} is equal to the power dissipated in the resistor:

$$P = \vec{F}_{\text{ext}} \cdot \vec{v} = F_{\text{ext}} v = \left(\frac{B^2 l^2 v}{R}\right) v = \frac{(Blv)^2}{R} = \frac{\mathcal{E}^2}{R} = I^2 R \quad (10.2.8)$$

as required by energy conservation.

From the analysis above, in order for the bar to move at a constant speed, an external agent must constantly supply a force \vec{F}_{ext} . What happens if at $t = 0$, the speed of the rod is v_0 , and the external agent stops pushing? In this case, the bar will slow down because of the magnetic force directed to the left. From Newton's second law, we have

$$F_B = -\frac{B^2 l^2 v}{R} = ma = m \frac{dv}{dt} \quad (10.2.9)$$

or

$$\frac{dv}{v} = -\frac{B^2 l^2}{mR} dt = -\frac{dt}{\tau} \quad (10.2.10)$$

where $\tau = mR / B^2 l^2$. Upon integration, we obtain

$$v(t) = v_0 e^{-t/\tau} \quad (10.2.11)$$

Thus, we see that the speed decreases exponentially in the absence of an external agent doing work. In principle, the bar never stops moving. However, one may verify that the total distance traveled is finite.

10.3 Induced Electric Field

In Chapter 3, we have seen that the electric potential difference between two points A and B in an electric field \vec{E} can be written as

$$\Delta V = V_B - V_A = -\int_A^B \vec{E} \cdot d\vec{s} \quad (10.3.1)$$

When the electric field is conservative, as is the case of electrostatics, the line integral of $\vec{E} \cdot d\vec{s}$ is path-independent, which implies $\oint \vec{E} \cdot d\vec{s} = 0$.

Faraday's law shows that as magnetic flux changes with time, an induced current begins to flow. What causes the charges to move? It is the induced emf which is the work done per unit charge. However, since magnetic field can do not work, as we have shown in Chapter 8, the work done on the mobile charges must be electric, and the electric field in this situation cannot be conservative because the line integral of a conservative field must vanish. Therefore, we conclude that there is a non-conservative electric field \vec{E}_{nc} associated with an induced emf:

$$\varepsilon = \oint \vec{E}_{nc} \cdot d\vec{s} \quad (10.3.2)$$

Combining with Faraday's law then yields

$$\boxed{\oint \vec{E}_{nc} \cdot d\vec{s} = -\frac{d\Phi_B}{dt}} \quad (10.3.3)$$

The above expression implies that a changing magnetic flux will induce a non-conservative electric field which can vary with time. It is important to distinguish between the induced, non-conservative electric field and the conservative electric field which arises from electric charges.

As an example, let's consider a uniform magnetic field which points *into* the page and is confined to a circular region with radius R , as shown in Figure 10.3.1. Suppose the

magnitude of \vec{B} increases with time, *i.e.*, $dB/dt > 0$. Let's find the induced electric field everywhere due to the changing magnetic field.

Since the magnetic field is confined to a circular region, from symmetry arguments we choose the integration path to be a circle of radius r . The magnitude of the induced field \vec{E}_{nc} at all points on a circle is the same. According to Lenz's law, the direction of \vec{E}_{nc} must be such that it would drive the induced current to produce a magnetic field opposing the change in magnetic flux. With the area vector \vec{A} pointing *out* of the page, the magnetic flux is negative or inward. With $dB/dt > 0$, the inward magnetic flux is increasing. Therefore, to counteract this change the induced current must flow counterclockwise to produce more outward flux. The direction of \vec{E}_{nc} is shown in Figure 10.3.1.

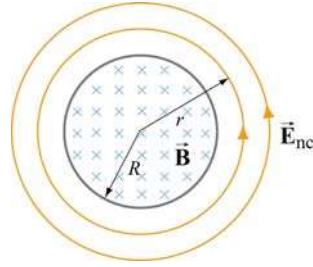

Figure 10.3.1 Induced electric field due to changing magnetic flux

Let's proceed to find the magnitude of \vec{E}_{nc} . In the region $r < R$, the rate of change of magnetic flux is

$$\frac{d\Phi_B}{dt} = \frac{d}{dt}(\vec{B} \cdot \vec{A}) = \frac{d}{dt}(-BA) = -\left(\frac{dB}{dt}\right)\pi r^2 \quad (10.3.4)$$

Using Eq. (10.3.3), we have

$$\oint \vec{E}_{nc} \cdot d\vec{s} = E_{nc}(2\pi r) = -\frac{d\Phi_B}{dt} = \left(\frac{dB}{dt}\right)\pi r^2 \quad (10.3.5)$$

which implies

$$E_{nc} = \frac{r}{2} \frac{dB}{dt} \quad (10.3.6)$$

Similarly, for $r > R$, the induced electric field may be obtained as

$$E_{nc}(2\pi r) = -\frac{d\Phi_B}{dt} = \left(\frac{dB}{dt}\right)\pi R^2 \quad (10.3.7)$$

or

$$E_{nc} = \frac{R^2}{2r} \frac{dB}{dt} \quad (10.3.8)$$

A plot of E_{nc} as a function of r is shown in Figure 10.3.2.

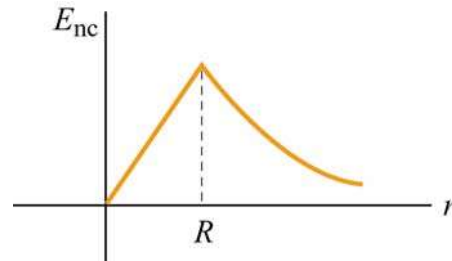

Figure 10.3.2 Induced electric field as a function of r

10.4 Generators

One of the most important applications of Faraday's law of induction is to generators and motors. A generator converts mechanical energy into electric energy, while a motor converts electrical energy into mechanical energy.

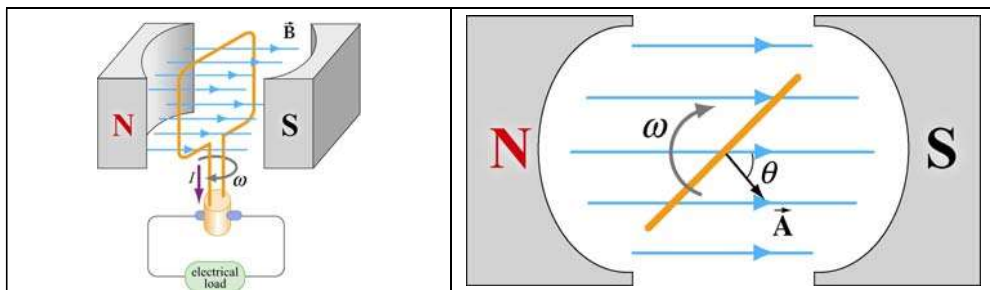

Figure 10.4.1 (a) A simple generator. (b) The rotating loop as seen from above.

Figure 10.4.1(a) is a simple illustration of a generator. It consists of an N -turn loop rotating in a magnetic field which is assumed to be uniform. The magnetic flux varies with time, thereby inducing an emf. From Figure 10.4.1(b), we see that the magnetic flux through the loop may be written as

$$\Phi_B = \vec{\mathbf{B}} \cdot \vec{\mathbf{A}} = BA \cos \theta = BA \cos \omega t \quad (10.4.1)$$

The rate of change of magnetic flux is

$$\frac{d\Phi_B}{dt} = -BA\omega \sin \omega t \quad (10.4.2)$$

Since there are N turns in the loop, the total induced emf across the two ends of the loop is

$$\varepsilon = -N \frac{d\Phi_B}{dt} = NBA\omega \sin \omega t \quad (10.4.3)$$

If we connect the generator to a circuit which has a resistance R , then the current generated in the circuit is given by

$$I = \frac{|\varepsilon|}{R} = \frac{NBA\omega}{R} \sin \omega t \quad (10.4.4)$$

The current is an alternating current which oscillates in sign and has an amplitude $I_0 = NBA\omega / R$. The power delivered to this circuit is

$$P = I |\varepsilon| = \frac{(NBA\omega)^2}{R} \sin^2 \omega t \quad (10.4.5)$$

On the other hand, the torque exerted on the loop is

$$\tau = \mu B \sin \theta = \mu B \sin \omega t \quad (10.4.6)$$

Thus, the mechanical power supplied to rotate the loop is

$$P_m = \tau \omega = \mu B \omega \sin \omega t \quad (10.4.7)$$

Since the dipole moment for the N -turn current loop is

$$\mu = NIA = \frac{N^2 A^2 B \omega}{R} \sin \omega t \quad (10.4.8)$$

the above expression becomes

$$P_m = \left(\frac{N^2 A^2 B \omega}{R} \sin \omega t \right) B \omega \sin \omega t = \frac{(NAB\omega)^2}{R} \sin^2 \omega t \quad (10.4.9)$$

As expected, the mechanical power put in is equal to the electrical power output.

10.5 Eddy Currents

We have seen that when a conducting loop moves through a magnetic field, current is induced as the result of changing magnetic flux. If a solid conductor were used instead of a loop, as shown in Figure 10.5.1, current can also be induced. The induced current appears to be circulating and is called an *eddy current*.

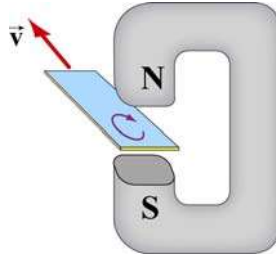

Figure 10.5.1 Appearance of an eddy current when a solid conductor moves through a magnetic field.

The induced eddy currents also generate a magnetic force that opposes the motion, making it more difficult to move the conductor across the magnetic field (Figure 10.5.2).

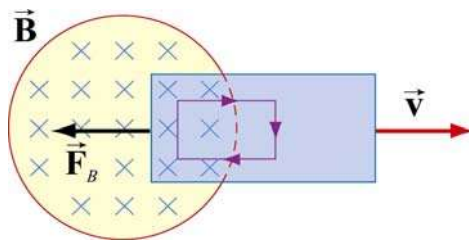

Figure 10.5.2 Magnetic force arising from the eddy current that opposes the motion of the conducting slab.

Since the conductor has non-vanishing resistance R , Joule heating causes a loss of power by an amount $P = \varepsilon^2 / R$. Therefore, by increasing the value of R , power loss can be reduced. One way to increase R is to laminate the conducting slab, or construct the slab by using gluing together thin strips that are insulated from one another (see Figure 10.5.3a). Another way is to make cuts in the slab, thereby disrupting the conducting path (Figure 10.5.3b).

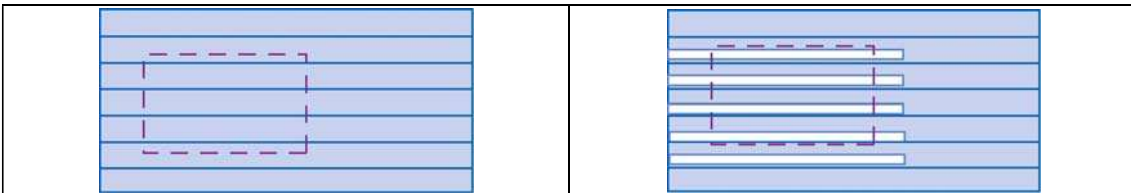

Figure 10.5.3 Eddy currents can be reduced by (a) laminating the slab, or (b) making cuts on the slab.

There are important applications of eddy currents. For example, the currents can be used to suppress unwanted mechanical oscillations. Another application is the magnetic braking systems in high-speed transit cars.

10.6 Summary

- The **magnetic flux** through a surface S is given by

$$\Phi_B = \iint_S \vec{\mathbf{B}} \cdot d\vec{\mathbf{A}}$$

- **Faraday's law** of induction states that the induced emf \mathcal{E} in a coil is proportional to the negative of the rate of change of magnetic flux:

$$\mathcal{E} = -N \frac{d\Phi_B}{dt}$$

- The direction of the induced current is determined by **Lenz's law** which states that the induced current produces magnetic fields which tend to oppose the changes in magnetic flux that induces such currents.
- A **motional emf** \mathcal{E} is induced if a conductor moves in a magnetic field. The general expression for \mathcal{E} is

$$\mathcal{E} = \oint (\vec{\mathbf{v}} \times \vec{\mathbf{B}}) \cdot d\vec{\mathbf{s}}$$

In the case of a conducting bar of length l moving with constant velocity $\vec{\mathbf{v}}$ through a magnetic field which points in the direction perpendicular to the bar and $\vec{\mathbf{v}}$, the induced emf is $\mathcal{E} = -Bvl$.

- An induced emf in a stationary conductor is associated with a **non-conservative electric field** $\vec{\mathbf{E}}_{\text{nc}}$:

$$\mathcal{E} = \oint \vec{\mathbf{E}}_{\text{nc}} \cdot d\vec{\mathbf{s}} = -\frac{d\Phi_B}{dt}$$

10.7 Appendix: Induced Emf and Reference Frames

In Section 10.2, we have stated that the general equation of motional emf is given by

$$\mathcal{E} = \oint (\vec{\mathbf{v}} \times \vec{\mathbf{B}}) \cdot d\vec{\mathbf{s}}$$

where \vec{v} is the velocity of the length element $d\vec{s}$ of the *moving* conductor. In addition, we have also shown in Section 10.4 that induced emf associated with a *stationary* conductor may be written as the line integral of the non-conservative electric field:

$$\varepsilon = \oint \vec{E}_{\text{nc}} \cdot d\vec{s}$$

However, whether an object is moving or stationary actually depends on the reference frame. As an example, let's examine the situation where a bar magnet is approaching a conducting loop. An observer O in the rest frame of the loop sees the bar magnet moving toward the loop. An electric field \vec{E}_{nc} is induced to drive the current around the loop, and a charge on the loop experiences an electric force $\vec{F}_e = q\vec{E}_{\text{nc}}$. Since the charge is at rest according to observer O , no magnetic force is present. On the other hand, an observer O' in the rest frame of the bar magnet sees the loop moving toward the magnet. Since the conducting loop is moving with a velocity \vec{v} , a motional emf is induced. In this frame, O' sees the charge q moving with a velocity \vec{v} , and concludes that the charge experiences a magnetic force $\vec{F}_B = q\vec{v} \times \vec{B}$.

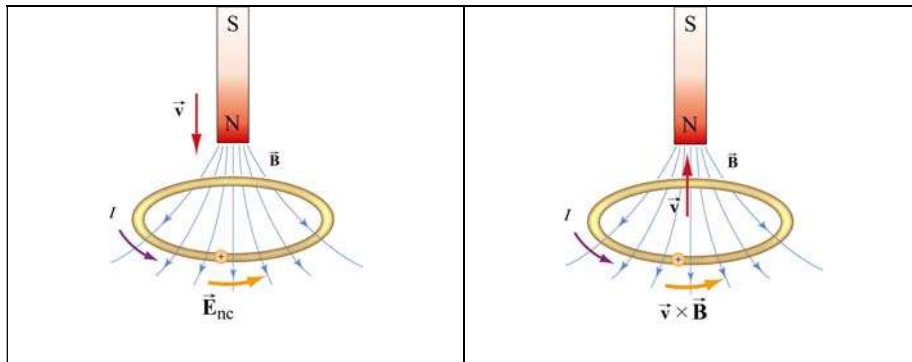

Figure 10.7.1 Induction observed in different reference frames. In (a) the bar magnet is moving, while in (b) the conducting loop is moving.

Since the event seen by the two observer is the same except the choice of reference frames, the force acting on the charge must be the same, $\vec{F}_e = \vec{F}_B$, which implies

$$\vec{E}_{\text{nc}} = \vec{v} \times \vec{B} \quad (10.7.1)$$

In general, as a consequence of relativity, an electric phenomenon observed in a reference frame O may appear to be a magnetic phenomenon in a frame O' that moves at a speed v relative to O .

10.8 Problem-Solving Tips: Faraday's Law and Lenz's Law

In this chapter we have seen that a changing magnetic flux induces an emf:

$$\mathcal{E} = -N \frac{d\Phi_B}{dt}$$

according to Faraday's law of induction. For a conductor which forms a closed loop, the emf sets up an induced current $I = |\mathcal{E}| / R$, where R is the resistance of the loop. To compute the induced current and its direction, we follow the procedure below:

1. For the closed loop of area A on a plane, define an area vector $\vec{\mathbf{A}}$ and let it point in the direction of your thumb, for the convenience of applying the right-hand rule later. Compute the magnetic flux through the loop using

$$\Phi_B = \begin{cases} \vec{\mathbf{B}} \cdot \vec{\mathbf{A}} & (\vec{\mathbf{B}} \text{ is uniform}) \\ \iint \vec{\mathbf{B}} \cdot d\vec{\mathbf{A}} & (\vec{\mathbf{B}} \text{ is non-uniform}) \end{cases}$$

Determine the sign of Φ_B .

2. Evaluate the rate of change of magnetic flux $d\Phi_B / dt$. Keep in mind that the change could be caused by

- (i) changing the magnetic field $dB / dt \neq 0$,
- (ii) changing the loop area if the conductor is moving ($dA / dt \neq 0$), or
- (iii) changing the orientation of the loop with respect to the magnetic field ($d\theta / dt \neq 0$).

Determine the sign of $d\Phi_B / dt$.

3. The sign of the induced emf is the opposite of that of $d\Phi_B / dt$. The direction of the induced current can be found by using Lenz's law discussed in Section 10.1.2.

10.9 Solved Problems

10.9.1 Rectangular Loop Near a Wire

An infinite straight wire carries a current I is placed to the left of a rectangular loop of wire with width w and length l , as shown in the Figure 10.9.1.

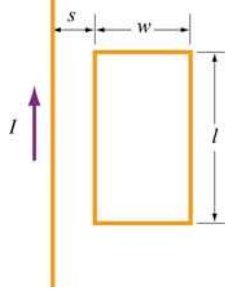

Figure 10.9.1 Rectangular loop near a wire

- (a) Determine the magnetic flux through the rectangular loop due to the current I .
- (b) Suppose that the current is a function of time with $I(t) = a + bt$, where a and b are positive constants. What is the induced emf in the loop and the direction of the induced current?

Solutions:

- (a) Using Ampere's law:

$$\oint \vec{\mathbf{B}} \cdot d\vec{\mathbf{s}} = \mu_0 I_{\text{enc}} \quad (10.9.1)$$

the magnetic field due to a current-carrying wire at a distance r away is

$$B = \frac{\mu_0 I}{2\pi r} \quad (10.9.2)$$

The total magnetic flux Φ_B through the loop can be obtained by summing over contributions from all differential area elements $dA = l dr$:

$$\Phi_B = \int d\Phi_B = \int \vec{\mathbf{B}} \cdot d\vec{\mathbf{A}} = \frac{\mu_0 I l}{2\pi} \int_s^{s+w} \frac{dr}{r} = \frac{\mu_0 I l}{2\pi} \ln\left(\frac{s+w}{s}\right) \quad (10.9.3)$$

Note that we have chosen the area vector to point *into* the page, so that $\Phi_B > 0$.

- (b) According to Faraday's law, the induced emf is

$$\mathcal{E} = -\frac{d\Phi_B}{dt} = -\frac{d}{dt} \left[\frac{\mu_0 I l}{2\pi} \ln\left(\frac{s+w}{s}\right) \right] = -\frac{\mu_0 l}{2\pi} \ln\left(\frac{s+w}{s}\right) \cdot \frac{dI}{dt} = -\frac{\mu_0 b l}{2\pi} \ln\left(\frac{s+w}{s}\right) \quad (10.9.4)$$

where we have used $dI/dt = b$.

The straight wire carrying a current I produces a magnetic flux into the page through the rectangular loop. By Lenz's law, the induced current in the loop must be flowing *counterclockwise* in order to produce a magnetic field out of the page to counteract the increase in inward flux.

10.9.2 Loop Changing Area

A square loop with length l on each side is placed in a uniform magnetic field pointing into the page. During a time interval Δt , the loop is pulled from its two edges and turned into a rhombus, as shown in the Figure 10.9.2. Assuming that the total resistance of the loop is R , find the average induced current in the loop and its direction.

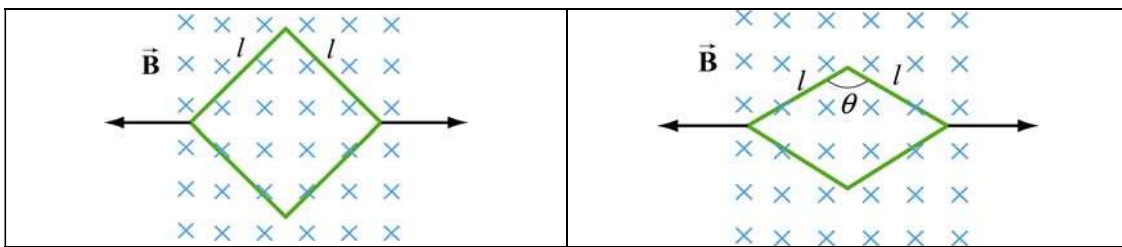

Figure 10.9.2 Conducting loop changing area

Solution:

Using Faraday's law, we have

$$\mathcal{E} = -\frac{\Delta\Phi_B}{\Delta t} = -B\left(\frac{\Delta A}{\Delta t}\right) \quad (10.9.5)$$

Since the initial and the final areas of the loop are $A_i = l^2$ and $A_f = l^2 \sin \theta$, respectively (recall that the area of a parallelogram defined by two vectors \vec{l}_1 and \vec{l}_2 is $A = |\vec{l}_1 \times \vec{l}_2| = l_1 l_2 \sin \theta$), the average rate of change of area is

$$\frac{\Delta A}{\Delta t} = \frac{A_f - A_i}{\Delta t} = -\frac{l^2(1 - \sin \theta)}{\Delta t} < 0 \quad (10.9.6)$$

which gives

$$\mathcal{E} = \frac{Bl^2(1 - \sin \theta)}{\Delta t} > 0 \quad (10.9.7)$$

Thus, the average induced current is

$$I = \frac{\varepsilon}{R} = \frac{Bl^2(1 - \sin \theta)}{\Delta t R} \quad (10.9.8)$$

Since $(\Delta A / \Delta t) < 0$, the magnetic flux into the page decreases. Hence, the current flows in the clockwise direction to compensate the loss of flux.

10.9.3 Sliding Rod

A conducting rod of length l is free to slide on two parallel conducting bars as in Figure 10.9.3.

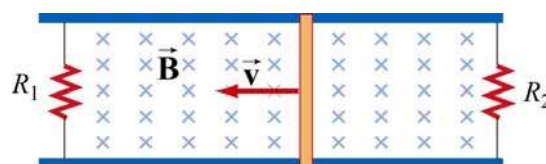

Figure 10.9.3 Sliding rod

In addition, two resistors R_1 and R_2 are connected across the ends of the bars. There is a uniform magnetic field pointing into the page. Suppose an external agent pulls the bar to the left at a constant speed v . Evaluate the following quantities:

- The currents through both resistors;
- The total power delivered to the resistors;
- The applied force needed for the rod to maintain a constant velocity.

Solutions:

(a) The emf induced between the ends of the moving rod is

$$\varepsilon = -\frac{d\Phi_B}{dt} = -Blv \quad (10.9.9)$$

The currents through the resistors are

$$I_1 = \frac{|\varepsilon|}{R_1}, \quad I_2 = \frac{|\varepsilon|}{R_2} \quad (10.9.10)$$

Since the flux into the page for the left loop is decreasing, I_1 flows clockwise to produce a magnetic field pointing into the page. On the other hand, the flux into the page for the right loop is increasing. To compensate the change, according to Lenz's law, I_2 must flow counterclockwise to produce a magnetic field pointing out of the page.

(b) The total power dissipated in the two resistors is

$$P_R = I_1 |\varepsilon| + I_2 |\varepsilon| = (I_1 + I_2) |\varepsilon| = \varepsilon^2 \left(\frac{1}{R_1} + \frac{1}{R_2} \right) = B^2 l^2 v^2 \left(\frac{1}{R_1} + \frac{1}{R_2} \right) \quad (10.9.11)$$

(c) The total current flowing through the rod is $I = I_1 + I_2$. Thus, the magnetic force acting on the rod is

$$F_B = IlB = |\varepsilon| lB \left(\frac{1}{R_1} + \frac{1}{R_2} \right) = B^2 l^2 v \left(\frac{1}{R_1} + \frac{1}{R_2} \right) \quad (10.9.12)$$

and the direction is to the right. Thus, an external agent must apply an equal but opposite force $\vec{F}_{\text{ext}} = -\vec{F}_B$ to the left in order to maintain a constant speed.

Alternatively, we note that since the power dissipated in the resistors must be equal to P_{ext} , the mechanical power supplied by the external agent. The same result is obtained since

$$P_{\text{ext}} = \vec{F}_{\text{ext}} \cdot \vec{v} = F_{\text{ext}} v \quad (10.9.13)$$

10.9.4 Moving Bar

A conducting rod of length l moves with a constant velocity \vec{v} perpendicular to an infinitely long, straight wire carrying a current I , as shown in the Figure 10.9.4. What is the emf generated between the ends of the rod?

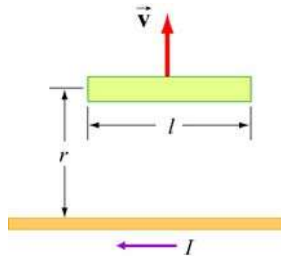

Figure 10.9.4 A bar moving away from a current-carrying wire

Solution:

From Faraday's law, the motional emf is

$$|\varepsilon| = Blv \quad (10.9.14)$$

where v is the speed of the rod. However, the magnetic field due to the straight current-carrying wire at a distance r away is, using Ampere's law:

$$B = \frac{\mu_0 I}{2\pi r} \quad (10.9.15)$$

Thus, the emf between the ends of the rod is given by

$$|\mathcal{E}| = \left(\frac{\mu_0 I}{2\pi r} \right) l v \quad (10.9.16)$$

10.9.5 Time-Varying Magnetic Field

A circular loop of wire of radius a is placed in a uniform magnetic field, with the plane of the loop perpendicular to the direction of the field, as shown in Figure 10.9.5.

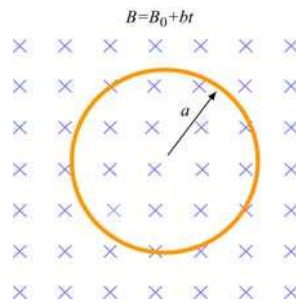

Figure 10.9.5 Circular loop in a time-varying magnetic field

The magnetic field varies with time according to $B(t) = B_0 + bt$, where B_0 and b are positive constants.

- Calculate the magnetic flux through the loop at $t = 0$.
- Calculate the induced emf in the loop.
- What is the induced current and its direction of flow if the overall resistance of the loop is R ?
- Find the power dissipated due to the resistance of the loop.

Solution:

- The magnetic flux at time t is given by

$$\Phi_B = BA = (B_0 + bt)(\pi a^2) = \pi(B_0 + bt)a^2 \quad (10.9.17)$$

where we have chosen the area vector to point *into* the page, so that $\Phi_B > 0$. At $t = 0$, we have

$$\Phi_B = \pi B_0 a^2 \quad (10.9.18)$$

(b) Using Faraday's Law, the induced emf is

$$\varepsilon = -\frac{d\Phi_B}{dt} = -A\frac{dB}{dt} = -(\pi a^2)\frac{d(B_0 + bt)}{dt} = -\pi b a^2 \quad (10.9.19)$$

(c) The induced current is

$$I = \frac{|\varepsilon|}{R} = \frac{\pi b a^2}{R} \quad (10.9.20)$$

and its direction is counterclockwise by Lenz's law.

(d) The power dissipated due to the resistance R is

$$P = I^2 R = \left(\frac{\pi b a^2}{R}\right)^2 R = \frac{(\pi b a^2)^2}{R} \quad (10.9.21)$$

10.9.6 Moving Loop

A rectangular loop of dimensions l and w moves with a constant velocity \vec{v} away from an infinitely long straight wire carrying a current I in the plane of the loop, as shown in Figure 10.9.6. Let the total resistance of the loop be R . What is the current in the loop at the instant the near side is a distance r from the wire?

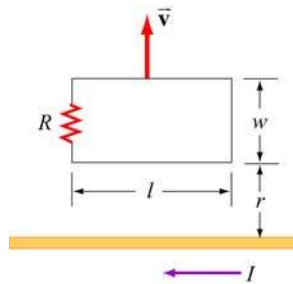

Figure 10.9.6 A rectangular loop moving away from a current-carrying wire

Solution:

The magnetic field at a distance s from the straight wire is, using Ampere's law:

$$B = \frac{\mu_0 I}{2\pi s} \quad (10.9.22)$$

The magnetic flux through a differential area element $dA = l ds$ of the loop is

$$d\Phi_B = \vec{\mathbf{B}} \cdot d\vec{\mathbf{A}} = \frac{\mu_0 I}{2\pi s} l ds \quad (10.9.23)$$

where we have chosen the area vector to point *into* the page, so that $\Phi_B > 0$. Integrating over the entire area of the loop, the total flux is

$$\Phi_B = \frac{\mu_0 I l}{2\pi} \int_r^{r+w} \frac{ds}{s} = \frac{\mu_0 I l}{2\pi} \ln\left(\frac{r+w}{r}\right) \quad (10.9.24)$$

Differentiating with respect to t , we obtain the induced emf as

$$\varepsilon = -\frac{d\Phi_B}{dt} = -\frac{\mu_0 I l}{2\pi} \frac{d}{dt} \left(\ln \frac{r+w}{r} \right) = -\frac{\mu_0 I l}{2\pi} \left(\frac{1}{r+w} - \frac{1}{r} \right) \frac{dr}{dt} = \frac{\mu_0 I l}{2\pi} \frac{vw}{r(r+w)} \quad (10.9.25)$$

where $v = dr/dt$. Notice that the induced emf can also be obtained by using Eq. (10.2.2):

$$\begin{aligned} \varepsilon &= \oint (\vec{\mathbf{v}} \times \vec{\mathbf{B}}) \cdot d\vec{\mathbf{s}} = vl [B(r) - B(r+w)] = vl \left[\frac{\mu_0 I}{2\pi r} - \frac{\mu_0 I}{2\pi(r+w)} \right] \\ &= \frac{\mu_0 I l}{2\pi} \frac{vw}{r(r+w)} \end{aligned} \quad (10.9.26)$$

The induced current is

$$I = \frac{|\varepsilon|}{R} = \frac{\mu_0 I l}{2\pi R} \frac{vw}{r(r+w)} \quad (10.9.27)$$

10.10 Conceptual Questions

1. A bar magnet falls through a circular loop, as shown in Figure 10.10.1

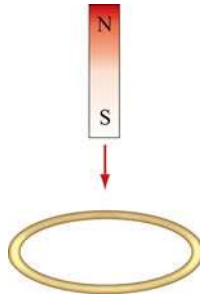

Figure 10.10.1

(a) Describe qualitatively the change in magnetic flux through the loop when the bar magnet is above and below the loop.

(b) Make a qualitative sketch of the graph of the induced current in the loop as a function of time, choosing I to be positive when its direction is counterclockwise as viewed from above.

2. Two circular loops A and B have their planes parallel to each other, as shown in Figure 10.10.2.

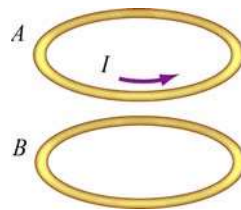

Figure 10.10.2

Loop A has a current moving in the counterclockwise direction, viewed from above.

(a) If the current in loop A decreases with time, what is the direction of the induced current in loop B ? Will the two loops attract or repel each other?

(b) If the current in loop A increases with time, what is the direction of the induced current in loop B ? Will the two loops attract or repel each other?

3. A spherical conducting shell is placed in a time-varying magnetic field. Is there an induced current along the equator?

4. A rectangular loop moves across a uniform magnetic field but the induced current is zero. How is this possible?

10.11 Additional Problems

10.11.1 Sliding Bar

A conducting bar of mass m and resistance R slides on two frictionless parallel rails that are separated by a distance ℓ and connected by a battery which maintains a constant emf \mathcal{E} , as shown in Figure 10.11.1.

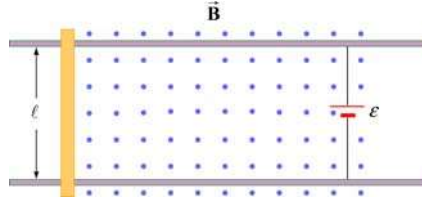

Figure 10.11.1 Sliding bar

A uniform magnetic field \vec{B} is directed out of the page. The bar is initially at rest. Show that at a later time t , the speed of the bar is

$$v = \frac{\mathcal{E}}{B\ell} (1 - e^{-t/\tau})$$

where $\tau = mR / B^2 \ell^2$.

10.11.2 Sliding Bar on Wedges

A conducting bar of mass m and resistance R slides down two frictionless conducting rails which make an angle θ with the horizontal, and are separated by a distance ℓ , as shown in Figure 10.11.2. In addition, a uniform magnetic field \vec{B} is applied vertically downward. The bar is released from rest and slides down.

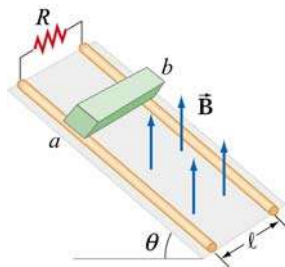

Figure 10.11.2 Sliding bar on wedges

(a) Find the induced current in the bar. Which way does the current flow, from a to b or b to a ?

(b) Find the terminal speed v_t of the bar.

After the terminal speed has been reached,

(c) What is the induced current in the bar?

- (d) What is the rate at which electrical energy has been dissipated through the resistor?
- (e) What is the rate of work done by gravity on the bar?

10.11.3 RC Circuit in a Magnetic Field

Consider a circular loop of wire of radius r lying in the xy plane, as shown in Figure 10.11.3. The loop contains a resistor R and a capacitor C , and is placed in a uniform magnetic field which points into the page and decreases at a rate $dB/dt = -\alpha$, with $\alpha > 0$.

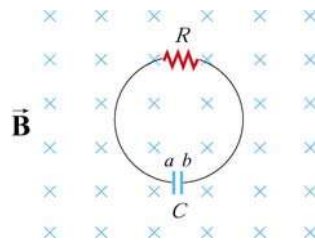

Figure 10.11.3 RC circuit in a magnetic field

- (a) Find the maximum amount of charge on the capacitor.
- (b) Which plate, a or b , has a higher potential? What causes charges to separate?

10.11.4 Sliding Bar

A conducting bar of mass m and resistance R is pulled in the horizontal direction across two frictionless parallel rails a distance ℓ apart by a massless string which passes over a frictionless pulley and is connected to a block of mass M , as shown in Figure 10.11.4. A uniform magnetic field is applied vertically upward. The bar is released from rest.

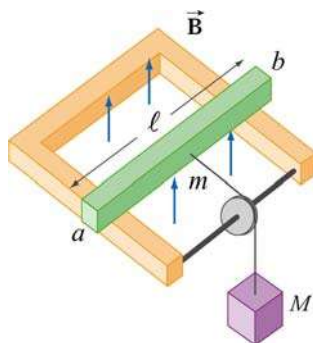

Figure 10.11.4 Sliding bar

- (a) Let the speed of the bar at some instant be v . Find an expression for the induced current. Which direction does it flow, from a to b or b to a ? You may ignore the friction between the bar and the rails.

(b) Solve the differential equation and find the speed of the bar as a function of time.

10.11.5 Rotating Bar

A conducting bar of length l with one end fixed rotates at a constant angular speed ω , in a plane perpendicular to a uniform magnetic field, as shown in Figure 10.11.5.

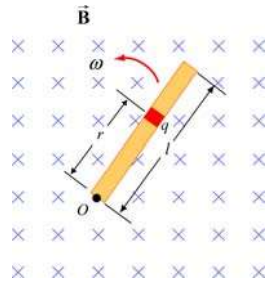

Figure 10.11.5 Rotating bar

(a) A small element carrying charge q is located at a distance r away from the pivot point O . Show that the magnetic force on the element is $F_B = qBr\omega$.

(b) Show that the potential difference between the two ends of the bar is $\Delta V = \frac{1}{2} B\omega l^2$.

10.11.6 Rectangular Loop Moving Through Magnetic Field

A small rectangular loop of length $l = 10$ cm and width $w = 8.0$ cm with resistance $R = 2.0 \Omega$ is pulled at a constant speed $v = 2.0$ cm/s through a region of uniform magnetic field $B = 2.0$ T, pointing into the page, as shown in Figure 10.11.6.

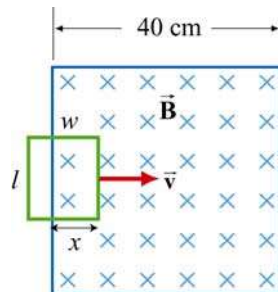

Figure 10.11.6

At $t = 0$, the front of the rectangular loop enters the region of the magnetic field.

(a) Find the magnetic flux and plot it as a function of time (from $t = 0$ till the loop leaves the region of magnetic field.)

(b) Find the emf and plot it as a function of time.

(c) Which way does the induced current flow?

10.11.7 Magnet Moving Through a Coil of Wire

Suppose a bar magnet is pulled through a stationary conducting loop of wire at constant speed, as shown in Figure 10.11.7.

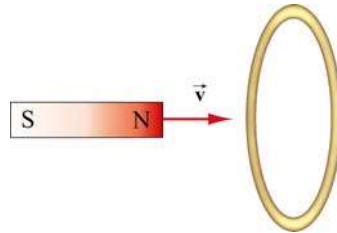

Figure 10.11.7

Assume that the north pole of the magnet enters the loop of wire first, and that the center of the magnet is at the center of the loop at time $t = 0$.

- Sketch qualitatively a graph of the magnetic flux Φ_B through the loop as a function of time.
- Sketch qualitatively a graph of the current I in the loop as a function of time. Take the direction of positive current to be clockwise in the loop as viewed from the left.
- What is the direction of the force on the permanent magnet due to the current in the coil of wire just before the magnet enters the loop?
- What is the direction of the force on the magnet just after it has exited the loop?
- Do your answers in (c) and (d) agree with Lenz's law?
- Where does the energy come from that is dissipated in ohmic heating in the wire?

10.11.8 Alternating-Current Generator

An N -turn rectangular loop of length a and width b is rotated at a frequency f in a uniform magnetic field \vec{B} which points into the page, as shown in Figure 10.11.8. At time $t = 0$, the loop is vertical as shown in the sketch, and it rotates counterclockwise when viewed along the axis of rotation from the left.

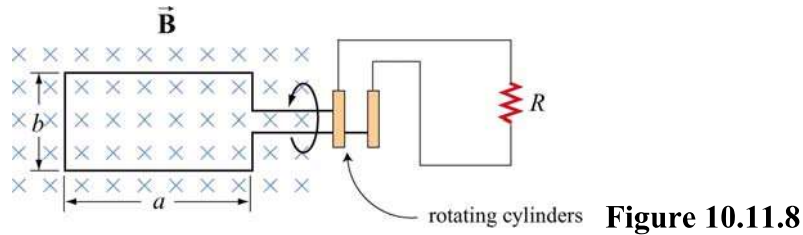

(a) Make a sketch depicting this “generator” as viewed from the left along the axis of rotation at a time Δt shortly after $t = 0$, when it has rotated an angle θ from the vertical. Show clearly the vector \vec{B} , the plane of the loop, and the direction of the induced current.

(b) Write an expression for the magnetic flux Φ_B passing through the loop as a function of time for the given parameters.

(c) Show that an induced emf ε appears in the loop, given by

$$\varepsilon = 2\pi fNbaB \sin(2\pi ft) = \varepsilon_0 \sin(2\pi ft)$$

(d) Design a loop that will produce an emf with $\varepsilon_0 = 120 \text{ V}$ when rotated at 60 revolutions/sec in a magnetic field of 0.40 T.

10.11.9 EMF Due to a Time-Varying Magnetic Field

A uniform magnetic field \vec{B} is perpendicular to a one-turn circular loop of wire of negligible resistance, as shown in Figure 10.11.9. The field changes with time as shown (the z direction is out of the page). The loop is of radius $r = 50 \text{ cm}$ and is connected in series with a resistor of resistance $R = 20 \ \Omega$. The “+” direction around the circuit is indicated in the figure.

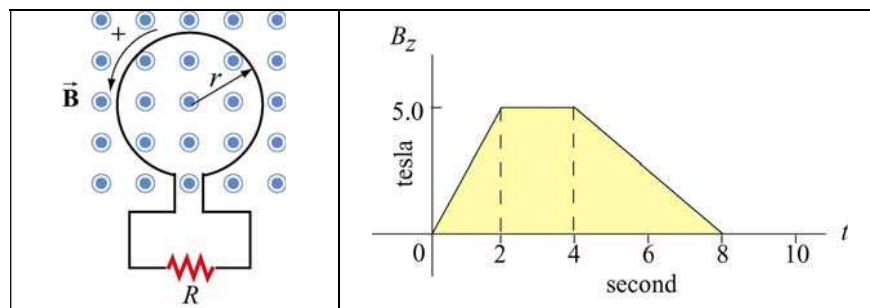

Figure 10.11.9

(a) What is the expression for EMF in this circuit in terms of $B_z(t)$ for this arrangement?

(b) Plot the EMF in the circuit as a function of time. Label the axes quantitatively (numbers and units). Watch the signs. Note that we have labeled the positive direction of the emf in the left sketch consistent with the assumption that positive $\vec{\mathbf{B}}$ is out of the paper. [Partial Ans: values of EMF are 1.96 V, 0.0 V, 0.98 V].

(c) Plot the current I through the resistor R . Label the axes quantitatively (numbers and units). Indicate with arrows on the sketch the *direction* of the current through R during each time interval. [Partial Ans: values of current are 98 mA, 0.0 mA, 49 mA]

(d) Plot the rate of thermal energy production in the resistor. [Partial Ans: values are 192 mW, 0.0 mW, 48 mW].

10.11.10 Square Loop Moving Through Magnetic Field

An external force is applied to move a square loop of dimension $l \times l$ and resistance R at a constant speed across a region of uniform magnetic field. The sides of the square loop make an angle $\theta = 45^\circ$ with the boundary of the field region, as shown in Figure 10.11.10. At $t = 0$, the loop is completely inside the field region, with its right edge at the boundary. Calculate the power delivered by the external force as a function of time.

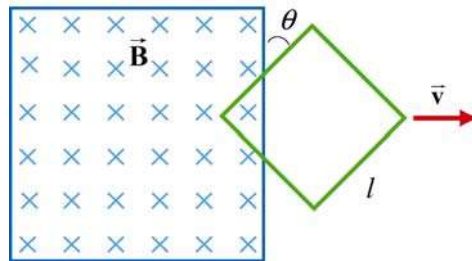

Figure 10.11.10

10.11.11 Falling Loop

A rectangular loop of wire with mass m , width w , vertical length l , and resistance R falls out of a magnetic field under the influence of gravity, as shown in Figure 10.11.11. The magnetic field is uniform and out of the paper ($\vec{\mathbf{B}} = B\hat{\mathbf{i}}$) within the area shown and zero outside of that area. At the time shown in the sketch, the loop is exiting the magnetic field at speed $\vec{\mathbf{v}} = -v\hat{\mathbf{k}}$.

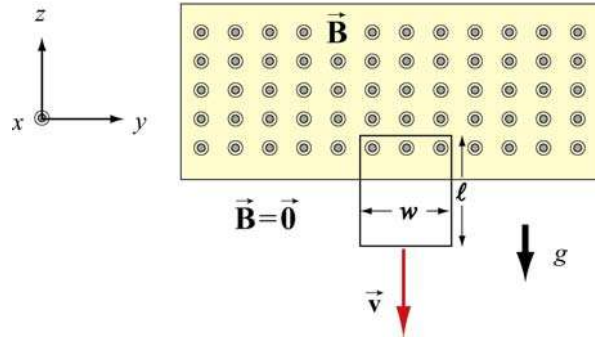

Figure 10.11.11

- What is the direction of the current flowing in the circuit at the time shown, clockwise or counterclockwise? Why did you pick this direction?
- Using Faraday's law, find an expression for the magnitude of the emf in this circuit in terms of the quantities given. What is the magnitude of the current flowing in the circuit at the time shown?
- Besides gravity, what other force acts on the loop in the $\pm \hat{k}$ direction? Give its magnitude and direction in terms of the quantities given.
- Assume that the loop has reached a “terminal velocity” and is no longer accelerating. What is the magnitude of that terminal velocity in terms of given quantities?
- Show that at terminal velocity, the rate at which gravity is doing work on the loop is equal to the rate at which energy is being dissipated in the loop through Joule heating.

Chapter 11

Inductance and Magnetic Energy

11.1 Mutual Inductance	2
Example 11.1 Mutual Inductance of Two Concentric Coplanar Loops	4
11.2 Self-Inductance	4
Example 11.2 Self-Inductance of a Solenoid.....	5
Example 11.3 Self-Inductance of a Toroid.....	6
Example 11.4 Mutual Inductance of a Coil Wrapped Around a Solenoid	7
11.3 Energy Stored in Magnetic Fields	9
Example 11.5 Energy Stored in a Solenoid	10
Animation 11.1: Creating and Destroying Magnetic Energy.....	11
Animation 11.2: Magnets and Conducting Rings	12
11.4 <i>RL</i> Circuits	14
11.4.1 Self-Inductance and the Modified Kirchhoff's Loop Rule.....	14
11.4.2 Rising Current.....	17
11.4.3 Decaying Current.....	19
11.5 <i>LC</i> Oscillations	20
11.6 The <i>RLC</i> Series Circuit.....	25
11.7 Summary.....	27
11.8 Appendix 1: General Solutions for the <i>RLC</i> Series Circuit.....	29
11.8.1 Quality Factor	31
11.9 Appendix 2: Stresses Transmitted by Magnetic Fields	32
Animation 11.3: A Charged Particle in a Time-Varying Magnetic Field.....	36
11.10 Problem-Solving Strategies	37
11.10.1 Calculating Self-Inductance.....	37
11.10.2 Circuits containing inductors	38
11.11 Solved Problems	38
11.11.1 Energy stored in a toroid.....	38
11.11.2 Magnetic Energy Density	39
11.11.3 Mutual Inductance	40
11.11.4 <i>RL</i> Circuit.....	41
11.11.5 <i>RL</i> Circuit.....	43
11.11.6 <i>LC</i> Circuit.....	44
11.12 Conceptual Questions	46

11.13 Additional Problems	47
11.13.1 Solenoid	47
11.13.2 Self-Inductance	47
11.13.3 Coupled Inductors	47
11.13.4 <i>RL</i> Circuit.....	48
11.13.5 <i>RL</i> Circuit.....	49
11.13.6 Inductance of a Solenoid With and Without Iron Core	49
11.13.7 <i>RLC</i> Circuit.....	50
11.13.8 Spinning Cylinder	51
11.13.9 Spinning Loop.....	51

Inductance and Magnetic Energy

11.1 Mutual Inductance

Suppose two coils are placed near each other, as shown in Figure 11.1.1

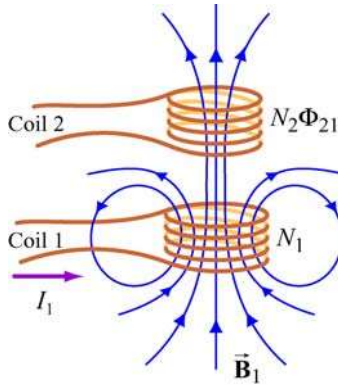

Figure 11.1.1 Changing current in coil 1 produces changing magnetic flux in coil 2.

The first coil has N_1 turns and carries a current I_1 which gives rise to a magnetic field \vec{B}_1 . Since the two coils are close to each other, some of the magnetic field lines through coil 1 will also pass through coil 2. Let Φ_{21} denote the magnetic flux through one turn of coil 2 due to I_1 . Now, by varying I_1 with time, there will be an induced emf associated with the changing magnetic flux in the second coil:

$$\varepsilon_{21} = -N_2 \frac{d\Phi_{21}}{dt} = -\frac{d}{dt} \iint_{\text{coil 2}} \vec{B}_1 \cdot d\vec{A}_2 \quad (11.1.1)$$

The time rate of change of magnetic flux Φ_{21} in coil 2 is proportional to the time rate of change of the current in coil 1:

$$N_2 \frac{d\Phi_{21}}{dt} = M_{21} \frac{dI_1}{dt} \quad (11.1.2)$$

where the proportionality constant M_{21} is called the mutual inductance. It can also be written as

$$M_{21} = \frac{N_2\Phi_{21}}{I_1} \quad (11.1.3)$$

The SI unit for inductance is the henry (H):

$$1 \text{ henry} = 1 \text{ H} = 1 \text{ T} \cdot \text{m}^2/\text{A} \quad (11.1.4)$$

We shall see that the mutual inductance M_{21} depends only on the geometrical properties of the two coils such as the number of turns and the radii of the two coils.

In a similar manner, suppose instead there is a current I_2 in the second coil and it is varying with time (Figure 11.1.2). Then the induced emf in coil 1 becomes

$$\varepsilon_{12} = -N_1 \frac{d\Phi_{12}}{dt} = -\frac{d}{dt} \iint_{\text{coil 1}} \vec{\mathbf{B}}_2 \cdot d\vec{\mathbf{A}}_1 \quad (11.1.5)$$

and a current is induced in coil 1.

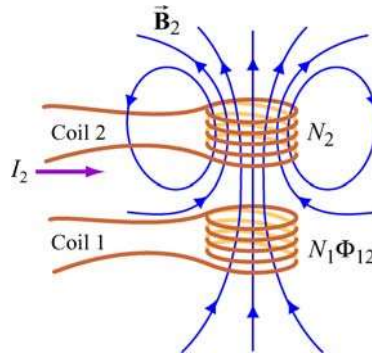

Figure 11.1.2 Changing current in coil 2 produces changing magnetic flux in coil 1.

This changing flux in coil 1 is proportional to the changing current in coil 2,

$$N_1 \frac{d\Phi_{12}}{dt} = M_{12} \frac{dI_2}{dt} \quad (11.1.6)$$

where the proportionality constant M_{12} is another mutual inductance and can be written as

$$M_{12} = \frac{N_1\Phi_{12}}{I_2} \quad (11.1.7)$$

However, using the *reciprocity theorem* which combines Ampere's law and the Biot-Savart law, one may show that the constants are equal:

$$M_{12} = M_{21} \equiv M \quad (11.1.8)$$

Example 11.1 Mutual Inductance of Two Concentric Coplanar Loops

Consider two single-turn co-planar, concentric coils of radii R_1 and R_2 , with $R_1 \gg R_2$, as shown in Figure 11.1.3. What is the mutual inductance between the two loops?

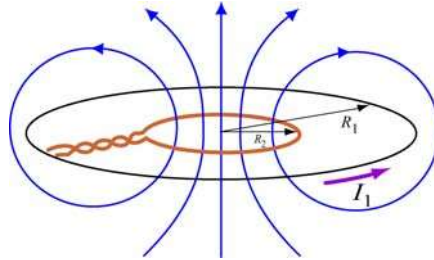

Figure 11.1.3 Two concentric current loop

Solution:

The mutual inductance can be computed as follows. Using Eq. (9.1.15) of Chapter 9, we see that the magnetic field at the center of the ring due to I_1 in the outer coil is given by

$$B_1 = \frac{\mu_0 I_1}{2R_1} \quad (11.1.9)$$

Since $R_1 \gg R_2$, we approximate the magnetic field through the entire inner coil by B_1 . Hence, the flux through the second (inner) coil is

$$\Phi_{21} = B_1 A_2 = \left(\frac{\mu_0 I_1}{2R_1} \right) \pi R_2^2 = \frac{\mu_0 \pi I_1 R_2^2}{2R_1} \quad (11.1.10)$$

Thus, the mutual inductance is given by

$$M = \frac{\Phi_{21}}{I_1} = \frac{\mu_0 \pi R_2^2}{2R_1} \quad (11.1.11)$$

The result shows that M depends only on the geometrical factors, R_1 and R_2 , and is independent of the current I_1 in the coil.

11.2 Self-Inductance

Consider again a coil consisting of N turns and carrying current I in the counterclockwise direction, as shown in Figure 11.2.1. If the current is steady, then the magnetic flux through the loop will remain constant. However, suppose the current I changes with time,

then according to Faraday’s law, an induced emf will arise to oppose the change. The induced current will flow clockwise if $dI/dt > 0$, and counterclockwise if $dI/dt < 0$. The property of the loop in which its own magnetic field opposes any change in current is called “self-inductance,” and the emf generated is called the self-induced emf or back emf, which we denote as ε_L . All current-carrying loops exhibit this property. In particular, an inductor is a circuit element (symbol ) which has a large self-inductance.

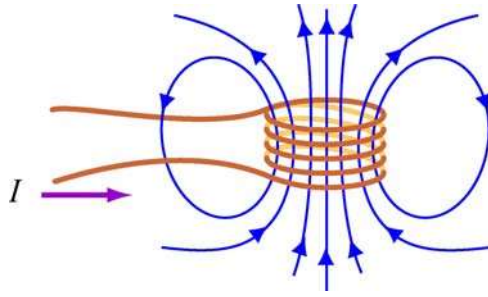

Figure 11.2.1 Magnetic flux through the current loop

Mathematically, the self-induced emf can be written as

$$\varepsilon_L = -N \frac{d\Phi_B}{dt} = -N \frac{d}{dt} \iint \vec{\mathbf{B}} \cdot d\vec{\mathbf{A}} \quad (11.2.1)$$

and is related to the self-inductance L by

$$\varepsilon_L = -L \frac{dI}{dt} \quad (11.2.2)$$

The two expressions can be combined to yield

$$L = \frac{N\Phi_B}{I} \quad (11.2.3)$$

Physically, the inductance L is a measure of an inductor’s “resistance” to the change of current; the larger the value of L , the lower the rate of change of current.

Example 11.2 Self-Inductance of a Solenoid

Compute the self-inductance of a solenoid with N turns, length l , and radius R with a current I flowing through each turn, as shown in Figure 11.2.2.

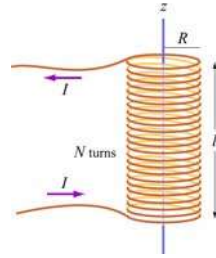

Figure 11.2.2 Solenoid

Solution:

Ignoring edge effects and applying Ampere's law, the magnetic field inside a solenoid is given by Eq. (9.4.3):

$$\vec{\mathbf{B}} = \frac{\mu_0 N I}{l} \hat{\mathbf{k}} = \mu_0 n I \hat{\mathbf{k}} \quad (11.2.4)$$

where $n = N/l$ is the number of turns per unit length. The magnetic flux through each turn is

$$\Phi_B = BA = \mu_0 n I \cdot (\pi R^2) = \mu_0 n I \pi R^2 \quad (11.2.5)$$

Thus, the self-inductance is

$$L = \frac{N \Phi_B}{I} = \mu_0 n^2 \pi R^2 l \quad (11.2.6)$$

We see that L depends only on the geometrical factors (n , R and l) and is independent of the current I .

Example 11.3 Self-Inductance of a Toroid

Calculate the self-inductance of a toroid which consists of N turns and has a rectangular cross section, with inner radius a , outer radius b and height h , as shown in Figure 11.2.3(a).

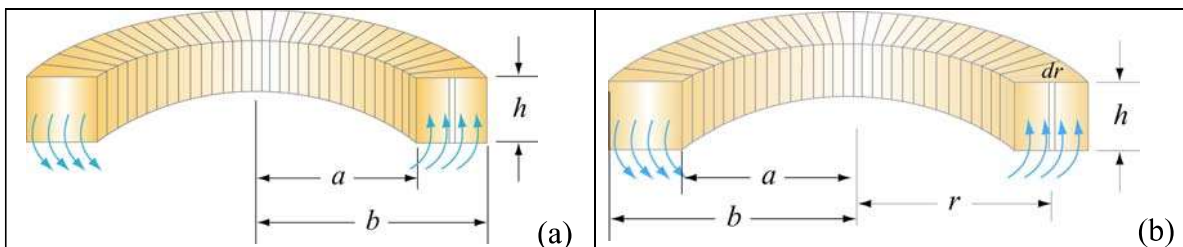

Figure 11.2.3 A toroid with N turns

Solution:

According to Ampere's law discussed in Section 9.3, the magnetic field is given by

$$\oint \vec{\mathbf{B}} \cdot d\vec{\mathbf{s}} = \oint B ds = B \oint ds = B(2\pi r) = \mu_0 NI \quad (11.2.7)$$

or

$$B = \frac{\mu_0 NI}{2\pi r} \quad (11.2.8)$$

The magnetic flux through one turn of the toroid may be obtained by integrating over the rectangular cross section, with $dA = h dr$ as the differential area element (Figure 11.2.3b):

$$\Phi_B = \iint \vec{\mathbf{B}} \cdot d\vec{\mathbf{A}} = \int_a^b \left(\frac{\mu_0 NI}{2\pi r} \right) h dr = \frac{\mu_0 NI h}{2\pi} \ln \left(\frac{b}{a} \right) \quad (11.2.9)$$

The total flux is $N\Phi_B$. Therefore, the self-inductance is

$$L = \frac{N\Phi_B}{I} = \frac{\mu_0 N^2 h}{2\pi} \ln \left(\frac{b}{a} \right) \quad (11.2.10)$$

Again, the self-inductance L depends only on the geometrical factors. Let's consider the situation where $a \gg b - a$. In this limit, the logarithmic term in the equation above may be expanded as

$$\ln \left(\frac{b}{a} \right) = \ln \left(1 + \frac{b-a}{a} \right) \approx \frac{b-a}{a} \quad (11.2.11)$$

and the self-inductance becomes

$$L \approx \frac{\mu_0 N^2 h}{2\pi} \cdot \frac{b-a}{a} = \frac{\mu_0 N^2 h}{2\pi a} = \frac{\mu_0 N^2 A}{l} \quad (11.2.12)$$

where $A = h(b-a)$ is the cross-sectional area, and $l = 2\pi a$. We see that the self-inductance of the toroid in this limit has the same form as that of a solenoid.

Example 11.4 Mutual Inductance of a Coil Wrapped Around a Solenoid

A long solenoid with length l and a cross-sectional area A consists of N_1 turns of wire. An insulated coil of N_2 turns is wrapped around it, as shown in Figure 11.2.4.

(a) Calculate the mutual inductance M , assuming that all the flux from the solenoid passes through the outer coil.

(b) Relate the mutual inductance M to the self-inductances L_1 and L_2 of the solenoid and the coil.

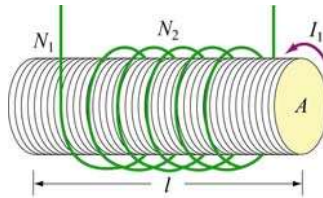

Figure 11.2.4 A coil wrapped around a solenoid

Solutions:

(a) The magnetic flux through each turn of the outer coil due to the solenoid is

$$\Phi_{21} = BA = \frac{\mu_0 N_1 I_1}{l} A \quad (11.2.13)$$

where $B = \mu_0 N_1 I_1 / l$ is the uniform magnetic field inside the solenoid. Thus, the mutual inductance is

$$M = \frac{N_2 \Phi_{21}}{I_1} = \frac{\mu_0 N_1 N_2 A}{l} \quad (11.2.14)$$

(b) From Example 11.2, we see that the self-inductance of the solenoid with N_1 turns is given by

$$L_1 = \frac{N_1 \Phi_{11}}{I_1} = \frac{\mu_0 N_1^2 A}{l} \quad (11.2.15)$$

where Φ_{11} is the magnetic flux through one turn of the solenoid due to the magnetic field produced by I_1 . Similarly, we have $L_2 = \mu_0 N_2^2 A / l$ for the outer coil. In terms of L_1 and L_2 , the mutual inductance can be written as

$$M = \sqrt{L_1 L_2} \quad (11.2.16)$$

More generally the mutual inductance is given by

$$M = k \sqrt{L_1 L_2}, \quad 0 \leq k \leq 1 \quad (11.2.17)$$

where k is the “coupling coefficient.” In our example, we have $k = 1$ which means that all of the magnetic flux produced by the solenoid passes through the outer coil, and vice versa, in this idealization.

11.3 Energy Stored in Magnetic Fields

Since an inductor in a circuit serves to oppose any change in the current through it, work must be done by an external source such as a battery in order to establish a current in the inductor. From the work-energy theorem, we conclude that energy can be stored in an inductor. The role played by an inductor in the magnetic case is analogous to that of a capacitor in the electric case.

The power, or rate at which an external emf ε_{ext} works to overcome the self-induced emf ε_L and pass current I in the inductor is

$$P_L = \frac{dW_{\text{ext}}}{dt} = I\varepsilon_{\text{ext}} \quad (11.3.1)$$

If only the external emf and the inductor are present, then $\varepsilon_{\text{ext}} = -\varepsilon_L$ which implies

$$P_L = \frac{dW_{\text{ext}}}{dt} = -I\varepsilon_L = +IL \frac{dI}{dt} \quad (11.3.2)$$

If the current is increasing with $dI/dt > 0$, then $P > 0$ which means that the external source is doing positive work to transfer energy to the inductor. Thus, the internal energy U_B of the inductor is increased. On the other hand, if the current is decreasing with $dI/dt < 0$, we then have $P < 0$. In this case, the external source takes energy away from the inductor, causing its internal energy to go down. The total work done by the external source to increase the current from zero to I is then

$$W_{\text{ext}} = \int dW_{\text{ext}} = \int_0^I LI' dI' = \frac{1}{2} LI^2 \quad (11.3.3)$$

This is equal to the magnetic energy stored in the inductor:

$$\boxed{U_B = \frac{1}{2} LI^2} \quad (11.3.4)$$

The above expression is analogous to the electric energy stored in a capacitor:

$$U_E = \frac{1}{2} \frac{Q^2}{C} \quad (11.3.5)$$

We comment that from the energy perspective there is an important distinction between an inductor and a resistor. Whenever a current I goes through a resistor, energy flows into the resistor and dissipates in the form of heat regardless of whether I is steady or time-dependent (recall that power dissipated in a resistor is $P_R = IV_R = I^2 R$). On the other hand, energy flows into an ideal inductor only when the current is varying with $dI/dt > 0$. The energy is not dissipated but stored there; it is released later when the current decreases with $dI/dt < 0$. If the current that passes through the inductor is steady, then there is no change in energy since $P_L = LI(dI/dt) = 0$.

Example 11.5 Energy Stored in a Solenoid

A long solenoid with length l and a radius R consists of N turns of wire. A current I passes through the coil. Find the energy stored in the system.

Solution:

Using Eqs. (11.2.6) and (11.3.4), we readily obtain

$$U_B = \frac{1}{2} LI^2 = \frac{1}{2} \mu_0 n^2 I^2 \pi R^2 l \quad (11.3.6)$$

The result can be expressed in terms of the magnetic field strength $B = \mu_0 nI$:

$$U_B = \frac{1}{2\mu_0} (\mu_0 nI)^2 (\pi R^2 l) = \frac{B^2}{2\mu_0} (\pi R^2 l) \quad (11.3.7)$$

Since $\pi R^2 l$ is the volume within the solenoid, and the magnetic field inside is uniform, the term

$$u_B = \frac{B^2}{2\mu_0} \quad (11.3.8)$$

may be identified as the magnetic energy density, or the energy per unit volume of the magnetic field. The above expression holds true even when the magnetic field is non-uniform. The result can be compared with the energy density associated with an electric field:

$$u_E = \frac{1}{2} \epsilon_0 E^2 \quad (11.3.9)$$

Animation 11.1: Creating and Destroying Magnetic Energy

Let's consider the process involved in creating magnetic energy. Figure 11.3.1 shows the process by which an external agent(s) creates magnetic energy. Suppose we have five rings that carry a number of free positive charges that are not moving. Since there is no current, there is no magnetic field. Now suppose a set of external agents come along (one for each charge) and simultaneously spin up the charges counterclockwise as seen from above, at the same time and at the same rate, in a manner that has been pre-arranged. Once the charges on the rings start to accelerate, there is a magnetic field in the space between the rings, mostly parallel to their common axis, which is stronger inside the rings than outside. This is the solenoid configuration.

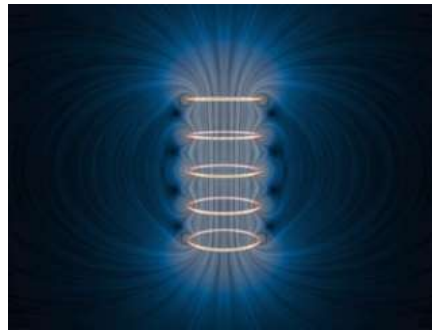

Figure 11.3.1 Creating and destroying magnetic field energy.

As the magnetic flux through the rings grows, Faraday's law of induction tells us that there is an electric field induced by the time-changing magnetic field that is circulating clockwise as seen from above. The force on the charges due to this electric field is thus opposite the direction the external agents are trying to spin the rings up (counterclockwise), and thus the agents have to do additional work to spin up the charges because of their charge. This is the source of the energy that is appearing in the magnetic field between the rings — the work done by the agents against the “back emf.”

Over the course of the “create” animation associated with Figure 11.3.1, the agents moving the charges to a higher speed against the induced electric field are continually doing work. The electromagnetic energy that they are creating at the place where they are doing work (the path along which the charges move) flows both inward and outward. The direction of the flow of this energy is shown by the animated texture patterns in Figure 11.3.1. This is the electromagnetic energy flow that increases the strength of the magnetic field in the space between the rings as each positive charge is accelerated to a higher and higher speed. When the external agents have gotten up the charges to a pre-determined speed, they stop the acceleration. The charges then move at a constant speed, with a constant field inside the solenoid, and zero “induced” electric field, in accordance with Faraday's law of induction.

We also have an animation of the “destroy” process linked to Figure 11.3.1. This process proceeds as follows. Our set of external agents now simultaneously start to spin down the moving charges (which are still moving counterclockwise as seen from above), at the

same time and at the same rate, in a manner that has been pre-arranged. Once the charges on the rings start to decelerate, the magnetic field in the space between the rings starts to decrease in magnitude. As the magnetic flux through the rings decreases, Faraday's law tells us that there is now an electric field induced by the time-changing magnetic field that is circulating counterclockwise as seen from above. The force on the charges due to this electric field is thus in the same direction as the motion of the charges. In this situation the agents have work done on them as they try to spin the charges down.

Over the course of the "destroy" animation associated with Figure 11.3.1, the strength of the magnetic field decreases, and this energy flows from the field back to the path along which the charges move, and is now being provided *to* the agents trying to spin down the moving charges. The energy provided to those agents as they destroy the magnetic field is exactly the amount of energy that they put into creating the magnetic field in the first place, neglecting radiative losses (such losses are small if we move the charges at speeds small compared to the speed of light). This is a totally reversible process if we neglect such losses. That is, the amount of energy the agents put into creating the magnetic field is exactly returned to the agents as the field is destroyed.

There is one final point to be made. Whenever electromagnetic energy is being created, an electric charge is moving (or being moved) against an electric field ($q \vec{v} \cdot \vec{E} < 0$). Whenever electromagnetic energy is being destroyed, an electric charge is moving (or being moved) along an electric field ($q \vec{v} \cdot \vec{E} > 0$). This is the same rule we saw above when we were creating and destroying electric energy above.

Animation 11.2: Magnets and Conducting Rings

In the example of Faraday's law that we gave above, the sense of the electric field associated with a time-changing magnetic field was always such as to try to resist change. We consider another example of Faraday's law that illustrates this same tendency in a different way.

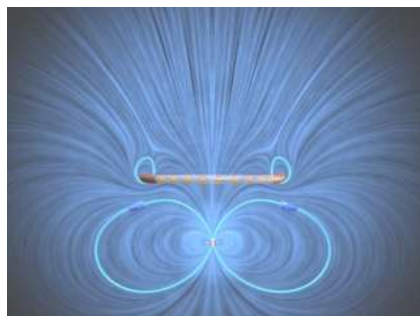

Figure 11.3.2 A perfectly conducting ring falls on the axis of a permanent magnet. The induced currents and the resulting magnetic field stresses are such as to slow the fall of the ring. If the ring is light enough (or the magnet strong enough), the ring will levitate above the magnet.

In Figure 11.3.2, we show a permanent magnet that is fixed at the origin with its dipole moment pointing upward. On the z -axis above the magnet, we have a co-axial, conducting, non-magnetic ring with radius a , inductance L , and resistance R . The center of the conducting ring is constrained to move along the vertical axis. The ring is released from rest and falls under gravity toward the stationary magnet. Eddy currents arise in the ring because of the changing magnetic flux and induced electric field as the ring falls toward the magnet, and the sense of these currents is to repel the ring when it is above the magnet.

This physical situation can be formulated mathematically in terms of three coupled ordinary differential equations for the position of the ring, its velocity, and the current in the ring. We consider in Figure 11.3.2 the particular situation where the resistance of the ring (which in our model can have any value) is identically zero, and the mass of the ring is small enough (or the field of the magnet is large enough) so that the ring levitates above the magnet. We let the ring begin at rest a distance $2a$ above the magnet. The ring begins to fall under gravity. When the ring reaches a distance of about a above the ring, its acceleration slows because of the increasing current in the ring. As the current increases, energy is stored in the magnetic field, and when the ring comes to rest, all of the initial gravitational potential of the ring is stored in the magnetic field. That magnetic energy is then returned to the ring as it “bounces” and returns to its original position a distance $2a$ above the magnet. Because there is no dissipation in the system for our particular choice of R in this example, this motion repeats indefinitely.

What are the important points to be learned from this animation? Initially, all the free energy in this situation is stored in the gravitational potential energy of the ring. As the ring begins to fall, that gravitational energy begins to appear as kinetic energy in the ring. It also begins to appear as energy stored in the magnetic field. The compressed field below the ring enables the transmission of an upward force to the moving ring as well as a downward force to the magnet. But that compression also stores energy in the magnetic field. It is plausible to argue based on the animation that the kinetic energy of the downwardly moving ring is decreasing as more and more energy is stored in the magnetostatic field, and conversely when the ring is rising.

Figure 11.3.3 shows a more realistic case in which the resistance of the ring is finite. Now energy is not conserved, and the ring eventually falls past the magnet. When it passes the magnet, the sense of the induced electric field and thus of the eddy currents reverses, and the ring is now attracted to the magnet above it, which again retards its fall.

There are many other examples of the falling ring and stationary magnet, or falling magnet and stationary ring, given in the animations at this link. All of them show that the effect of the electric field associated with a time-changing magnetic field is to try to keep things the same. In the limiting case of zero resistance, it can in fact achieve this goal, e.g. in Figure 11.3.2 the magnetic flux through the ring never changes over the course of the motion.

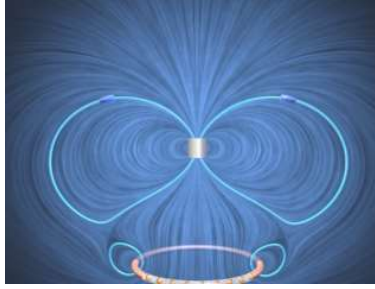

Figure 11.3.3 A ring with finite resistance falls on the axis of a magnet. We show the ring after it has fallen past the magnet, when it is attracted to the magnet above it.

11.4 *RL* Circuits

11.4.1 Self-Inductance and the Modified Kirchhoff's Loop Rule

The addition of time-changing magnetic fields to simple circuits means that the closed line integral of the electric field around a circuit is no longer zero. Instead, we have, for any open surface

$$\oint \vec{E} \cdot d\vec{s} = -\frac{d}{dt} \iint \vec{B} \cdot d\vec{A} \quad (11.4.1)$$

Any circuit where the current changes with time will have time-changing magnetic fields, and therefore induced electric fields. How do we solve simple circuits taking such effects into account? We discuss here a consistent way to understand the consequences of introducing time-changing magnetic fields into circuit theory -- that is, inductance.

As soon as we introduce time-changing magnetic fields, the electric potential difference between two points in our circuit is no longer well-defined, because when the line integral of the electric field around a closed loop is nonzero, the potential difference between two points, say a and b , is no longer independent of the path taken to get from a to b . That is, the electric field is no longer a conservative field, and the electric potential is no longer an appropriate concept, since we can no longer write \vec{E} as the negative gradient of a scalar potential. However, we can still write down in a straightforward fashion the equation that determines the behavior of a circuit.

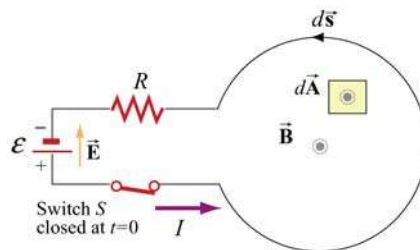

Figure 11.4.1 One-loop inductor circuit

To show how to do this, consider the circuit shown in Figure 11.4.1. We have a battery, a resistor, a switch S that is closed at $t = 0$, and a “one-loop inductor.” It will become clear what the consequences of this “inductance” are as we proceed. For $t > 0$, current will flow in the direction shown (from the positive terminal of the battery to the negative, as usual). What is the equation that governs the behavior of our current $I(t)$ for $t > 0$?

To investigate this, apply Faraday's law to the open surface bounded by our circuit, where we take $d\vec{A}$ to be out of the page, and $d\vec{s}$ right-handed with respect to that choice (counter-clockwise). First, what is the integral of the electric field around this circuit? There is an electric field in the battery, directed from the positive terminal to the negative terminal, and when we go through the battery in the direction of $d\vec{s}$ that we have chosen, we are moving against that electric field, so that $\vec{E} \cdot d\vec{s} < 0$. Thus the contribution of the battery to our integral is $-\varepsilon$. Then, there is an electric field in the resistor, in the direction of the current, so when we move through the resistor in that direction, $\vec{E} \cdot d\vec{s}$ is greater than zero, and that contribution to our integral is $+IR$. What about when we move through our one-loop inductor? There is **no** electric field in this loop if the resistance of the wire making up the loop is zero. Thus, going around the closed loop *clockwise* against the current, we have

$$\oint \vec{E} \cdot d\vec{s} = -\varepsilon + IR \quad (11.4.2)$$

Now, what is the magnetic flux Φ_B through our open surface? First of all, we arrange the geometry so that the part of the circuit which includes the battery, the switch, and the resistor makes only a small contribution to Φ_B as compared to the (much larger in area) part of the open surface which includes our one-loop inductor. Second, we know that Φ_B is positive in that part of the surface, because current flowing counterclockwise will produce a magnetic field \vec{B} pointing out of the page, which is the same direction we have assumed for $d\vec{A}$. Thus, the dot product $\vec{B} \cdot d\vec{A} > 0$. Note that \vec{B} is the *self* magnetic field – that is, the magnetic field produced by the current flowing in the circuit, and not by any external currents.

From Section 11.1, we also see that the magnetic flux Φ_B is proportional to I , and may be written as $\Phi_B = LI$, where L is the self-inductance which depends on the geometry of the circuit. The time rate of change of Φ_B is just $L(dI/dt)$, so that we have from Faraday's law

$$\oint \vec{E} \cdot d\vec{s} = -\varepsilon + IR = -\frac{d\Phi_B}{dt} = -L\frac{dI}{dt} \quad (11.4.3)$$

We can write the governing equation for $I(t)$ from above as

$$\Delta V = \varepsilon - IR - L \frac{dI}{dt} = 0 \quad (11.4.4)$$

where the expression has been cast in a form that resembles Kirchhoff's loop rule, namely that the sum of the potential drops around a circuit is zero. To preserve the loop rule, we must specify the “potential drop” across an inductor.

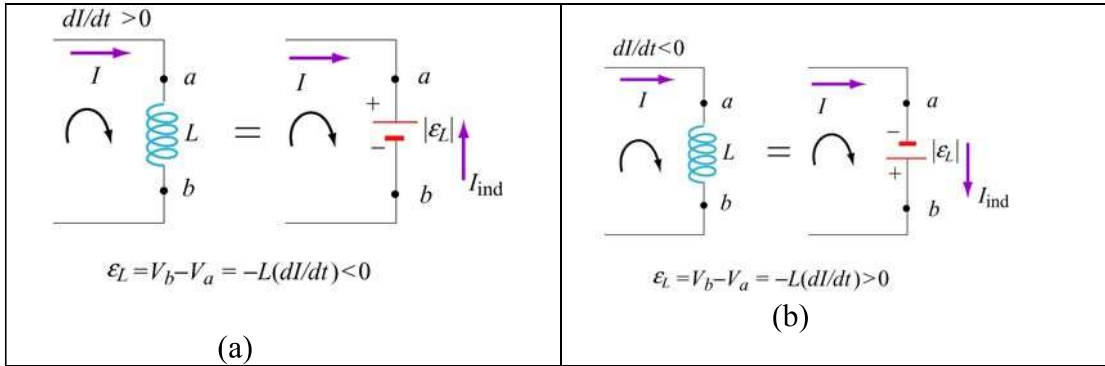

Figure 11.4.2 Modified Kirchhoff's rule for inductors (a) with increasing current, and (b) with decreasing current.

The modified rule for inductors may be obtained as follows: The polarity of the self-induced emf is such as to oppose the change in current, in accord with Lenz's law. If the rate of change of current is positive, as shown in Figure 11.4.2(a), the self-induced emf ε_L sets up an induced current I_{ind} moving in the opposite direction of the current I to oppose such an increase. The inductor could be replaced by an emf $|\varepsilon_L| = L |dI/dt| = +L(dI/dt)$ with the polarity shown in Figure 11.4.2(a). On the other hand, if $dI/dt < 0$, as shown in Figure 11.4.2(b), the induced current I_{ind} set up by the self-induced emf ε_L flows in the same direction as I to oppose such a decrease.

We see that whether the rate of change of current is increasing ($dI/dt > 0$) or decreasing ($dI/dt < 0$), in both cases, the change in potential when moving from a to b along the direction of the current I is $V_b - V_a = -L(dI/dt)$. Thus, we have

Kirchhoff's Loop Rule Modified for Inductors:

If an inductor is traversed in the direction of the current, the “potential change” is $-L(dI/dt)$. On the other hand, if the inductor is traversed in the direction opposite of the current, the “potential change” is $+L(dI/dt)$.

Use of this modified Kirchhoff's rule will give the correct equations for circuit problems that contain inductors. However, keep in mind that it is **misleading** at best, and at some level **wrong** in terms of the physics. Again, we emphasize that Kirchhoff's loop rule was originally based on the fact that the line integral of \vec{E} around a closed loop was zero.

With time-changing magnetic fields, this is no longer so, and thus the sum of the “potential drops” around the circuit, if we take that to mean the negative of the closed loop integral of \vec{E} , is **no longer zero** – in fact it is $+L(dI/dt)$.

11.4.2 Rising Current

Consider the RL circuit shown in Figure 11.4.3. At $t=0$ the switch is closed. We find that the current does not rise immediately to its maximum value ε/R . This is due to the presence of the self-induced emf in the inductor.

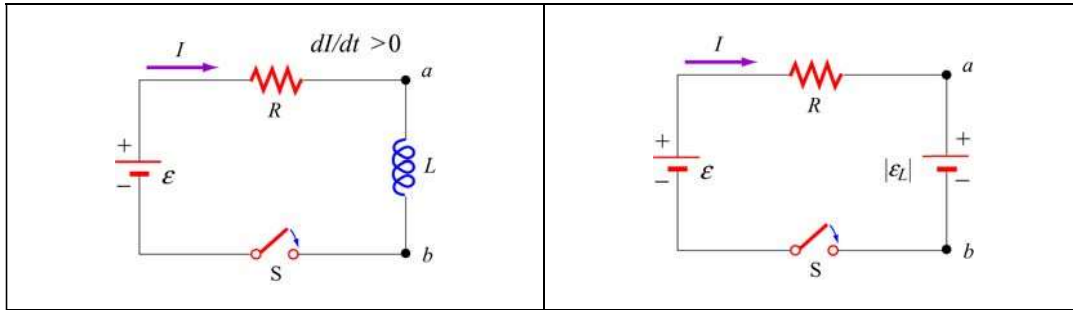

Figure 11.4.3 (a) RL Circuit with rising current. (b) Equivalent circuit using the modified Kirchhoff’s loop rule.

Using the modified Kirchhoff’s rule for increasing current, $dI/dt > 0$, the RL circuit is described by the following differential equation:

$$\varepsilon - IR - |\varepsilon_L| = \varepsilon - IR - L \frac{dI}{dt} = 0 \quad (11.4.5)$$

Note that there is an important distinction between an inductor and a resistor. The potential difference across a resistor depends on I , while the potential difference across an inductor depends on dI/dt . The self-induced emf does not oppose the current itself, but the change of current dI/dt .

The above equation can be rewritten as

$$\frac{dI}{I - \varepsilon/R} = - \frac{dt}{L/R} \quad (11.4.6)$$

Integrating over both sides and imposing the condition $I(t=0)=0$, the solution to the differential equation is

$$I(t) = \frac{\varepsilon}{R} (1 - e^{-t/\tau}) \quad (11.4.7)$$

where

$$\tau = \frac{L}{R} \quad (11.4.8)$$

is the time constant of the RL circuit. The qualitative behavior of the current as a function of time is depicted in Figure 11.4.4.

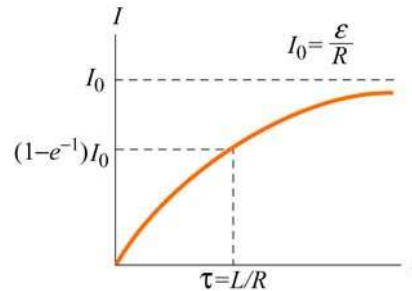

Figure 11.4.4 Current in the RL circuit as a function of time

Note that after a sufficiently long time, the current reaches its equilibrium value ϵ/R . The time constant τ is a measure of how fast the equilibrium state is attained; the larger the value of L , the longer it takes to build up the current. A comparison of the behavior of current in a circuit with or without an inductor is shown in Figure 11.4.5 below.

Similarly, the magnitude of the self-induced emf can be obtained as

$$|\varepsilon_L| = \left| -L \frac{dI}{dt} \right| = \varepsilon e^{-t/\tau} \quad (11.4.9)$$

which is at a maximum when $t = 0$ and vanishes as t approaches infinity. This implies that a sufficiently long time after the switch is closed, self-induction disappears and the inductor simply acts as a conducting wire connecting two parts of the circuit.

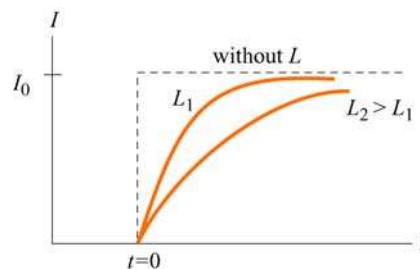

Figure 11.4.5 Behavior of current in a circuit with or without an inductor

To see that energy is conserved in the circuit, we multiply Eq. (11.4.7) by I and obtain

$$I\varepsilon = I^2R + LI \frac{dI}{dt} \quad (11.4.10)$$

The left-hand side represents the rate at which the battery delivers energy to the circuit. On the other hand, the first term on the right-hand side is the power dissipated in the resistor in the form of heat, and the second term is the rate at which energy is stored in the inductor. While the energy dissipated through the resistor is irrecoverable, the magnetic energy stored in the inductor can be released later.

11.4.3 Decaying Current

Next we consider the RL circuit shown in Figure 11.4.6. Suppose the switch S_1 has been closed for a long time so that the current is at its equilibrium value ε/R . What happens to the current when at $t = 0$ switches S_1 is opened and S_2 closed?

Applying modified Kirchhoff's loop rule to the right loop for decreasing current, $dI/dt < 0$, yields

$$|\varepsilon_L| - IR = -L \frac{dI}{dt} - IR = 0 \quad (11.4.11)$$

which can be rewritten as

$$\frac{dI}{I} = - \frac{dt}{L/R} \quad (11.4.12)$$

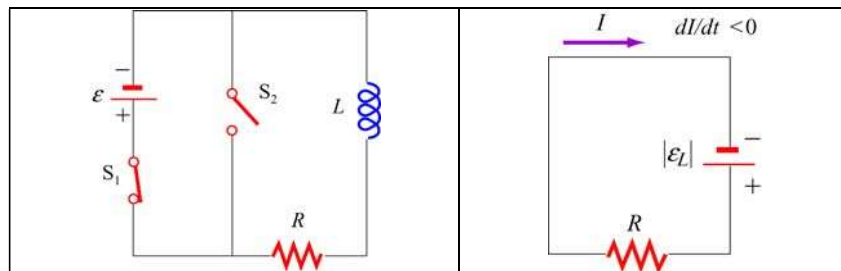

Figure 11.4.6 (a) RL circuit with decaying current, and (b) equivalent circuit.

The solution to the above differential equation is

$$I(t) = \frac{\varepsilon}{R} e^{-t/\tau} \quad (11.4.13)$$

where $\tau = L/R$ is the same time constant as in the case of rising current. A plot of the current as a function of time is shown in Figure 11.4.7.

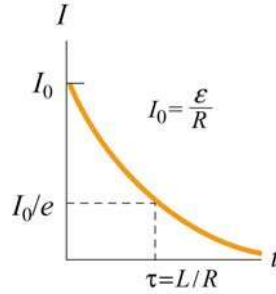

Figure 11.4.7 Decaying current in an RL circuit

11.5 LC Oscillations

Consider an LC circuit in which a capacitor is connected to an inductor, as shown in Figure 11.5.1.

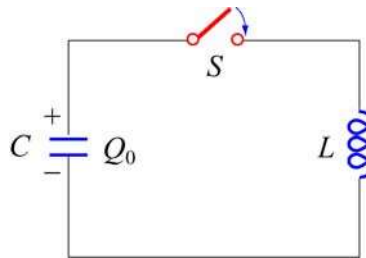

Figure 11.5.1 LC Circuit

Suppose the capacitor initially has charge Q_0 . When the switch is closed, the capacitor begins to discharge and the electric energy is decreased. On the other hand, the current created from the discharging process generates magnetic energy which then gets stored in the inductor. In the absence of resistance, the total energy is transformed back and forth between the electric energy in the capacitor and the magnetic energy in the inductor. This phenomenon is called electromagnetic oscillation.

The total energy in the LC circuit at some instant after closing the switch is

$$U = U_c + U_L = \frac{1}{2} \frac{Q^2}{C} + \frac{1}{2} LI^2 \quad (11.5.1)$$

The fact that U remains constant implies that

$$\frac{dU}{dt} = \frac{d}{dt} \left(\frac{1}{2} \frac{Q^2}{C} + \frac{1}{2} LI^2 \right) = \frac{Q}{C} \frac{dQ}{dt} + LI \frac{dI}{dt} = 0 \quad (11.5.2)$$

or

$$\boxed{\frac{Q}{C} + L \frac{d^2 Q}{dt^2} = 0} \quad (11.5.3)$$

where $I = -dQ/dt$ (and $dI/dt = -d^2Q/dt^2$). Notice the sign convention we have adopted here. The negative sign implies that the current I is equal to the rate of *decrease* of charge in the capacitor plate immediately after the switch has been closed. The same equation can be obtained by applying the modified Kirchhoff's loop rule clockwise:

$$\frac{Q}{C} - L \frac{dI}{dt} = 0 \quad (11.5.4)$$

followed by our definition of current.

The general solution to Eq. (11.5.3) is

$$Q(t) = Q_0 \cos(\omega_0 t + \phi) \quad (11.5.5)$$

where Q_0 is the amplitude of the charge and ϕ is the phase. The angular frequency ω_0 is given by

$$\omega_0 = \frac{1}{\sqrt{LC}} \quad (11.5.6)$$

The corresponding current in the inductor is

$$I(t) = -\frac{dQ}{dt} = \omega_0 Q_0 \sin(\omega_0 t + \phi) = I_0 \sin(\omega_0 t + \phi) \quad (11.5.7)$$

where $I_0 = \omega_0 Q_0$. From the initial conditions $Q(t=0) = Q_0$ and $I(t=0) = 0$, the phase ϕ can be determined to be $\phi = 0$. Thus, the solutions for the charge and the current in our LC circuit are

$$Q(t) = Q_0 \cos \omega_0 t \quad (11.5.8)$$

and

$$I(t) = I_0 \sin \omega_0 t \quad (11.5.9)$$

The time dependence of $Q(t)$ and $I(t)$ are depicted in Figure 11.5.2.

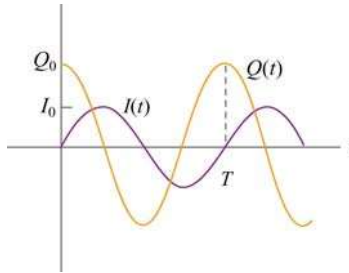

Figure 11.5.2 Charge and current in the LC circuit as a function of time

Using Eqs. (11.5.8) and (11.5.9), we see that at any instant of time, the electric energy and the magnetic energies are given by

$$U_E = \frac{Q^2(t)}{2C} = \left(\frac{Q_0^2}{2C} \right) \cos^2 \omega_0 t \quad (11.5.10)$$

and

$$U_B = \frac{1}{2} LI^2(t) = \frac{LI_0^2}{2} \sin^2 \omega_0 t = \frac{L(-\omega_0 Q_0)^2}{2} \sin^2 \omega_0 t = \left(\frac{Q_0^2}{2C} \right) \sin^2 \omega_0 t \quad (11.5.11)$$

respectively. One can easily show that the total energy remains constant:

$$U = U_E + U_B = \left(\frac{Q_0^2}{2C} \right) \cos^2 \omega_0 t + \left(\frac{Q_0^2}{2C} \right) \sin^2 \omega_0 t = \frac{Q_0^2}{2C} \quad (11.5.12)$$

The electric and magnetic energy oscillation is illustrated in Figure 11.5.3.

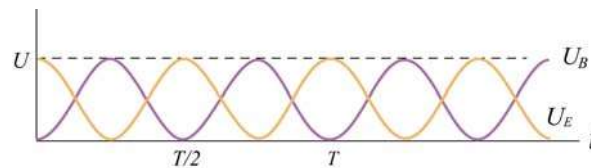

Figure 11.5.3 Electric and magnetic energy oscillations

The mechanical analog of the LC oscillations is the mass-spring system, shown in Figure 11.5.4.

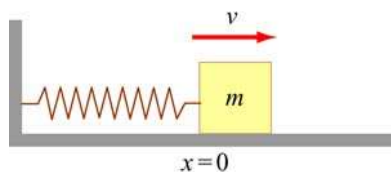

Figure 11.5.4 Mass-spring oscillations

If the mass is moving with a speed v and the spring having a spring constant k is displaced from its equilibrium by x , then the total energy of this mechanical system is

$$U = K + U_{\text{sp}} = \frac{1}{2}mv^2 + \frac{1}{2}kx^2 \quad (11.5.13)$$

where K and U_{sp} are the kinetic energy of the mass and the potential energy of the spring, respectively. In the absence of friction, U is conserved and we obtain

$$\frac{dU}{dt} = \frac{d}{dt} \left(\frac{1}{2}mv^2 + \frac{1}{2}kx^2 \right) = mv \frac{dv}{dt} + kx \frac{dx}{dt} = 0 \quad (11.5.14)$$

Using $v = dx/dt$ and $dv/dt = d^2x/dt^2$, the above equation may be rewritten as

$$\boxed{m \frac{d^2x}{dt^2} + kx = 0} \quad (11.5.15)$$

The general solution for the displacement is

$$x(t) = x_0 \cos(\omega_0 t + \phi) \quad (11.5.16)$$

where

$$\omega_0 = \sqrt{\frac{k}{m}} \quad (11.5.17)$$

is the angular frequency and x_0 is the amplitude of the oscillations. Thus, at any instant in time, the energy of the system may be written as

$$\begin{aligned} U &= \frac{1}{2}mx_0^2\omega_0^2 \sin^2(\omega_0 t + \phi) + \frac{1}{2}kx_0^2 \cos^2(\omega_0 t + \phi) \\ &= \frac{1}{2}kx_0^2 \left[\sin^2(\omega_0 t + \phi) + \cos^2(\omega_0 t + \phi) \right] = \frac{1}{2}kx_0^2 \end{aligned} \quad (11.5.18)$$

In Figure 11.5.5 we illustrate the energy oscillations in the LC Circuit and the mass-spring system (harmonic oscillator).

LC Circuit	Mass-spring System	Energy
		
		
		
		
		

Figure 11.5.5 Energy oscillations in the LC Circuit and the mass-spring system

11.6 The RLC Series Circuit

We now consider a series RLC circuit which contains a resistor, an inductor and a capacitor, as shown in Figure 11.6.1.

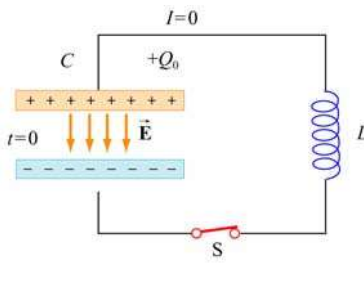
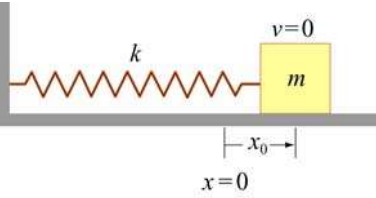
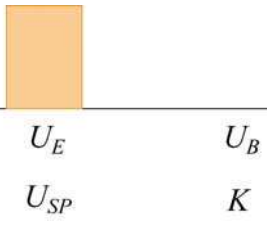
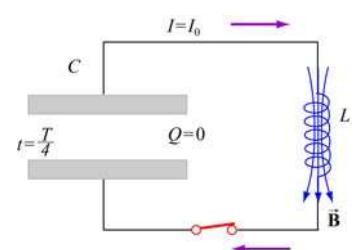
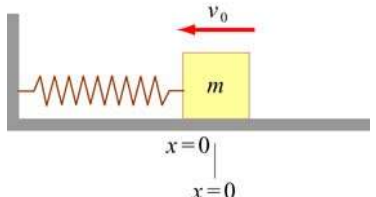
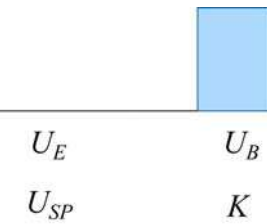
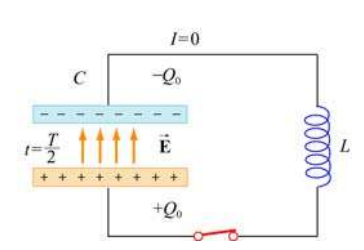
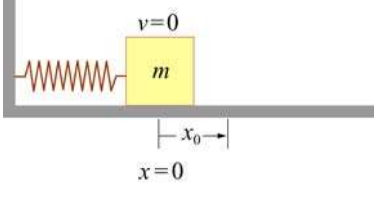
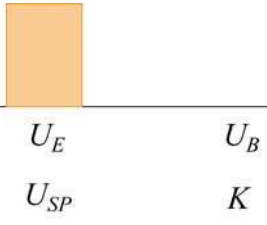
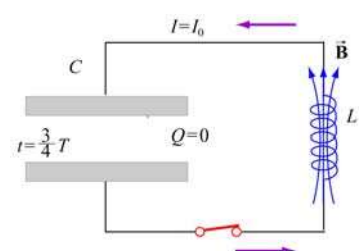
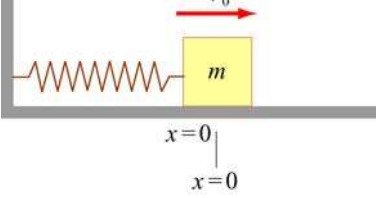
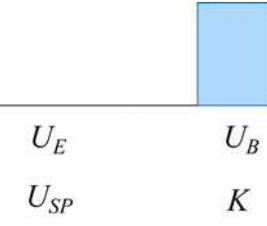
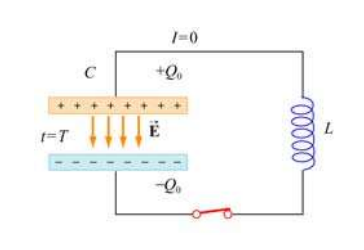
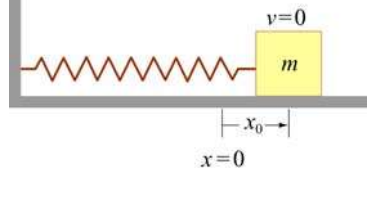
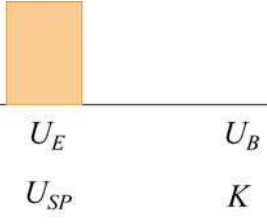
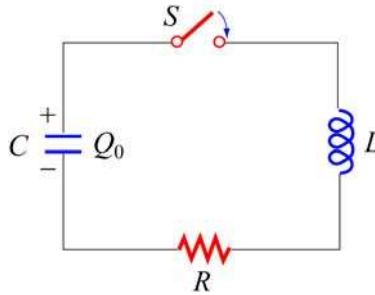

Figure 11.6.1 A series RLC circuit

The capacitor is initially charged to Q_0 . After the switch is closed current will begin to flow. However, unlike the LC circuit energy will be dissipated through the resistor. The rate at which energy is dissipated is

$$\frac{dU}{dt} = -I^2 R \quad (11.6.1)$$

where the negative sign on the right-hand side implies that the total energy is decreasing. After substituting Eq. (11.5.2) for the left-hand side of the above equation, we obtain the following differential equation:

$$\frac{Q}{C} \frac{dQ}{dt} + LI \frac{dI}{dt} = -I^2 R \quad (11.6.2)$$

Again, by our sign convention where current is equal to the rate of *decrease* of charge in the capacitor plates, $I = -dQ/dt$. Dividing both sides by I , the above equation can be rewritten as

$$\boxed{L \frac{d^2 Q}{dt^2} + R \frac{dQ}{dt} + \frac{Q}{C} = 0} \quad (11.6.3)$$

For small R (the underdamped case, see Appendix 1), one can readily verify that a solution to the above equation is

$$Q(t) = Q_0 e^{-\gamma t} \cos(\omega' t + \phi) \quad (11.6.4)$$

where

$$\gamma = \frac{R}{2L} \quad (11.6.5)$$

is the damping factor and

$$\omega' = \sqrt{\omega_0^2 - \gamma^2} \quad (11.6.6)$$

is the angular frequency of the damped oscillations. The constants Q_0 and ϕ are real quantities to be determined from the initial conditions. In the limit where the resistance vanishes, $R=0$, we recover the undamped, natural angular frequency $\omega_0 = 1/\sqrt{LC}$. There are three possible scenarios and the details are discussed in Appendix 1 (Section 11.8).

The mechanical analog of the series RLC circuit is the damped harmonic oscillator system. The equation of motion for this system is given by

$$m \frac{d^2x}{dt^2} + b \frac{dx}{dt} + kx = 0 \quad (11.6.7)$$

where the velocity-dependent term accounts for the non-conservative, dissipative force

$$F = -b \frac{dx}{dt} \quad (11.6.8)$$

with b being the damping coefficient. The correspondence between the RLC circuit and the mechanical system is summarized in Table 11.6.1. (Note that the sign of the current I depends on the physical situation under consideration.)

	RLC Circuit	Damped Harmonic Oscillator
Variable s	Q	x
Variable ds/dt	$\pm I$	v
Coefficient of s	$1/C$	k
Coefficient of ds/dt	R	b
Coefficient of d^2s/dt^2	L	m
Energy	$LI^2/2$	$mv^2/2$
	$Q^2/2C$	$kx^2/2$

Table 11.6.1 Correspondence between the RLC circuit and the mass-spring system

11.7 Summary

- Using Faraday's law of induction, the **mutual inductance** of two coils is given by

$$M_{12} = \frac{N_{12}\Phi_{12}}{I_1} = M_{21} = \frac{N_1\Phi_{21}}{I_2} = M$$

- The induced emf in coil 2 due to the change in current in coil 1 is given by

$$\varepsilon_2 = -M \frac{dI_1}{dt}$$

- The **self-inductance** of a coil with N turns is

$$L = \frac{N\Phi_B}{I}$$

where Φ_B is the magnetic flux through one turn of the coil.

- The **self-induced emf** responding to a change in current inside a coil current is

$$\varepsilon_L = -L \frac{dI}{dt}$$

- The inductance of a solenoid with N turns, cross sectional area A and length l is

$$L = \frac{\mu_0 N^2 A}{l}$$

- If a battery supplying an emf ε is connected to an inductor and a resistor in series at time $t = 0$, then the current in this **RL circuit** as a function of time is

$$I(t) = \frac{\varepsilon}{R} (1 - e^{-t/\tau})$$

where $\tau = L/R$ is the time constant of the circuit. If the battery is removed in the **RL circuit**, the current will decay as

$$I(t) = \left(\frac{\varepsilon}{R} \right) e^{-t/\tau}$$

- The **magnetic energy** stored in an inductor with current I passing through is

$$U_B = \frac{1}{2} LI^2$$

- The **magnetic energy density** at a point with magnetic field B is

$$u_B = \frac{B^2}{2\mu_0}$$

- The differential equation for an oscillating **LC circuit** is

$$\frac{d^2Q}{dt^2} + \omega_0^2 Q = 0$$

where $\omega_0 = \frac{1}{\sqrt{LC}}$ is the angular frequency of oscillation. The charge on the capacitor as a function of time is given by

$$Q(t) = Q_0 \cos(\omega_0 t + \phi)$$

and the current in the circuit is

$$I(t) = -\frac{dQ}{dt} = +\omega_0 Q_0 \sin(\omega_0 t + \phi)$$

- The total energy in an **LC circuit** is, using $I_0 = \omega_0 Q_0$,

$$U = U_E + U_B = \frac{Q_0^2}{2C} \cos^2 \omega_0 t + \frac{LI_0^2}{2} \sin^2 \omega_0 t = \frac{Q_0^2}{2C}$$

- The differential equation for an **RLC circuit** is

$$\frac{d^2Q}{dt^2} + 2\gamma \frac{dQ}{dt} + \omega_0^2 Q = 0$$

where $\omega_0 = \frac{1}{\sqrt{LC}}$ and $\gamma = R/2L$. In the underdamped case, the charge on the capacitor as a function of time is

$$Q(t) = Q_0 e^{-\gamma t} \cos(\omega' t + \phi)$$

where $\omega' = \sqrt{\omega_0^2 - \gamma^2}$.

11.8 Appendix 1: General Solutions for the *RLC* Series Circuit

In Section 11.6, we have shown that the *LRC* circuit is characterized by the following differential equation

$$L \frac{d^2 Q}{dt^2} + R \frac{dQ}{dt} + \frac{Q}{C} = 0 \quad (11.8.1)$$

whose solutions is given by

$$Q(t) = Q_0 e^{-\gamma t} \cos(\omega' t + \phi) \quad (11.8.2)$$

where

$$\gamma = \frac{R}{2L} \quad (11.8.3)$$

is the damping factor and

$$\omega' = \sqrt{\omega_0^2 - \gamma^2} \quad (11.8.4)$$

is the angular frequency of the damped oscillations. There are three possible scenarios, depending on the relative values of γ and ω_0 .

Case 1: Underdamping

When $\omega_0 > \gamma$, or equivalently, ω' is real and positive, the system is said to be underdamped. This is the case when the resistance is small. Charge oscillates (the cosine function) with an exponentially decaying amplitude $Q_0 e^{-\gamma t}$. However, the frequency of this damped oscillation is less than the undamped oscillation, $\omega' < \omega_0$. The qualitative behavior of the charge on the capacitor as a function of time is shown in Figure 11.8.1.

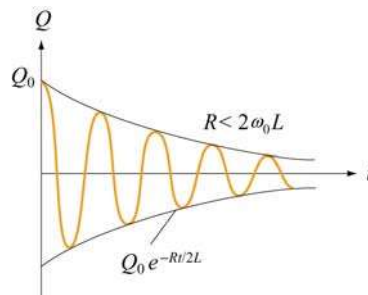

Figure 11.8.1 Underdamped oscillations

As an example, suppose the initial condition is $Q(t=0)=Q_0$. The phase is then $\phi=0$, and

$$Q(t) = Q_0 e^{-\gamma t} \cos \omega' t \quad (11.8.5)$$

The corresponding current is

$$I(t) = -\frac{dQ}{dt} = Q_0 \omega' e^{-\gamma t} [\sin \omega' t + (\gamma / \omega') \cos \omega' t] \quad (11.8.6)$$

For small R , the above expression may be approximated as

$$I(t) \approx \frac{Q_0}{\sqrt{LC}} e^{-\gamma t} \sin(\omega' t + \delta) \quad (11.8.7)$$

where

$$\delta = \tan^{-1} \left(\frac{\gamma}{\omega'} \right) \quad (11.8.8)$$

The derivation is left to the readers as an exercise.

Case 2: Overdamping

In the overdamped case, $\omega_0 < \gamma$, implying that ω' is imaginary. There is no oscillation in this case. By writing $\omega' = i\beta$, where $\beta = \sqrt{\gamma^2 - \omega_0^2}$, one may show that the most general solution can be written as

$$Q(t) = Q_1 e^{-(\gamma+\beta)t} + Q_2 e^{-(\gamma-\beta)t} \quad (11.8.9)$$

where the constants Q_1 and Q_2 can be determined from the initial conditions.

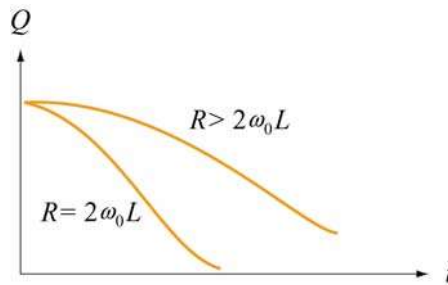

Figure 11.8.2 Overdamping and critical damping

Case 3: Critical damping

When the system is critically damped, $\omega_0 = \gamma$, $\omega' = 0$. Again there is no oscillation. The general solution is

$$Q(t) = (Q_1 + Q_2 t)e^{-\gamma t} \quad (11.8.10)$$

where Q_1 and Q_2 are constants which can be determined from the initial conditions. In this case one may show that the energy of the system decays most rapidly with time. The qualitative behavior of $Q(t)$ in overdamping and critical damping is depicted in Figure 11.8.2.

11.8.1 Quality Factor

When the resistance is small, the system is underdamped, and the charge oscillates with decaying amplitude $Q_0 e^{-\gamma t}$. The “quality” of this underdamped oscillation is measured by the so-called “quality factor,” Q (not to be confused with charge.) The larger the value of Q , the less the damping and the higher the quality. Mathematically, Q is defined as

$$Q = \omega' \left(\frac{\text{energy stored}}{\text{average power dissipated}} \right) = \omega' \frac{U}{|dU/dt|} \quad (11.8.11)$$

Using Eq. (11.8.2), the electric energy stored in the capacitor is

$$U_E = \frac{Q(t)^2}{2C} = \frac{Q_0^2}{2C} e^{-2\gamma t} \cos^2(\omega' t + \phi) \quad (11.8.12)$$

To obtain the magnetic energy, we approximate the current as

$$\begin{aligned} I(t) &= -\frac{dQ}{dt} = Q_0 \omega' e^{-\gamma t} \left[\sin(\omega' t + \phi) + \left(\frac{\gamma}{\omega'} \right) \cos(\omega' t + \phi) \right] \\ &\approx Q_0 \omega' e^{-\gamma t} \sin(\omega' t + \phi) \\ &\approx \frac{Q_0}{\sqrt{LC}} e^{-\gamma t} \sin(\omega' t + \phi) \end{aligned} \quad (11.8.13)$$

assuming that $\omega' \gg \gamma$ and $\omega'^2 \approx \omega_0^2 = 1/LC$. Thus, the magnetic energy stored in the inductor is given by

$$U_B = \frac{1}{2} L I^2 \approx \frac{L Q_0^2}{2} \omega'^2 e^{-2\gamma t} \sin^2(\omega' t + \phi) \approx \frac{Q_0^2}{2C} e^{-2\gamma t} \sin^2(\omega' t + \phi) \quad (11.8.14)$$

Adding up the two terms, the total energy of the system is

$$U = U_E + U_B \approx \frac{Q_0^2}{2C} e^{-2\gamma t} \cos^2(\omega' t + \phi) + \frac{Q_0^2}{2C} e^{-2\gamma t} \sin^2(\omega' t + \phi) = \left(\frac{Q_0^2}{2C} \right) e^{-2\gamma t} \quad (11.8.15)$$

Differentiating the expression with respect to t then yields the rate of change of energy:

$$\frac{dU}{dt} = -2\gamma \left(\frac{Q_0^2}{2C} e^{-2\gamma t} \right) = -2\gamma U \quad (11.8.16)$$

Thus, the quality factor becomes

$$Q = \omega' \frac{U}{|dU/dt|} = \frac{\omega'}{2\gamma} = \frac{\omega' L}{R} \quad (11.8.17)$$

As expected, the smaller the value of R , the greater the value of Q , and therefore the higher the quality of oscillation.

11.9 Appendix 2: Stresses Transmitted by Magnetic Fields

“...It appears therefore that the stress in the axis of a line of magnetic force is a tension, like that of a rope...”

J. C. Maxwell [1861].

In Chapter 9, we showed that the magnetic field due to an infinite sheet in the xy -plane carrying a surface current $\vec{\mathbf{K}} = K \hat{\mathbf{i}}$ is given by

$$\vec{\mathbf{B}} = \begin{cases} -\frac{\mu_0 K}{2} \hat{\mathbf{j}}, & z > 0 \\ \frac{\mu_0 K}{2} \hat{\mathbf{j}}, & z < 0 \end{cases} \quad (11.9.1)$$

Now consider two sheets separated by a distance d carrying surface currents in the opposite directions, as shown in Figure 11.9.1.

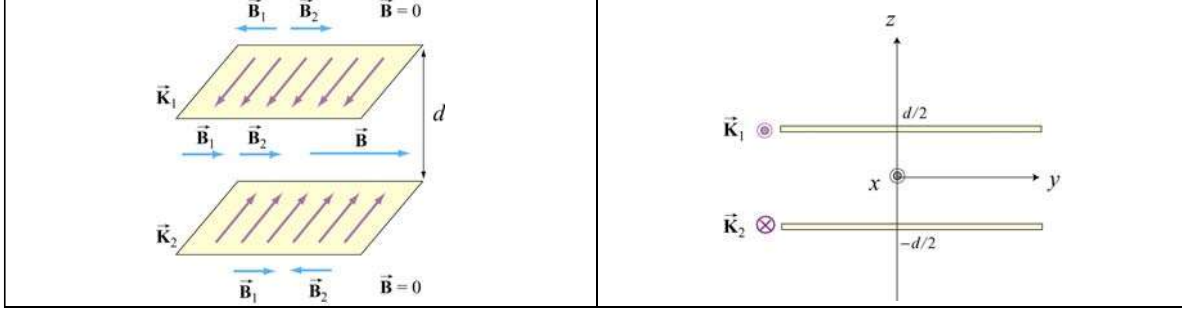

Figure 11.9.1 Magnetic field due to two sheets carrying surface current in the opposite directions

Using the superposition principle, we may show that the magnetic field is non-vanishing only in the region between the two sheets, and is given by

$$\vec{\mathbf{B}} = \mu_0 K \hat{\mathbf{j}}, \quad -d/2 < z < d/2 \quad (11.9.2)$$

Using Eq. (11.3.8), the magnetic energy stored in this system is

$$U_B = \frac{B^2}{2\mu_0} (Ad) = \frac{(\mu_0 K)^2}{2\mu_0} (Ad) = \frac{\mu_0}{2} K^2 (Ad) \quad (11.9.3)$$

where A is the area of the plate. The corresponding magnetic energy density is

$$u_B = \frac{U_B}{Ad} = \frac{\mu_0}{2} K^2 \quad (11.9.4)$$

Now consider a small current-carrying element $Id\vec{\mathbf{s}}_1 = (K\Delta y)\Delta x\hat{\mathbf{i}}$ on the upper plate (Recall that K has dimensions of current/length). The force experienced by this element due to the magnetic field of the lower sheet is

$$d\vec{\mathbf{F}}_{21} = Id\vec{\mathbf{s}}_1 \times \vec{\mathbf{B}}_2 = (K\Delta y \Delta x\hat{\mathbf{i}}) \times \left(\frac{\mu_0}{2} K \hat{\mathbf{j}} \right) = \frac{\mu_0}{2} K^2 (\Delta x \Delta y) \hat{\mathbf{k}} \quad (11.9.5)$$

The force points in the $+\hat{\mathbf{k}}$ direction and therefore is repulsive. This is expected since the currents flow in opposite directions. Since $d\vec{\mathbf{F}}_{21}$ is proportional to the area of the current element, we introduce force per unit area, $\vec{\mathbf{f}}_{21}$, and write

$$\vec{\mathbf{f}}_{21} = \vec{\mathbf{K}}_1 \times \vec{\mathbf{B}}_2 = \frac{\mu_0}{2} K^2 \hat{\mathbf{k}} = u_B \hat{\mathbf{k}} \quad (11.9.6)$$

using Eq. (11.9.4). The magnitude of the force per unit area, f_{21} , is exactly equal to the magnetic energy density u_B . Physically, f_{21} may be interpreted as the magnetic pressure

$$f_{21} = P = u_B = \frac{B^2}{2\mu_0} \quad (11.9.7)$$

The repulsive force experienced by the sheets is shown in Figure 11.9.2

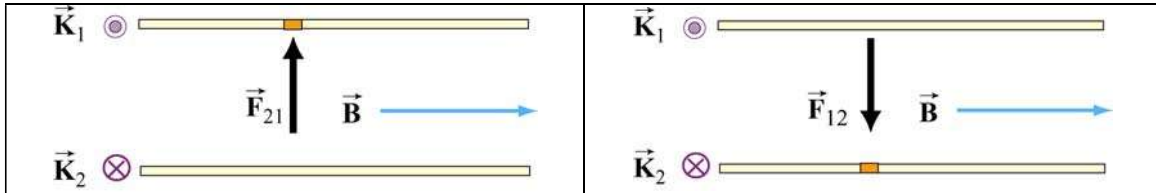

Figure 11.9.2 Magnetic pressure exerted on (a) the upper plate, and (b) the lower plate

Let's now consider a more general case of stress (pressure or tension) transmitted by fields. In Figure 11.9.3, we show an imaginary closed surface (an imaginary box) placed in a magnetic field. If we look at the face on the left side of this imaginary box, the field on that face is perpendicular to the outward normal to that face. Using the result illustrated in Figure 11.9.2, the field on that face transmits a pressure perpendicular to itself. In this case, this is a *push* to the *right*. Similarly, if we look at the face on the right side of this imaginary box, the field on that face is perpendicular to the outward normal to that face, the field on that face transmits a pressure perpendicular to itself. In this case, this is a *push* to the *left*.



Figure 11.9.3 An imaginary box in a magnetic field (blue vectors). The short vectors indicate the directions of stresses transmitted by the field, either pressures (on the left or right faces of the box) or tensions (on the top and bottom faces of the box).

If we want to know the total electromagnetic force transmitted to the interior of this imaginary box in the left-right direction, we add these two transmitted stresses. If the electric or magnetic field is homogeneous, this total electromagnetic force transmitted to

the interior of the box in the left-right direction is a push to the left and an equal but opposite push to the right, and the transmitted force adds up to zero.

In contrast, if the right side of this imaginary box is sitting inside a long vertical solenoid, for which the magnetic field is vertical and constant, and the left side is sitting outside of that solenoid, where the magnetic field is zero, then there is a net push to the left, and we say that the magnetic field exerts a outward *pressure* on the walls of the solenoid. We can deduce this by simply looking at the magnetic field topology. At sufficiently high magnetic field, such forces will cause the walls of a solenoid to explode outward.

Similarly, if we look at the top face of the imaginary box in Figure 11.9.3, the field on that face is parallel to the outward normal to that face, and one may show that the field on that face transmits a tension along itself across that face. In this case, this is an *upward pull*, just as if we had attached a string under tension to that face, pulling upward. (The actual determination of the direction of the force requires an advance treatment using the Maxwell stress tensor.) On the other hand, if we look at the bottom face of this imaginary box, the field on that face is anti-parallel to the outward normal to that face, and Faraday would again have said that the field on that face transmits a tension along itself. In this case, this is a *downward pull*, just as if we had attached a string to that face, pulling downward. Note that this is a *pull* parallel to the outward surface normal, whether the field is into the surface or out of the surface, since the pressures or tensions are proportional to the squares of the field magnitudes.

If we want to know the total electromagnetic force transmitted to the interior of this imaginary box in the up-down direction, we add these two transmitted stresses. If the magnetic field is homogeneous, this total electromagnetic force transmitted to the interior of the box in the up-down direction is a pull upward plus an equal and opposite pull downward, and adds to zero.

The magnitude of these pressures and tensions on the various faces of the imaginary surface in Figure 11.9.3 is given by $B^2 / 2\mu_0$, as shown in Eq. (11.9.7). Our discussion may be summarized as follows:

Pressures and Tensions Transmitted by Magnetic Fields

Electromagnetic fields are mediators of the interactions between material objects. The fields transmit stresses through space. A magnetic field transmits a tension along itself and a pressure perpendicular to itself. The magnitude of the tension or pressure transmitted by a magnetic field is given by

$$P = u_B = \frac{1}{2\mu_0} B^2$$

Animation 11.3: A Charged Particle in a Time-Varying Magnetic Field

As an example of the stresses transmitted by magnetic fields, consider a moving positive point charge at the origin in a rapidly changing time-dependent external field. This external field is uniform in space but varies in time according to the equation

$$\vec{\mathbf{B}} = -B_0 \sin^4\left(\frac{2\pi t}{T}\right) \hat{\mathbf{k}} \quad (11.9.8)$$

We assume that the variation of this field is so rapid that the charge moves only a negligible distance in one period T . Figure 11.9.4 shows two frames of an animation of the total magnetic field configuration for this situation. Figure 11.9.4(a) is at $t = 0$, when the vertical magnetic field is zero, and we see only the magnetic field of the moving charge (the charge is moving out of the page, so the field circulates clockwise). Frame 11.9.4(b) is at a quarter period later, when the vertically downward magnetic field is at a maximum. To the left of the charge, where the field of the charge is in the same direction as the external magnetic field (downward), the magnetic field is enhanced. To the right of the charge, where the field of the charge is opposite that of the external magnetic field, the magnetic field is reduced (and is zero at one point to the right of the charge).

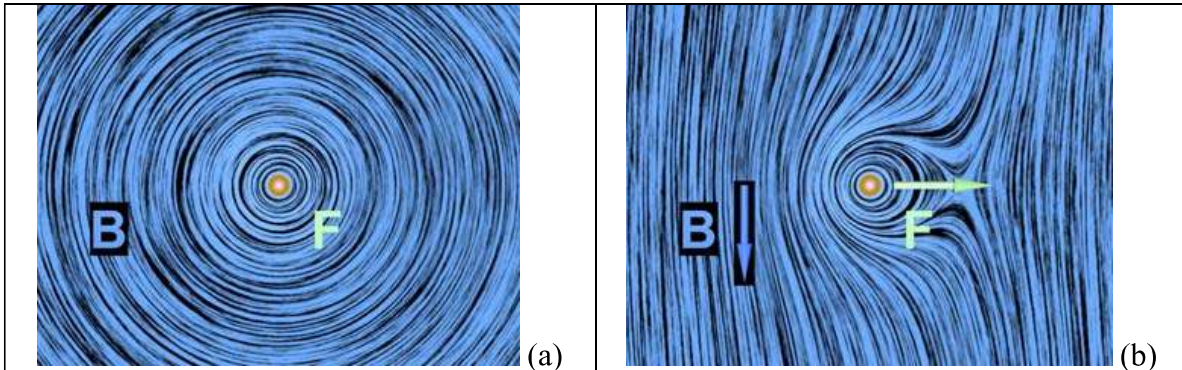

Figure 11.9.4 Two frames of an animation of the magnetic field around a positive charge moving out of the page in a time-changing magnetic field that points downward. The blue vector is the magnetic field and the white vector is the force on the point charge.

We interpret the field configuration in Figure 11.9.4(b) as indicating a net force to the right on the moving charge. This occurs because the pressure of the magnetic field is much higher on the left as compared to the right. Note that if the charge had been moving into the page instead of out of the page, the force would have been to the left, because the magnetic pressure would have been higher on the right. The animation of Figure 11.9.4 shows dramatically the inflow of energy into the neighborhood of the charge as the external magnetic field grows, with a resulting build-up of stress that transmits a sideways force to the moving positive charge.

We can estimate the magnitude of the force on the moving charge in Figure 11.9.4(b) as follows. At the time shown in Figure 11.9.4(b), the distance r_0 to the right of the charge at which the magnetic field of the charge is equal and opposite to the constant magnetic field is determined by

$$B_0 = \frac{\mu_0 q v}{4\pi r_0^2} \quad (11.9.9)$$

The surface area of a sphere of this radius is $A = 4\pi r_0^2 = \mu_0 q v / B_0$. Now according to Eq. (11.9.7) the pressure (force per unit area) and/or tension transmitted across the surface of this sphere surrounding the charge is of the order of $P = B^2 / 2\mu_0$. Since the magnetic field on the surface of the sphere is of the order B_0 , the total force transmitted by the field is of order

$$F = PA = \frac{B_0^2}{2\mu_0} (4\pi r_0^2) = \frac{B_0^2}{2\mu_0} \cdot \frac{\mu_0 q v}{B_0} \approx qvB_0 \quad (11.9.10)$$

Of course this net force is a combination of a pressure pushing to the right on the left side of the sphere and a tension pulling to the right on the right side of the sphere. The exact expression for the force on a charge moving in a magnetic field is

$$\vec{\mathbf{F}}_B = q \vec{\mathbf{v}} \times \vec{\mathbf{B}} \quad (11.9.11)$$

The rough estimate that we have just made demonstrates that the pressures and tensions transmitted across the surface of this sphere surrounding the moving charge are plausibly of the order $B^2 / 2\mu_0$. In addition, this argument gives us some insight in to why the magnetic force on a moving charge is transverse to the velocity of the charge and to the direction of the background field. This is because of the side of the charge on which the total magnetic pressure is the highest. It is this pressure that causes the deflection of the charge.

11.10 Problem-Solving Strategies

11.10.1 Calculating Self-Inductance

The self-inductance L of an inductor can be calculated using the following steps:

1. Assume a steady current I for the inductor, which may be a conducting loop, a solenoid, a toroid, or coaxial cables.
2. Choose an appropriate cross section S and compute the magnetic flux through S using

$$\Phi_B = \iint_S \vec{\mathbf{B}} \cdot d\vec{\mathbf{A}}$$

If the surface is bounded by N turns of wires, then the total magnetic flux through the surface would be $N\Phi_B$.

3. The inductance may be obtained as

$$L = \frac{N\Phi_B}{I}$$

11.10.2 Circuits containing inductors

Three types of single-loop circuits were examined in this chapter: RL , LC and RLC . To set up the differential equation for a circuit, we apply the Kirchhoff's loop and junction rules, as we did in Chapter 7 for the RC circuits. For circuits that contain inductors, the corresponding modified Kirchhoff's rule is schematically shown below.

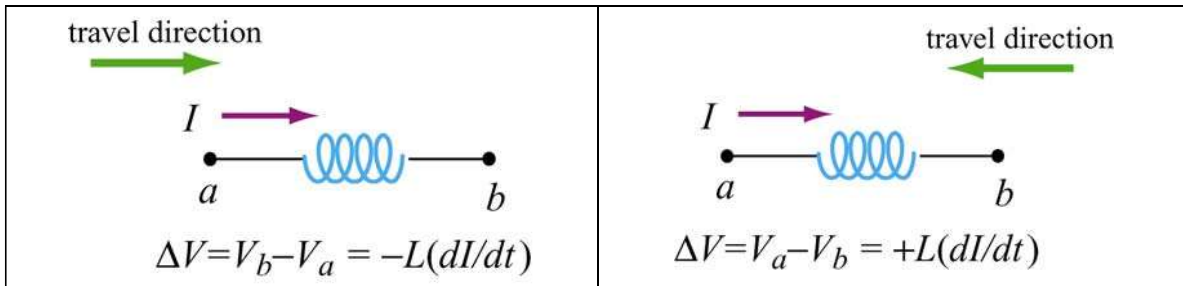

Note that the “potential difference” across the inductor is proportional to dI/dt , the rate of change of current. The situation simplifies if we are only interested in the long-term behavior of the circuit where the currents have reached their steady state and $dI/dt = 0$. In this limit, the inductor acts as a short circuit and can simply be replaced by an ideal wire.

11.11 Solved Problems

11.11.1 Energy stored in a toroid

A toroid consists of N turns and has a rectangular cross section, with inner radius a , outer radius b and height h (see Figure 11.2.3). Find the total magnetic energy stored in the toroid.

Solution:

In Example 11.3 we showed that the self-inductance of a toroid is

$$L = \frac{N\Phi_B}{I} = \frac{\mu_0 N^2 h}{2\pi} \ln\left(\frac{b}{a}\right)$$

Thus, the magnetic energy stored in the toroid is simply

$$U_B = \frac{1}{2} LI^2 = \frac{\mu_0 N^2 I^2 h}{4\pi} \ln\left(\frac{b}{a}\right) \quad (11.11.1)$$

Alternatively, the energy may be interpreted as being stored in the magnetic field. For a toroid, the magnetic field is (see Chapter 9)

$$B = \frac{\mu_0 NI}{2\pi r}$$

and the corresponding magnetic energy density is

$$u_B = \frac{1}{2} \frac{B^2}{\mu_0} = \frac{\mu_0 N^2 I^2}{8\pi^2 r^2} \quad (11.11.2)$$

The total energy stored in the magnetic field can be found by integrating over the volume. We choose the differential volume element to be a cylinder with radius r , width dr and height h , so that $dV = 2\pi r h dr$. This leads to

$$U_B = \int u_B dV = \int_a^b \left(\frac{\mu_0 N^2 I^2}{8\pi^2 r^2} \right) 2\pi r h dr = \frac{\mu_0 N^2 I^2 h}{4\pi} \ln\left(\frac{b}{a}\right) \quad (11.11.3)$$

Thus, both methods yield the same result.

11.11.2 Magnetic Energy Density

A wire of nonmagnetic material with radius R and length l carries a current I which is uniformly distributed over its cross-section. What is the magnetic energy inside the wire?

Solution:

Applying Ampere's law, the magnetic field at distance $r \leq R$ can be obtained as:

$$B(2\pi r) = \mu_0 J(\pi r^2) = \mu_0 \left(\frac{I}{\pi R^2} \right) (\pi r^2) \quad (11.11.4)$$

or

$$B = \frac{\mu_0 I r}{2\pi R^2} \quad (11.11.5)$$

Since the magnetic energy density (energy per unit volume) is given by

$$u_B = \frac{B^2}{2\mu_0} \quad (11.11.6)$$

the total magnetic energy stored in the system becomes

$$U_B = \int_0^R \frac{B^2}{2\mu_0} (2\pi r l dr) = \frac{\mu_0 I^2 l}{4\pi R^4} \int_0^R r^3 dr = \frac{\mu_0 I^2 l}{4\pi R^4} \left(\frac{R^4}{4} \right) = \frac{\mu_0 I^2 l}{16\pi} \quad (11.11.7)$$

11.11.3 Mutual Inductance

An infinite straight wire carrying current I is placed to the left of a rectangular loop of wire with width w and length l , as shown in the Figure 11.11.3. Determine the mutual inductance of the system.

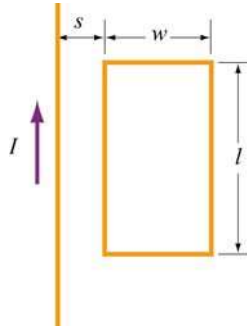

Figure 11.11.3 Rectangular loop placed near long straight current-carrying wire

Solution:

To calculate the mutual inductance M , we first need to know the magnetic flux through the rectangular loop. The magnetic field at a distance r away from the straight wire is $B = \mu_0 I / 2\pi r$, using Ampere's law. The total magnetic flux Φ_B through the loop can be obtained by summing over contributions from all differential area elements $dA = l dr$:

$$\Phi_B = \int d\Phi_B = \int \vec{\mathbf{B}} \cdot d\vec{\mathbf{A}} = \frac{\mu_0 I L}{2\pi} \int_s^{s+w} \frac{dr}{r} = \frac{\mu_0 I L}{2\pi} \ln\left(\frac{s+w}{s}\right) \quad (11.11.8)$$

Thus, the mutual inductance is

$$M = \frac{\Phi_B}{I} = \frac{\mu_0 l}{2\pi} \ln\left(\frac{s+w}{s}\right) \quad (11.11.9)$$

11.11.4 *RL* Circuit

Consider the circuit shown in Figure 11.11.4 below.

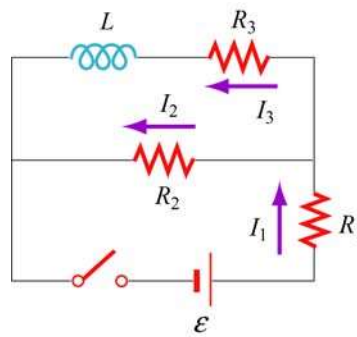

Figure 11.11.4 *RL* circuit

Determine the current through each resistor

- (a) immediately after the switch is closed.
- (b) a long time after the switch is closed.

Suppose the switch is reopened a long time after it's been closed. What is each current

- (c) immediately after it is opened?
- (d) after a long time?

Solution:

(a) Immediately after the switch is closed, the current through the inductor is zero because the self-induced emf prevents the current from rising abruptly. Therefore, $I_3 = 0$. Since $I_1 = I_2 + I_3$, we have $I_1 = I_2$

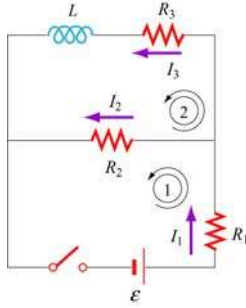

Figure 11.11.5

Applying Kirchhoff's rules to the first loop shown in Figure 11.11.5 yields

$$I_1 = I_2 = \frac{\varepsilon}{R_1 + R_2} \quad (11.11.10)$$

(b) After the switch has been closed for a long time, there is no induced emf in the inductor and the currents will be constant. Kirchhoff's loop rule gives

$$\varepsilon - I_1 R_1 - I_2 R_2 = 0 \quad (11.11.11)$$

for the first loop, and

$$I_2 R_2 - I_3 R_3 = 0 \quad (11.11.12)$$

for the second. Combining the two equations with the junction rule $I_1 = I_2 + I_3$, we obtain

$$\begin{aligned} I_1 &= \frac{(R_2 + R_3)\varepsilon}{R_1 R_2 + R_1 R_3 + R_2 R_3} \\ I_2 &= \frac{R_3 \varepsilon}{R_1 R_2 + R_1 R_3 + R_2 R_3} \\ I_3 &= \frac{R_2 \varepsilon}{R_1 R_2 + R_1 R_3 + R_2 R_3} \end{aligned} \quad (11.11.13)$$

(c) Immediately after the switch is opened, the current through R_1 is zero, i.e., $I_1 = 0$. This implies that $I_2 + I_3 = 0$. On the other hand, loop 2 now forms a decaying RL circuit and I_3 starts to decrease. Thus,

$$I_3 = -I_2 = \frac{R_2 \varepsilon}{R_1 R_2 + R_1 R_3 + R_2 R_3} \quad (11.11.14)$$

(d) A long time after the switch has been closed, all currents will be zero. That is, $I_1 = I_2 = I_3 = 0$.

11.11.5 *RL* Circuit

In the circuit shown in Figure 11.11.6, suppose the circuit is initially open. At time $t = 0$ it is thrown closed. What is the current in the inductor at a later time t ?

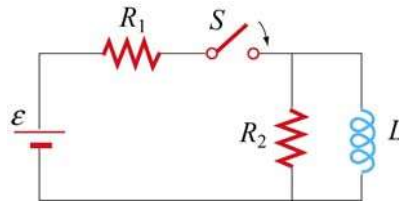

Figure 11.11.6 *RL* circuit

Solution:

Let the currents through R_1 , R_2 and L be I_1 , I_2 and I , respectively, as shown in Figure 11.11.7.

From Kirchhoff's junction rule, we have $I_1 = I_2 + I$. Similarly, applying Kirchhoff's loop rule to the left loop yields

$$\varepsilon - (I + I_2)R_1 - I_2R_2 = 0 \quad (11.11.15)$$

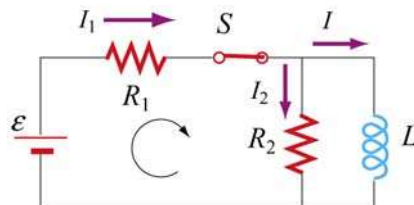

Figure 11.11.7

Similarly, for the outer loop, the modified Kirchhoff's loop rule gives

$$\varepsilon - (I + I_2)R_1 = L \frac{dI}{dt} \quad (11.11.16)$$

The two equations can be combined to yield

$$I_2R_2 = L \frac{dI}{dt} \quad \Rightarrow \quad I_2 = \frac{L}{R_2} \frac{dI}{dt} \quad (11.11.17)$$

Substituting into Eq. (11.11.15) the expression obtained above for I_2 , we have

$$\varepsilon - \left(I + \frac{L}{R_2} \frac{dI}{dt} \right) R_1 - L \frac{dI}{dt} = \varepsilon - IR_1 - \left(\frac{R_1 + R_2}{R_2} \right) L \frac{dI}{dt} = 0 \quad (11.11.18)$$

Dividing the equation by $(R_1 + R_2)/R_2$ leads to

$$\varepsilon' - IR' - L \frac{dI}{dt} = 0 \quad (11.11.19)$$

where

$$R' = \frac{R_1 R_2}{R_1 + R_2}, \quad \varepsilon' = \frac{R_2 \varepsilon}{R_1 + R_2} \quad (11.11.20)$$

The differential equation can be solved and the solution is given by

$$I(t) = \frac{\varepsilon'}{R'} (1 - e^{-R't/L}) \quad (11.11.21)$$

Since

$$\frac{\varepsilon'}{R'} = \frac{\varepsilon R_2 / (R_1 + R_2)}{R_1 R_2 / (R_1 + R_2)} = \frac{\varepsilon}{R_1} \quad (11.11.22)$$

the current through the inductor may be rewritten as

$$I(t) = \frac{\varepsilon}{R_1} (1 - e^{-R't/L}) = \frac{\varepsilon}{R_1} (1 - e^{-t/\tau}) \quad (11.11.23)$$

where $\tau = L/R'$ is the time constant.

11.11.6 LC Circuit

Consider the circuit shown in Figure 11.11.8. Suppose the switch which has been connected to point *a* for a long time is suddenly thrown to *b* at $t = 0$.

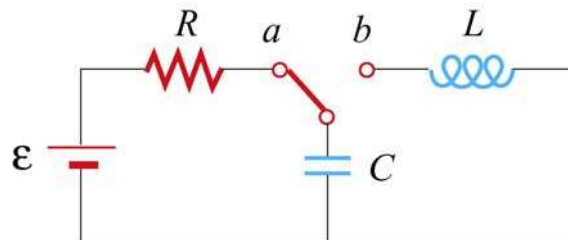

Figure 11.11.8 LC circuit

Find the following quantities:

- (a) the frequency of oscillation of the LC circuit.
- (b) the maximum charge that appears on the capacitor.
- (c) the maximum current in the inductor.
- (d) the total energy the circuit possesses at any time t .

Solution:

(a) The (angular) frequency of oscillation of the LC circuit is given by $\omega = 2\pi f = 1/\sqrt{LC}$. Therefore, the frequency is

$$f = \frac{1}{2\pi\sqrt{LC}} \quad (11.11.24)$$

(b) The maximum charge stored in the capacitor before the switch is thrown to b is

$$Q = C\varepsilon \quad (11.11.25)$$

(c) The energy stored in the capacitor before the switch is thrown is

$$U_E = \frac{1}{2}C\varepsilon^2 \quad (11.11.26)$$

On the other hand, the magnetic energy stored in the inductor is

$$U_B = \frac{1}{2}LI^2 \quad (11.11.27)$$

Thus, when the current is at its maximum, all the energy originally stored in the capacitor is now in the inductor:

$$\frac{1}{2}C\varepsilon^2 = \frac{1}{2}LI_0^2 \quad (11.11.28)$$

This implies a maximum current

$$I_0 = \varepsilon\sqrt{\frac{C}{L}} \quad (11.11.29)$$

(d) At any time, the total energy in the circuit would be equal to the initial energy that the capacitance stored, that is

$$U = U_E + U_B = \frac{1}{2} C \mathcal{E}^2 \quad (11.11.30)$$

11.12 Conceptual Questions

1. How would you shape a wire of fixed length to obtain the greatest and the smallest inductance?
2. If the wire of a tightly wound solenoid is unwound and made into another tightly wound solenoid with a diameter 3 times that of the original one, by what factor does the inductance change?
3. What analogies can you draw between an ideal solenoid and a parallel-plate capacitor?
4. In the RL circuit show in Figure 11.12.1, can the self-induced emf ever be greater than the emf supplied by the battery?

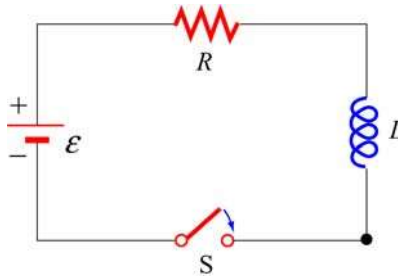

Figure 11.12.1

5. The magnetic energy density $u_B = B^2 / 2\mu_0$ may also be interpreted as the magnetic pressure. Using the magnetic pressure concept, explain the attractive (repulsive) force between two coils carrying currents in the same (opposite) direction.
6. Explain why the LC oscillation continues even after the capacitor has been completely discharged.
7. Explain physically why the time constant $\tau = L / R$ in an RL circuit is proportional to L and inversely proportional to R .

11.13 Additional Problems

11.13.1 Solenoid

A solenoid with a length of 30 cm, a radius of 1.0 cm and 500 turns carries a steady current $I = 2.0$ A .

- (a) What is the magnetic field at the center of the solenoid along the axis of symmetry?
- (b) Find the magnetic flux through the solenoid, assuming the magnetic field to be uniform.
- (c) What is the self-inductance of the solenoid?
- (d) What is the induced emf in the solenoid if the rate of change of current is $dI/dt = 100$ A/s ?

11.13.2 Self-Inductance

Suppose you try to wind a wire of length d and radius a into an inductor which has the shape of a cylinder with a circular cross section of radius r . The windings are tight without wires overlapping. Show that the self-inductance of this inductor is

$$L = \mu_0 \frac{rd}{4a}$$

11.13.3 Coupled Inductors

- (a) If two inductors with inductances L_1 and L_2 are connected in series, show that the equivalent inductance is

$$L_{\text{eq}} = L_1 + L_2 \pm 2M$$

where M is their mutual inductance. How is the sign chosen for M ? Under what condition can M be ignored?

- (b) If the inductors are instead connected in parallel, show that, if their mutual inductance can be ignored, the equivalent inductance is given by

$$\frac{1}{L_{\text{eq}}} = \frac{1}{L_1} + \frac{1}{L_2}$$

How would you take the effect of M into consideration?

11.13.4 RL Circuit

The LR circuit shown in Figure 11.13.1 contains a resistor R_1 and an inductance L in series with a battery of emf ε_0 . The switch S is initially closed. At $t = 0$, the switch S is opened, so that an additional very large resistance R_2 (with $R_2 \gg R_1$) is now in series with the other elements.

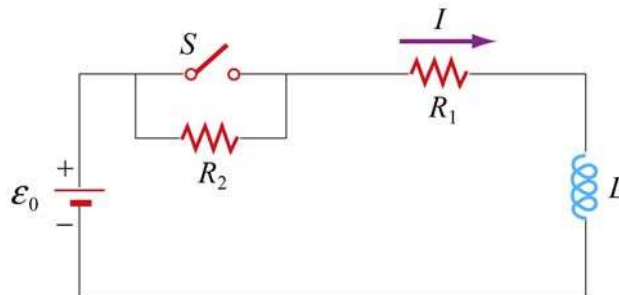

Figure 11.13.1 RL circuit

- (a) If the switch has been *closed* for a long time before $t = 0$, what is the steady current I_0 in the circuit?
- (b) While this current I_0 is flowing, at time $t = 0$, the switch S is opened. Write the differential equation for $I(t)$ that describes the behavior of the circuit at times $t \geq 0$. Solve this equation (by integration) for $I(t)$ under the approximation that $\varepsilon_0 = 0$. (Assume that the battery emf is negligible compared to the total emf around the circuit for times just after the switch is opened.) Express your answer in terms of the initial current I_0 , and R_1 , R_2 , and L .
- (c) Using your results from (b), find the value of the total emf around the circuit (which from Faraday's law is $-LdI/dt$) just after the switch is opened. Is your assumption in (b) that ε_0 could be ignored for times just after the switch is opened OK?
- (d) What is the magnitude of the potential drop across the resistor R_2 at times $t > 0$, just after the switch is opened? Express your answers in terms of ε_0 , R_1 , and R_2 . How does the potential drop across R_2 just after $t = 0$ compare to the battery emf ε_0 , if $R_2 = 100R_1$?

11.13.5 *RL* Circuit

In the circuit shown in Figure 11.13.2, $\mathcal{E} = 100 \text{ V}$, $R_1 = 10 \ \Omega$, $R_2 = 20 \ \Omega$, $R_3 = 30 \ \Omega$, and the inductance L in the right loop of the circuit is 2.0 H . The inductance in the left loop of the circuit is zero.

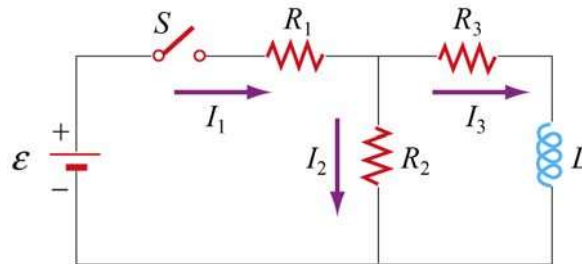

Figure 11.13.2 *RL* circuit

- Find I_1 and I_2 immediately after switch S is closed.
- Find I_1 and I_2 a long time later. What is the energy stored in the inductor a long time later?
- A long, long time later, switch S is opened again. Find I_1 and I_2 immediately after switch S is opened again.
- Find I_1 and I_2 a long time after switch S is opened. How much energy is dissipated in resistors R_2 and R_3 between the time immediately after switch S is opened again, and a long time after that?
- Give a crude estimate of what “a long time” is in this problem.

11.13.6 Inductance of a Solenoid With and Without Iron Core

- A long solenoid consists of N turns of wire, has length l , and cross-sectional area A . Show that the self-inductance can be written as $L = \mu_0 N^2 A / l$. Note that L increases as N^2 , and has dimensions of μ_0 times a length (as must always be true).
- A solenoid has a length of 126 cm and a diameter of 5.45 cm , with 1870 windings. What is its inductance if its interior is vacuum?
- If we now fill the interior with iron with an effective permeability constant $\kappa_m = 968$, what is its inductance?

(d) Suppose we connect this iron core inductor up in series with a battery and resistor, and that the total resistance in the circuit, including that of the battery and inductor, is 10Ω . How long does it take after the circuit is established for the current to reach 50% of its final value? [Ans: (b) 8.1 mH; (c) 7.88 H; (d) 0.55 s].

11.13.7 RLC Circuit

An RLC circuit with battery is set up as shown in Figure 11.13.3. There is no current flowing in the circuit until time $t = 0$, when the switch S_1 is closed.

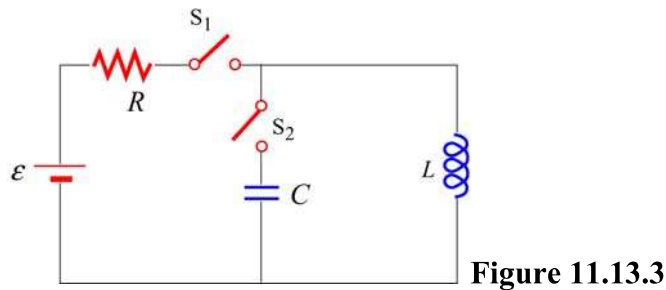

- (a) What is the current I in the circuit at a time $t > 0$ after the switch S_1 is closed?
- (b) What is the current I in the circuit a very long time ($t \gg L/R$) after the switch S_1 is closed?
- (c) How much energy is stored in the magnetic field of the solenoid a very long time ($t \gg L/R$) after the switch is closed?

For the next two questions, assume that a very long time ($t \gg L/R$) after the switch S_1 was closed, the voltage source is disconnected from the circuit by opening the switch S_1 and that the solenoid is simultaneously connected to a capacitor by closing the switch S_2 . Assume there is negligible resistance in this new circuit.

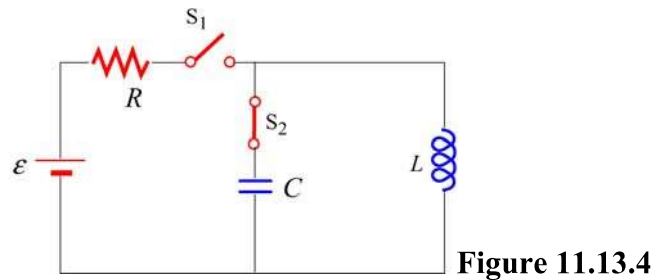

- (d) What is the maximum amount of charge that will appear on the capacitor, in terms of the quantities given?

(e) How long will it take for the capacitor to first reach a maximal charge after the switch S_2 has been closed?

11.13.8 Spinning Cylinder

Two concentric, conducting cylindrical shells are charged up by moving $+Q$ from the outer to the inner conductor, so that the inner conductor has a charge of $+Q$ spread uniformly over its area, and the outer conductor is left with $-Q$ uniformly distributed. The radius of the inner conductor is a ; the radius of the outer conductor is b ; the length of both is l ; and you may assume that $l \gg a, b$.

(a) What is the electric field for $r < a$, $a < r < b$, and $r > b$? Give both magnitude and direction.

(b) What is the total amount of energy in the electric field? (Hint: you may use a variety of ways to calculate this, such as using the energy density, or the capacitance, or the potential as a function of Q . It never hurts to check by doing it two different ways.)

(c) If the cylinders are now both spun counterclockwise (looking down the z axis) at the same angular velocity ω (so that the period of revolution is $T = 2\pi / \omega$), what is the total current (magnitude and sign) carried by each of the cylinders? Give your answer in terms of ω and the quantities from the first paragraph, and consider a current to be positive if it is in the same direction as ω .

(d) What is the magnetic field created when the cylinders are spinning at angular velocity ω ? You should give magnitude and direction of $\vec{\mathbf{B}}$ in each of the three regions: $r < a$, $a < r < b$, $r > b$. (Hint: it's easiest to do this by calculating $\vec{\mathbf{B}}$ from each cylinder independently and then getting the net magnetic field as the vector sum.)

(e) What is the total energy in the magnetic field when the cylinders are spinning at ω ?

11.13.9 Spinning Loop

A circular, conducting loop of radius a has resistance R and is spun about its diameter which lies along the y -axis, perpendicular to an external, uniform magnetic field $\vec{\mathbf{B}} = B \hat{\mathbf{k}}$. The angle between the normal to the loop and the magnetic field is θ , where $\theta = \omega t$. You may ignore the self-inductance of the loop.

(a) What is the magnetic flux through the loop as a function of time?

(b) What is the emf induced around the loop as a function of time?

- (c) What is the current flowing in the loop as a function of time?
- (d) At an instant that the normal to the loop aligns with the x -axis, the top of the loop lies on the $+z$ axis. At this moment is the current in this piece of loop in the $+\hat{\mathbf{j}}$ or $-\hat{\mathbf{j}}$ direction?
- (e) What is the magnitude of the new magnetic field B_{ind} (as a function of time) created at the center of the loop by the induced current?
- (f) Estimate the self-inductance L of the loop, using approximation that the magnetic field B_{ind} is uniform over the area of the loop and has the value calculated in part (e).
- (g) At what angular speed ω will the maximum induced magnetic field B_{ind} equal the external field B (therefore thoroughly contradicting the assumption of negligible self-inductance that went into the original calculation of B_{ind})? Express your answer in terms of R and L .

Chapter 12

Alternating-Current Circuits

12.1 AC Sources	1
12.2 Simple AC circuits.....	2
12.2.1 Purely Resistive load.....	2
12.2.2 Purely Inductive Load.....	4
12.2.3 Purely Capacitive Load.....	6
12.3 The <i>RLC</i> Series Circuit.....	8
12.3.1 Impedance.....	11
12.3.2 Resonance.....	12
12.4 Power in an AC circuit.....	13
12.4.1 Width of the Peak.....	15
12.5 Transformer	16
12.6 Parallel <i>RLC</i> Circuit.....	18
12.7 Summary	21
12.8 Problem-Solving Tips.....	23
12.9 Solved Problems	25
12.9.1 <i>RLC</i> Series Circuit	25
12.9.2 <i>RLC</i> Series Circuit	26
12.9.3 Resonance	27
12.9.4 <i>RL</i> High-Pass Filter.....	28
12.9.5 <i>RLC</i> Circuit.....	29
12.9.6 <i>RL</i> Filter	32
12.10 Conceptual Questions	34
12.11 Additional Problems	35
12.11.1 Reactance of a Capacitor and an Inductor	35
12.11.2 Driven <i>RLC</i> Circuit Near Resonance.....	35
12.11.3 <i>RC</i> Circuit	36
12.11.4 Black Box.....	36
12.11.5 Parallel <i>RL</i> Circuit.....	37
12.11.6 <i>LC</i> Circuit.....	38
12.11.7 Parallel <i>RC</i> Circuit	38
12.11.8 Power Dissipation	39
12.11.9 FM Antenna	39
12.11.10 Driven <i>RLC</i> Circuit.....	40

Alternating-Current Circuits

12.1 AC Sources

In Chapter 10 we learned that changing magnetic flux can induce an emf according to Faraday's law of induction. In particular, if a coil rotates in the presence of a magnetic field, the induced emf varies sinusoidally with time and leads to an alternating current (AC), and provides a source of AC power. The symbol for an AC voltage source is



An example of an AC source is

$$V(t) = V_0 \sin \omega t \quad (12.1.1)$$

where the maximum value V_0 is called the *amplitude*. The voltage varies between V_0 and $-V_0$ since a sine function varies between $+1$ and -1 . A graph of voltage as a function of time is shown in Figure 12.1.1.

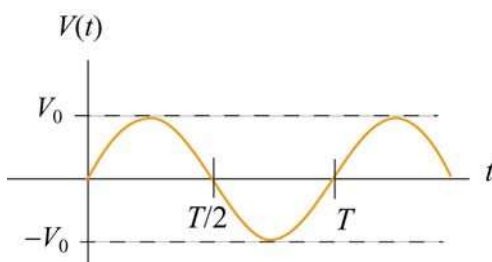

Figure 12.1.1 Sinusoidal voltage source

The sine function is periodic in time. This means that the value of the voltage at time t will be exactly the same at a later time $t' = t + T$ where T is the *period*. The *frequency*, f , defined as $f = 1/T$, has the unit of inverse seconds (s^{-1}), or hertz (Hz). The angular frequency is defined to be $\omega = 2\pi f$.

When a voltage source is connected to an RLC circuit, energy is provided to compensate the energy dissipation in the resistor, and the oscillation will no longer damp out. The oscillations of charge, current and potential difference are called driven or forced oscillations.

After an initial “transient time,” an AC current will flow in the circuit as a response to the driving voltage source. The current, written as

$$I(t) = I_0 \sin(\omega t - \phi) \quad (12.1.2)$$

will oscillate with the same frequency as the voltage source, with an amplitude I_0 and phase ϕ that depends on the driving frequency.

12.2 Simple AC circuits

Before examining the driven RLC circuit, let's first consider the simple cases where only one circuit element (a resistor, an inductor or a capacitor) is connected to a sinusoidal voltage source.

12.2.1 Purely Resistive load

Consider a purely resistive circuit with a resistor connected to an AC generator, as shown in Figure 12.2.1. (As we shall see, a purely resistive circuit corresponds to infinite capacitance $C = \infty$ and zero inductance $L = 0$.)

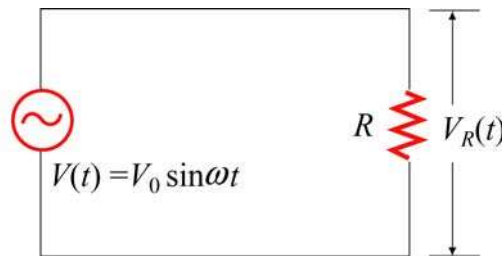

Figure 12.2.1 A purely resistive circuit

Applying Kirchhoff's loop rule yields

$$V(t) - V_R(t) = V(t) - I_R(t)R = 0 \quad (12.2.1)$$

where $V_R(t) = I_R(t)R$ is the instantaneous voltage drop across the resistor. The instantaneous current in the resistor is given by

$$I_R(t) = \frac{V_R(t)}{R} = \frac{V_{R0} \sin \omega t}{R} = I_{R0} \sin \omega t \quad (12.2.2)$$

where $V_{R0} = V_0$, and $I_{R0} = V_{R0}/R$ is the maximum current. Comparing Eq. (12.2.2) with Eq. (12.1.2), we find $\phi = 0$, which means that $I_R(t)$ and $V_R(t)$ are in phase with each other, meaning that they reach their maximum or minimum values at the same time. The time dependence of the current and the voltage across the resistor is depicted in Figure 12.2.2(a).

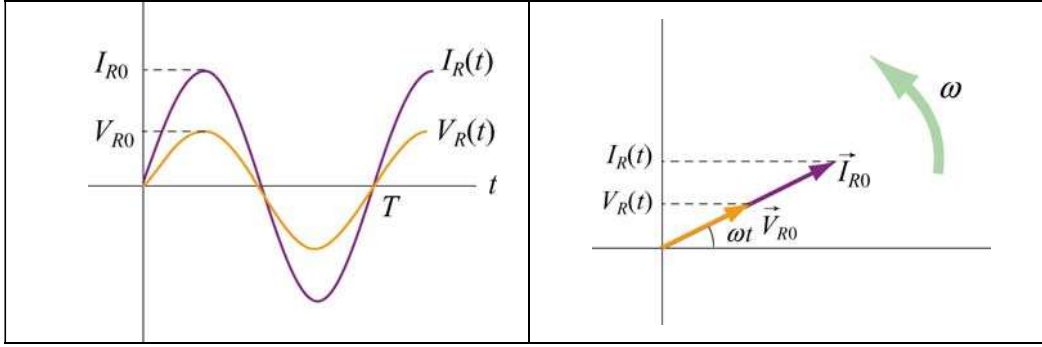

Figure 12.2.2 (a) Time dependence of $I_R(t)$ and $V_R(t)$ across the resistor. (b) Phasor diagram for the resistive circuit.

The behavior of $I_R(t)$ and $V_R(t)$ can also be represented with a phasor diagram, as shown in Figure 12.2.2(b). A phasor is a rotating vector having the following properties:

- (i) length: the length corresponds to the amplitude.
- (ii) angular speed: the vector rotates counterclockwise with an angular speed ω .
- (iii) projection: the projection of the vector along the vertical axis corresponds to the value of the alternating quantity at time t .

We shall denote a phasor with an arrow above it. The phasor \vec{V}_{R0} has a constant magnitude of V_{R0} . Its projection along the vertical direction is $V_{R0} \sin \omega t$, which is equal to $V_R(t)$, the voltage drop across the resistor at time t . A similar interpretation applies to \vec{I}_{R0} for the current passing through the resistor. From the phasor diagram, we readily see that both the current and the voltage are in phase with each other.

The average value of current over one period can be obtained as:

$$\langle I_R(t) \rangle = \frac{1}{T} \int_0^T I_R(t) dt = \frac{1}{T} \int_0^T I_{R0} \sin \omega t dt = \frac{I_{R0}}{T} \int_0^T \sin \frac{2\pi t}{T} dt = 0 \quad (12.2.3)$$

This average vanishes because

$$\langle \sin \omega t \rangle = \frac{1}{T} \int_0^T \sin \omega t dt = 0 \quad (12.2.4)$$

Similarly, one may find the following relations useful when averaging over one period:

$$\begin{aligned}
\langle \cos \omega t \rangle &= \frac{1}{T} \int_0^T \cos \omega t \, dt = 0 \\
\langle \sin \omega t \cos \omega t \rangle &= \frac{1}{T} \int_0^T \sin \omega t \cos \omega t \, dt = 0 \\
\langle \sin^2 \omega t \rangle &= \frac{1}{T} \int_0^T \sin^2 \omega t \, dt = \frac{1}{T} \int_0^T \sin^2 \left(\frac{2\pi t}{T} \right) dt = \frac{1}{2} \\
\langle \cos^2 \omega t \rangle &= \frac{1}{T} \int_0^T \cos^2 \omega t \, dt = \frac{1}{T} \int_0^T \cos^2 \left(\frac{2\pi t}{T} \right) dt = \frac{1}{2}
\end{aligned} \tag{12.2.5}$$

From the above, we see that the average of the square of the current is non-vanishing:

$$\langle I_R^2(t) \rangle = \frac{1}{T} \int_0^T I_R^2(t) dt = \frac{1}{T} \int_0^T I_{R0}^2 \sin^2 \omega t \, dt = I_{R0}^2 \frac{1}{T} \int_0^T \sin^2 \left(\frac{2\pi t}{T} \right) dt = \frac{1}{2} I_{R0}^2 \tag{12.2.6}$$

It is convenient to define the root-mean-square (rms) current as

$$I_{\text{rms}} = \sqrt{\langle I_R^2(t) \rangle} = \frac{I_{R0}}{\sqrt{2}} \tag{12.2.7}$$

In a similar manner, the rms voltage can be defined as

$$V_{\text{rms}} = \sqrt{\langle V_R^2(t) \rangle} = \frac{V_{R0}}{\sqrt{2}} \tag{12.2.8}$$

The rms voltage supplied to the domestic wall outlets in the United States is $V_{\text{rms}} = 120$ V at a frequency $f = 60$ Hz .

The power dissipated in the resistor is

$$P_R(t) = I_R(t) V_R(t) = I_R^2(t) R \tag{12.2.9}$$

from which the average over one period is obtained as:

$$\langle P_R(t) \rangle = \langle I_R^2(t) R \rangle = \frac{1}{2} I_{R0}^2 R = I_{\text{rms}}^2 R = I_{\text{rms}} V_{\text{rms}} = \frac{V_{\text{rms}}^2}{R} \tag{12.2.10}$$

12.2.2 Purely Inductive Load

Consider now a purely inductive circuit with an inductor connected to an AC generator, as shown in Figure 12.2.3.

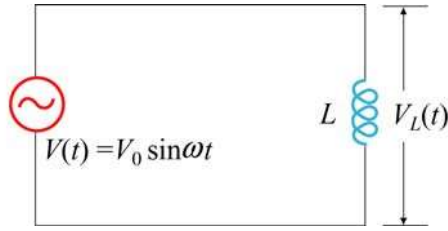

Figure 12.2.3 A purely inductive circuit

As we shall see below, a purely inductive circuit corresponds to infinite capacitance $C = \infty$ and zero resistance $R = 0$. Applying the modified Kirchhoff's rule for inductors, the circuit equation reads

$$V(t) - V_L(t) = V(t) - L \frac{dI_L}{dt} = 0 \quad (12.2.11)$$

which implies

$$\frac{dI_L}{dt} = \frac{V(t)}{L} = \frac{V_{L0}}{L} \sin \omega t \quad (12.2.12)$$

where $V_{L0} = V_0$. Integrating over the above equation, we find

$$I_L(t) = \int dI_L = \frac{V_{L0}}{L} \int \sin \omega t \, dt = -\left(\frac{V_{L0}}{\omega L}\right) \cos \omega t = \left(\frac{V_{L0}}{\omega L}\right) \sin\left(\omega t - \frac{\pi}{2}\right) \quad (12.2.13)$$

where we have used the trigonometric identity

$$-\cos \omega t = \sin\left(\omega t - \frac{\pi}{2}\right) \quad (12.2.14)$$

for rewriting the last expression. Comparing Eq. (12.2.14) with Eq. (12.1.2), we see that the amplitude of the current through the inductor is

$$I_{L0} = \frac{V_{L0}}{\omega L} = \frac{V_{L0}}{X_L} \quad (12.2.15)$$

where

$$X_L = \omega L \quad (12.2.16)$$

is called the *inductive reactance*. It has SI units of ohms (Ω), just like resistance. However, unlike resistance, X_L depends linearly on the angular frequency ω . Thus, the resistance to current flow increases with frequency. This is due to the fact that at higher

frequencies the current changes more rapidly than it does at lower frequencies. On the other hand, the inductive reactance vanishes as ω approaches zero.

By comparing Eq. (12.2.14) to Eq. (12.1.2), we also find the phase constant to be

$$\phi = +\frac{\pi}{2} \quad (12.2.17)$$

The current and voltage plots and the corresponding phasor diagram are shown in the Figure 12.2.4 below.

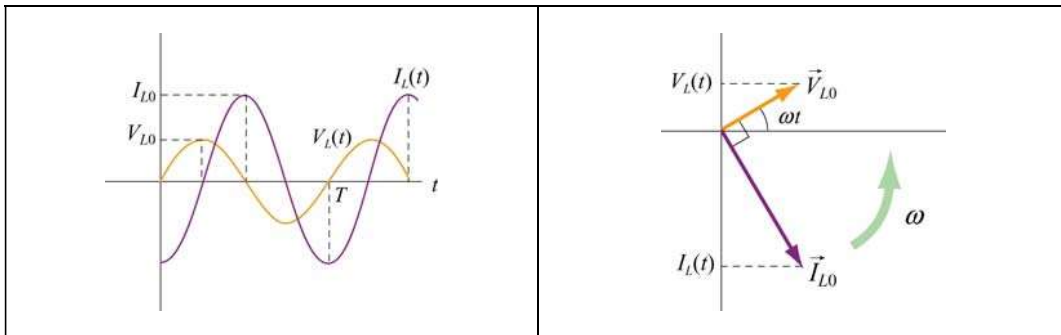

Figure 12.2.4 (a) Time dependence of $I_L(t)$ and $V_L(t)$ across the inductor. (b) Phasor diagram for the inductive circuit.

As can be seen from the figures, the current $I_L(t)$ is out of phase with $V_L(t)$ by $\phi = \pi / 2$; it reaches its maximum value after $V_L(t)$ does by one quarter of a cycle. Thus, we say that

The current lags voltage by $\pi / 2$ in a purely inductive circuit

12.2.3 Purely Capacitive Load

In the purely capacitive case, both resistance R and inductance L are zero. The circuit diagram is shown in Figure 12.2.5.

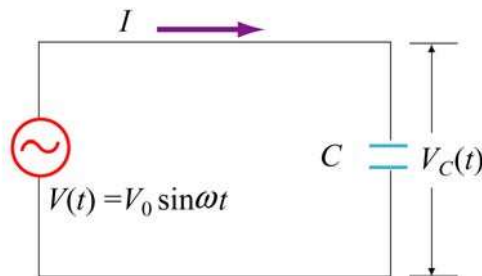

Figure 12.2.5 A purely capacitive circuit

Again, Kirchhoff's voltage rule implies

$$V(t) - V_C(t) = V(t) - \frac{Q(t)}{C} = 0 \quad (12.2.18)$$

which yields

$$Q(t) = CV(t) = CV_C(t) = CV_{C0} \sin \omega t \quad (12.2.19)$$

where $V_{C0} = V_0$. On the other hand, the current is

$$I_C(t) = +\frac{dQ}{dt} = \omega CV_{C0} \cos \omega t = \omega CV_{C0} \sin\left(\omega t + \frac{\pi}{2}\right) \quad (12.2.20)$$

where we have used the trigonometric identity

$$\cos \omega t = \sin\left(\omega t + \frac{\pi}{2}\right) \quad (12.2.21)$$

The above equation indicates that the maximum value of the current is

$$I_{C0} = \omega CV_{C0} = \frac{V_{C0}}{X_C} \quad (12.2.22)$$

where

$$X_C = \frac{1}{\omega C} \quad (12.2.23)$$

is called the *capacitance reactance*. It also has SI units of ohms and represents the effective resistance for a purely capacitive circuit. Note that X_C is inversely proportional to both C and ω , and diverges as ω approaches zero.

By comparing Eq. (12.2.21) to Eq. (12.1.2), the phase constant is given by

$$\phi = -\frac{\pi}{2} \quad (12.2.24)$$

The current and voltage plots and the corresponding phasor diagram are shown in the Figure 12.2.6 below.

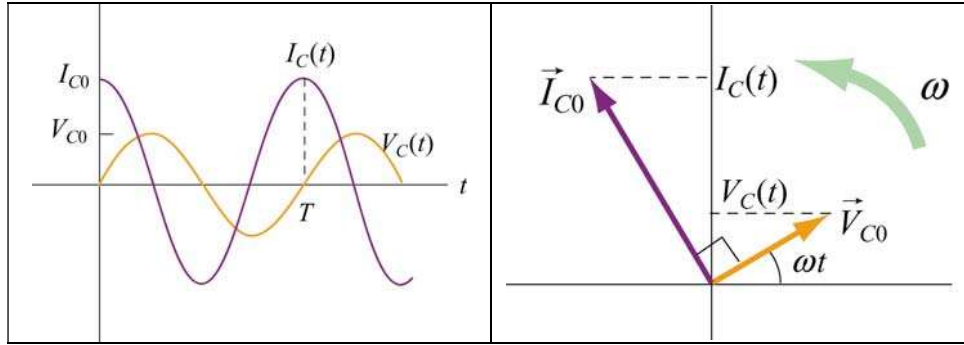

Figure 12.2.6 (a) Time dependence of $I_C(t)$ and $V_C(t)$ across the capacitor. (b) Phasor diagram for the capacitive circuit.

Notice that at $t = 0$, the voltage across the capacitor is zero while the current in the circuit is at a maximum. In fact, $I_C(t)$ reaches its maximum before $V_C(t)$ by one quarter of a cycle ($\phi = \pi/2$). Thus, we say that

The current leads the voltage by $\pi/2$ in a capacitive circuit

12.3 The RLC Series Circuit

Consider now the driven series RLC circuit shown in Figure 12.3.1.

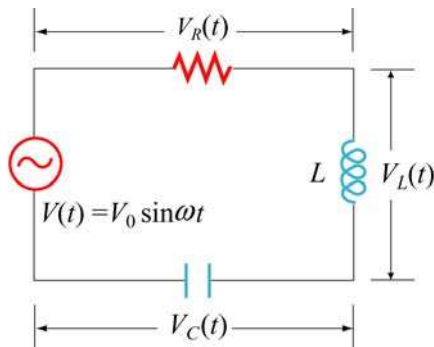

Figure 12.3.1 Driven series RLC Circuit

Applying Kirchhoff's loop rule, we obtain

$$V(t) - V_R(t) - V_L(t) - V_C(t) = V(t) - IR - L \frac{dI}{dt} - \frac{Q}{C} = 0 \quad (12.3.1)$$

which leads to the following differential equation:

$$L \frac{dI}{dt} + IR + \frac{Q}{C} = V_0 \sin \omega t \quad (12.3.2)$$

Assuming that the capacitor is initially uncharged so that $I = +dQ/dt$ is proportional to the *increase* of charge in the capacitor, the above equation can be rewritten as

$$\boxed{L \frac{d^2Q}{dt^2} + R \frac{dQ}{dt} + \frac{Q}{C} = V_0 \sin \omega t} \quad (12.3.3)$$

One possible solution to Eq. (12.3.3) is

$$Q(t) = Q_0 \cos(\omega t - \phi) \quad (12.3.4)$$

where the amplitude and the phase are, respectively,

$$\begin{aligned} Q_0 &= \frac{V_0 / L}{\sqrt{(R\omega / L)^2 + (\omega^2 - 1/LC)^2}} = \frac{V_0}{\omega \sqrt{R^2 + (\omega L - 1/\omega C)^2}} \\ &= \frac{V_0}{\omega \sqrt{R^2 + (X_L - X_C)^2}} \end{aligned} \quad (12.3.5)$$

and

$$\tan \phi = \frac{1}{R} \left(\omega L - \frac{1}{\omega C} \right) = \frac{X_L - X_C}{R} \quad (12.3.6)$$

The corresponding current is

$$I(t) = + \frac{dQ}{dt} = I_0 \sin(\omega t - \phi) \quad (12.3.7)$$

with an amplitude

$$I_0 = -Q_0 \omega = - \frac{V_0}{\sqrt{R^2 + (X_L - X_C)^2}} \quad (12.3.8)$$

Notice that the current has the same amplitude and phase at all points in the series *RLC* circuit. On the other hand, the instantaneous voltage across each of the three circuit elements *R*, *L* and *C* has a different amplitude and phase relationship with the current, as can be seen from the phasor diagrams shown in Figure 12.3.2.

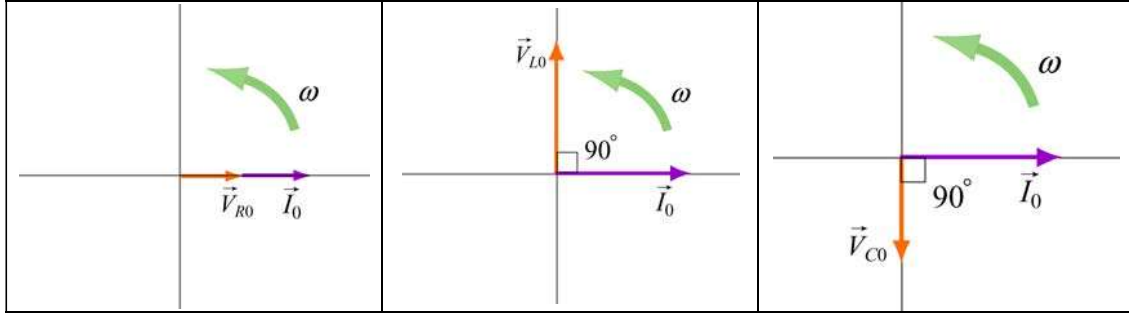

Figure 12.3.2 Phasor diagrams for the relationships between current and voltage in (a) the resistor, (b) the inductor, and (c) the capacitor, of a series RLC circuit.

From Figure 12.3.2, the instantaneous voltages can be obtained as:

$$\begin{aligned}
 V_R(t) &= I_0 R \sin \omega t = V_{R0} \sin \omega t \\
 V_L(t) &= I_0 X_L \sin \left(\omega t + \frac{\pi}{2} \right) = V_{L0} \cos \omega t \\
 V_C(t) &= I_0 X_C \sin \left(\omega t - \frac{\pi}{2} \right) = -V_{C0} \cos \omega t
 \end{aligned} \tag{12.3.9}$$

where

$$V_{R0} = I_0 R, \quad V_{L0} = I_0 X_L, \quad V_{C0} = I_0 X_C \tag{12.3.10}$$

are the amplitudes of the voltages across the circuit elements. The sum of all three voltages is equal to the instantaneous voltage supplied by the AC source:

$$V(t) = V_R(t) + V_L(t) + V_C(t) \tag{12.3.11}$$

Using the phasor representation, the above expression can also be written as

$$\vec{V}_0 = \vec{V}_{R0} + \vec{V}_{L0} + \vec{V}_{C0} \tag{12.3.12}$$

as shown in Figure 12.3.3 (a). Again we see that current phasor \vec{I}_0 leads the capacitive voltage phasor \vec{V}_{C0} by $\pi/2$ but lags the inductive voltage phasor \vec{V}_{L0} by $\pi/2$. The three voltage phasors rotate counterclockwise as time passes, with their relative positions fixed.

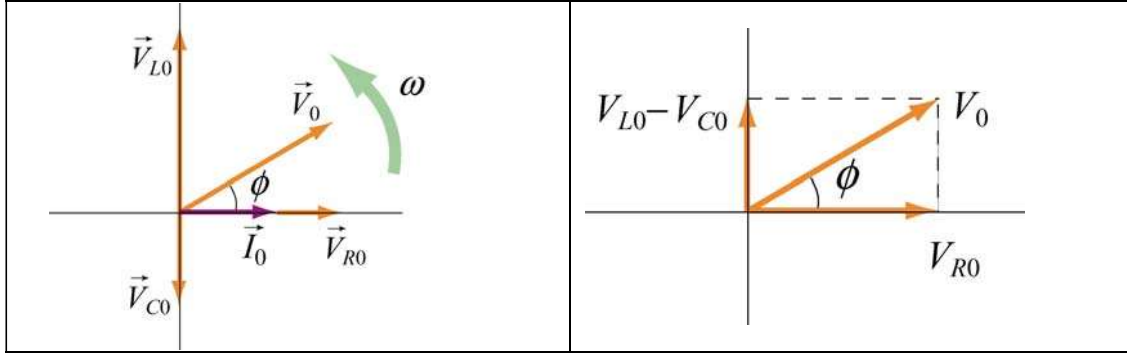

Figure 12.3.3 (a) Phasor diagram for the series RLC circuit. (b) voltage relationship

The relationship between different voltage amplitudes is depicted in Figure 12.3.3(b). From the Figure, we see that

$$\begin{aligned}
 V_0 = |\vec{V}_0| &= |\vec{V}_{R0} + \vec{V}_{L0} + \vec{V}_{C0}| = \sqrt{V_{R0}^2 + (V_{L0} - V_{C0})^2} \\
 &= \sqrt{(I_0 R)^2 + (I_0 X_L - I_0 X_C)^2} \\
 &= I_0 \sqrt{R^2 + (X_L - X_C)^2}
 \end{aligned} \tag{12.3.13}$$

which leads to the same expression for I_0 as that obtained in Eq. (12.3.7).

It is crucial to note that the maximum amplitude of the AC voltage source V_0 is not equal to the sum of the maximum voltage amplitudes across the three circuit elements:

$$V_0 \neq V_{R0} + V_{L0} + V_{C0} \tag{12.3.14}$$

This is due to the fact that the voltages are not in phase with one another, and they reach their maxima at different times.

12.3.1 Impedance

We have already seen that the inductive reactance $X_L = \omega L$ and capacitance reactance $X_C = 1/\omega C$ play the role of an effective resistance in the purely inductive and capacitive circuits, respectively. In the series RLC circuit, the effective resistance is the *impedance*, defined as

$$Z = \sqrt{R^2 + (X_L - X_C)^2} \tag{12.3.15}$$

The relationship between Z , X_L and X_C can be represented by the diagram shown in Figure 12.3.4:

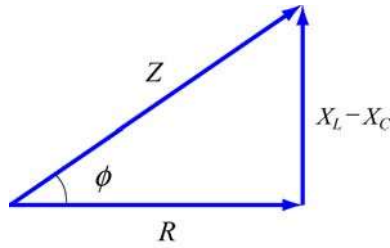

Figure 12.3.4 Diagrammatic representation of the relationship between Z , X_L and X_C .

The impedance also has SI units of ohms. In terms of Z , the current may be rewritten as

$$I(t) = \frac{V_0}{Z} \sin(\omega t - \phi) \quad (12.3.16)$$

Notice that the impedance Z also depends on the angular frequency ω , as do X_L and X_C .

Using Eq. (12.3.6) for the phase ϕ and Eq. (12.3.15) for Z , we may readily recover the limits for simple circuit (with only one element). A summary is provided in Table 12.1 below:

Simple Circuit	R	L	C	$X_L = \omega L$	$X_C = \frac{1}{\omega C}$	$\phi = \tan^{-1}\left(\frac{X_L - X_C}{R}\right)$	$Z = \sqrt{R^2 + (X_L - X_C)^2}$
purely resistive	R	0	∞	0	0	0	R
purely inductive	0	L	∞	X_L	0	$\pi/2$	X_L
purely capacitive	0	0	C	0	X_C	$-\pi/2$	X_C

Table 12.1 Simple-circuit limits of the series RLC circuit

12.3.2 Resonance

Eq. (12.3.15) indicates that the amplitude of the current $I_0 = V_0 / Z$ reaches a maximum when Z is at a minimum. This occurs when $X_L = X_C$, or $\omega L = 1 / \omega C$, leading to

$$\omega_0 = \frac{1}{\sqrt{LC}} \quad (12.3.17)$$

The phenomenon at which I_0 reaches a maximum is called a resonance, and the frequency ω_0 is called the resonant frequency. At resonance, the impedance becomes $Z = R$, the amplitude of the current is

$$I_0 = \frac{V_0}{R} \quad (12.3.18)$$

and the phase is

$$\phi = 0 \quad (12.3.19)$$

as can be seen from Eq. (12.3.5). The qualitative behavior is illustrated in Figure 12.3.5.

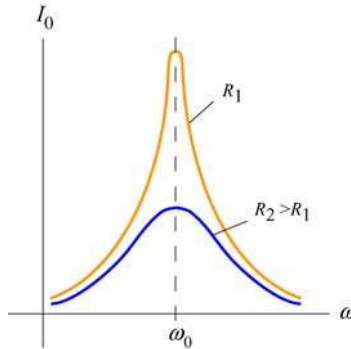

Figure 12.3.5 The amplitude of the current as a function of ω in the driven *RLC* circuit.

12.4 Power in an AC circuit

In the series *RLC* circuit, the instantaneous power delivered by the AC generator is given by

$$\begin{aligned} P(t) &= I(t)V(t) = \frac{V_0}{Z} \sin(\omega t - \phi) \cdot V_0 \sin \omega t = \frac{V_0^2}{Z} \sin(\omega t - \phi) \sin \omega t \\ &= \frac{V_0^2}{Z} (\sin^2 \omega t \cos \phi - \sin \omega t \cos \omega t \sin \phi) \end{aligned} \quad (12.4.1)$$

where we have used the trigonometric identity

$$\sin(\omega t - \phi) = \sin \omega t \cos \phi - \cos \omega t \sin \phi \quad (12.4.2)$$

The time average of the power is

$$\begin{aligned}
\langle P(t) \rangle &= \frac{1}{T} \int_0^T \frac{V_0^2}{Z} \sin^2 \omega t \cos \phi \, dt - \frac{1}{T} \int_0^T \frac{V_0^2}{Z} \sin \omega t \cos \omega t \sin \phi \, dt \\
&= \frac{V_0^2}{Z} \cos \phi \langle \sin^2 \omega t \rangle - \frac{V_0^2}{Z} \sin \phi \langle \sin \omega t \cos \omega t \rangle \\
&= \frac{1}{2} \frac{V_0^2}{Z} \cos \phi
\end{aligned}
\tag{12.4.3}$$

where Eqs. (12.2.5) and (12.2.7) have been used. In terms of the rms quantities, the average power can be rewritten as

$$\langle P(t) \rangle = \frac{1}{2} \frac{V_0^2}{Z} \cos \phi = \frac{V_{\text{rms}}^2}{Z} \cos \phi = I_{\text{rms}} V_{\text{rms}} \cos \phi
\tag{12.4.4}$$

The quantity $\cos \phi$ is called the *power factor*. From Figure 12.3.4, one can readily show that

$$\cos \phi = \frac{R}{Z}
\tag{12.4.5}$$

Thus, we may rewrite $\langle P(t) \rangle$ as

$$\langle P(t) \rangle = I_{\text{rms}} V_{\text{rms}} \left(\frac{R}{Z} \right) = I_{\text{rms}} \left(\frac{V_{\text{rms}}}{Z} \right) R = I_{\text{rms}}^2 R
\tag{12.4.6}$$

In Figure 12.4.1, we plot the average power as a function of the driving angular frequency ω .

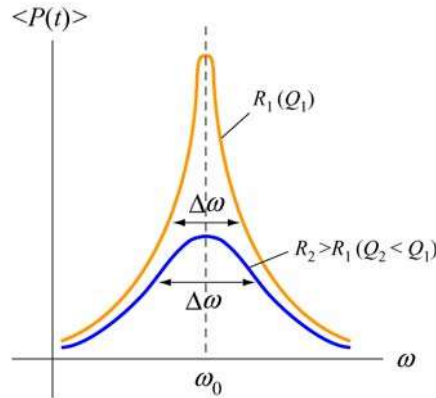

Figure 12.4.1 Average power as a function of frequency in a driven series *RLC* circuit.

We see that $\langle P(t) \rangle$ attains the maximum when $\cos \phi = 1$, or $Z = R$, which is the resonance condition. At resonance, we have

$$\langle P \rangle_{\max} = I_{\text{rms}} V_{\text{rms}} = \frac{V_{\text{rms}}^2}{R} \quad (12.4.7)$$

12.4.1 Width of the Peak

The peak has a line width. One way to characterize the width is to define $\Delta\omega = \omega_+ - \omega_-$, where ω_{\pm} are the values of the driving angular frequency such that the power is equal to half its maximum power at resonance. This is called *full width at half maximum*, as illustrated in Figure 12.4.2. The width $\Delta\omega$ increases with resistance R .

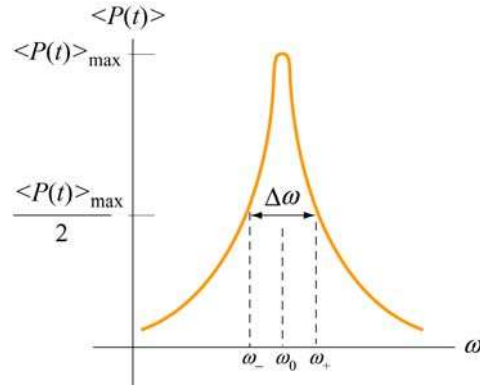

Figure 12.4.2 Width of the peak

To find $\Delta\omega$, it is instructive to first rewrite the average power $\langle P(t) \rangle$ as

$$\langle P(t) \rangle = \frac{1}{2} \frac{V_0^2 R}{R^2 + (\omega L - 1/\omega C)^2} = \frac{1}{2} \frac{V_0^2 R \omega^2}{\omega^2 R^2 + L^2 (\omega^2 - \omega_0^2)^2} \quad (12.4.8)$$

with $\langle P(t) \rangle_{\max} = V_0^2 / 2R$. The condition for finding ω_{\pm} is

$$\frac{1}{2} \langle P(t) \rangle_{\max} = \langle P(t) \rangle \Big|_{\omega_{\pm}} \Rightarrow \frac{V_0^2}{4R} = \frac{1}{2} \frac{V_0^2 R \omega^2}{\omega^2 R^2 + L^2 (\omega^2 - \omega_0^2)^2} \Big|_{\omega_{\pm}} \quad (12.4.9)$$

which gives

$$(\omega^2 - \omega_0^2)^2 = \left(\frac{R\omega}{L} \right)^2 \quad (12.4.10)$$

Taking square roots yields two solutions, which we analyze separately.

case 1: Taking the positive root leads to

$$\omega_+^2 - \omega_0^2 = + \frac{R\omega_+}{L} \quad (12.4.11)$$

Solving the quadratic equation, the solution with positive root is

$$\omega_+ = \frac{R}{2L} + \sqrt{\left(\frac{R}{4L}\right)^2 + \omega_0^2} \quad (12.4.12)$$

Case 2: Taking the negative root of Eq. (12.4.10) gives

$$\omega_-^2 - \omega_0^2 = - \frac{R\omega_-}{L} \quad (12.4.13)$$

The solution to this quadratic equation with positive root is

$$\omega_- = -\frac{R}{2L} + \sqrt{\left(\frac{R}{4L}\right)^2 + \omega_0^2} \quad (12.4.14)$$

The width at half maximum is then

$$\Delta\omega = \omega_+ - \omega_- = \frac{R}{L} \quad (12.4.15)$$

Once the width $\Delta\omega$ is known, the quality factor Q (not to be confused with charge) can be obtained as

$$\boxed{Q = \frac{\omega_0}{\Delta\omega} = \frac{\omega_0 L}{R}} \quad (12.4.16)$$

Comparing the above equation with Eq. (11.8.17), we see that both expressions agree with each other in the limit where the resistance is small, and $\omega' = \sqrt{\omega_0^2 - (R/2L)^2} \approx \omega_0$.

12.5 Transformer

A transformer is a device used to increase or decrease the AC voltage in a circuit. A typical device consists of two coils of wire, a primary and a secondary, wound around an iron core, as illustrated in Figure 12.5.1. The primary coil, with N_1 turns, is connected to alternating voltage source $V_1(t)$. The secondary coil has N_2 turns and is connected to a “load resistance” R_2 . The way transformers operate is based on the principle that an

alternating current in the primary coil will induce an alternating emf on the secondary coil due to their mutual inductance.

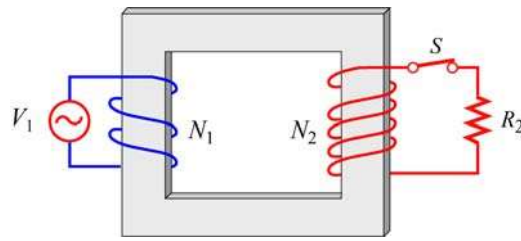

Figure 12.5.1 A transformer

In the primary circuit, neglecting the small resistance in the coil, Faraday’s law of induction implies

$$V_1 = -N_1 \frac{d\Phi_B}{dt} \quad (12.5.1)$$

where Φ_B is the magnetic flux through one turn of the primary coil. The iron core, which extends from the primary to the secondary coils, serves to increase the magnetic field produced by the current in the primary coil and ensure that nearly all the magnetic flux through the primary coil also passes through each turn of the secondary coil. Thus, the voltage (or induced emf) across the secondary coil is

$$V_2 = -N_2 \frac{d\Phi_B}{dt} \quad (12.5.2)$$

In the case of an ideal transformer, power loss due to Joule heating can be ignored, so that the power supplied by the primary coil is completely transferred to the secondary coil:

$$I_1 V_1 = I_2 V_2 \quad (12.5.3)$$

In addition, no magnetic flux leaks out from the iron core, and the flux Φ_B through each turn is the same in both the primary and the secondary coils. Combining the two expressions, we are lead to the transformer equation:

$$\boxed{\frac{V_2}{V_1} = \frac{N_2}{N_1}} \quad (12.5.4)$$

By combining the two equations above, the transformation of currents in the two coils may be obtained as:

$$I_1 = \left(\frac{V_2}{V_1} \right) I_2 = \left(\frac{N_2}{N_1} \right) I_2 \quad (12.5.5)$$

Thus, we see that the ratio of the output voltage to the input voltage is determined by the *turn ratio* N_2/N_1 . If $N_2 > N_1$, then $V_2 > V_1$, which means that the output voltage in the second coil is greater than the input voltage in the primary coil. A transformer with $N_2 > N_1$ is called a *step-up* transformer. On the other hand, if $N_2 < N_1$, then $V_2 < V_1$, and the output voltage is smaller than the input. A transformer with $N_2 < N_1$ is called a *step-down* transformer.

12.6 Parallel RLC Circuit

Consider the parallel RLC circuit illustrated in Figure 12.6.1. The AC voltage source is $V(t) = V_0 \sin \omega t$.

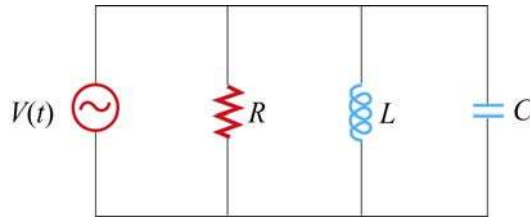

Figure 12.6.1 Parallel RLC circuit.

Unlike the series RLC circuit, the instantaneous voltages across all three circuit elements R , L , and C are the same, and each voltage is in phase with the current through the resistor. However, the currents through each element will be different.

In analyzing this circuit, we make use of the results discussed in Sections 12.2 – 12.4. The current in the resistor is

$$I_R(t) = \frac{V(t)}{R} = \frac{V_0}{R} \sin \omega t = I_{R0} \sin \omega t \quad (12.6.1)$$

where $I_{R0} = V_0/R$. The voltage across the inductor is

$$V_L(t) = V(t) = V_0 \sin \omega t = L \frac{dI_L}{dt} \quad (12.6.2)$$

which gives

$$I_L(t) = \int_0^t \frac{V_0}{L} \sin \omega t' dt' = -\frac{V_0}{\omega L} \cos \omega t = \frac{V_0}{X_L} \sin \left(\omega t - \frac{\pi}{2} \right) = I_{L0} \sin \left(\omega t - \frac{\pi}{2} \right) \quad (12.6.3)$$

where $I_{L0} = V_0 / X_L$ and $X_L = \omega L$ is the inductive reactance.

Similarly, the voltage across the capacitor is $V_C(t) = V_0 \sin \omega t = Q(t) / C$, which implies

$$I_C(t) = \frac{dQ}{dt} = \omega C V_0 \cos \omega t = \frac{V_0}{X_C} \sin\left(\omega t + \frac{\pi}{2}\right) = I_{C0} \sin\left(\omega t + \frac{\pi}{2}\right) \quad (12.6.4)$$

where $I_{C0} = V_0 / X_C$ and $X_C = 1 / \omega C$ is the capacitive reactance.

Using Kirchoff's junction rule, the total current in the circuit is simply the sum of all three currents.

$$\begin{aligned} I(t) &= I_R(t) + I_L(t) + I_C(t) \\ &= I_{R0} \sin \omega t + I_{L0} \sin\left(\omega t - \frac{\pi}{2}\right) + I_{C0} \sin\left(\omega t + \frac{\pi}{2}\right) \end{aligned} \quad (12.6.5)$$

The currents can be represented with the phasor diagram shown in Figure 12.6.2.

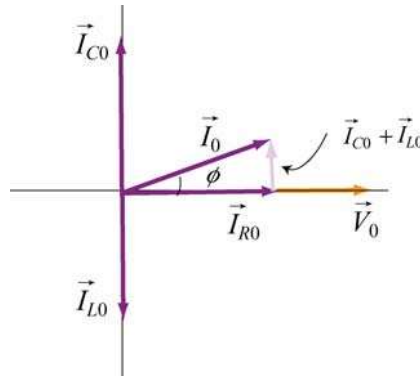

Figure 12.6.2 Phasor diagram for the parallel RLC circuit

From the phasor diagram, we see that

$$\vec{I}_0 = \vec{I}_{R0} + \vec{I}_{L0} + \vec{I}_{C0} \quad (12.6.6)$$

and the maximum amplitude of the total current, I_0 , can be obtained as

$$\begin{aligned} I_0 &= |\vec{I}_0| = |\vec{I}_{R0} + \vec{I}_{L0} + \vec{I}_{C0}| = \sqrt{I_{R0}^2 + (I_{C0} - I_{L0})^2} \\ &= V_0 \sqrt{\frac{1}{R^2} + \left(\omega C - \frac{1}{\omega L}\right)^2} = V_0 \sqrt{\frac{1}{R^2} + \left(\frac{1}{X_C} - \frac{1}{X_L}\right)^2} \end{aligned} \quad (12.6.7)$$

Note however, since $I_R(t)$, $I_L(t)$ and $I_C(t)$ are not in phase with one another, I_0 is not equal to the sum of the maximum amplitudes of the three currents:

$$I_0 \neq I_{R0} + I_{L0} + I_{C0} \quad (12.6.8)$$

With $I_0 = V_0 / Z$, the (inverse) impedance of the circuit is given by

$$\frac{1}{Z} = \sqrt{\frac{1}{R^2} + \left(\omega C - \frac{1}{\omega L}\right)^2} = \sqrt{\frac{1}{R^2} + \left(\frac{1}{X_C} - \frac{1}{X_L}\right)^2} \quad (12.6.9)$$

The relationship between Z , R , X_L and X_C is shown in Figure 12.6.3.

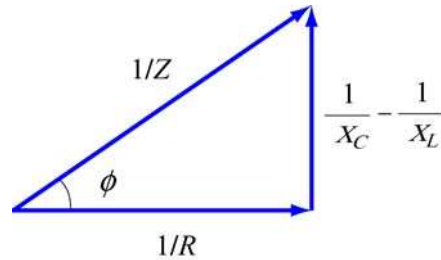

Figure 12.6.3 Relationship between Z , R , X_L and X_C in a parallel RLC circuit.

From the figure or the phasor diagram shown in Figure 12.6.2, we see that the phase can be obtained as

$$\tan \phi = \left(\frac{I_{C0} - I_{L0}}{I_{R0}} \right) = \frac{\frac{V_0}{X_C} - \frac{V_0}{X_L}}{\frac{V_0}{R}} = R \left(\frac{1}{X_C} - \frac{1}{X_L} \right) = R \left(\omega C - \frac{1}{\omega L} \right) \quad (12.6.10)$$

The resonance condition for the parallel RLC circuit is given by $\phi = 0$, which implies

$$\frac{1}{X_C} = \frac{1}{X_L} \quad (12.6.11)$$

The resonant frequency is

$$\omega_0 = \frac{1}{\sqrt{LC}} \quad (12.6.12)$$

which is the same as for the series RLC circuit. From Eq. (12.6.9), we readily see that $1/Z$ is minimum (or Z is maximum) at resonance. The current in the inductor exactly

cancels out the current in the capacitor, so that the total current in the circuit reaches a minimum, and is equal to the current in the resistor:

$$I_0 = \frac{V_0}{R} \quad (12.6.13)$$

As in the series *RLC* circuit, power is dissipated only through the resistor. The average power is



$$\langle P(t) \rangle = \langle I_R(t)V(t) \rangle = \langle I_R^2(t)R \rangle = \frac{V_0^2}{R} \langle \sin^2 \omega t \rangle = \frac{V_0^2}{2R} = \frac{V_0^2}{2Z} \left(\frac{Z}{R} \right) \quad (12.6.14)$$

Thus, the power factor in this case is

$$\text{power factor} = \frac{\langle P(t) \rangle}{V_0^2 / 2Z} = \frac{Z}{R} = \frac{1}{\sqrt{1 + \left(R\omega C - \frac{R}{\omega L} \right)^2}} = \cos \phi \quad (12.6.15)$$

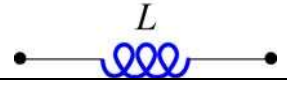

12.7 Summary

- In an AC circuit with a sinusoidal voltage source $V(t) = V_0 \sin \omega t$, the current is given by $I(t) = I_0 \sin(\omega t - \phi)$, where I_0 is the amplitude and ϕ is the phase constant. For simple circuit with only one element (a resistor, a capacitor or an inductor) connected to the voltage source, the results are as follows:

Circuit Elements	Resistance /Reactance	Current Amplitude	Phase angle ϕ
	R	$I_{R0} = \frac{V_0}{R}$	0
	$X_L = \omega L$	$I_{L0} = \frac{V_0}{X_L}$	$\pi/2$ current lags voltage by 90°
	$X_C = \frac{1}{\omega C}$	$I_{C0} = \frac{V_0}{X_C}$	$-\pi/2$ current leads voltage by 90°

where X_L is the **inductive reactance** and X_C is the **capacitive reactance**.

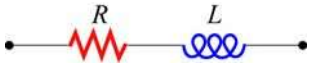
- For circuits which have more than one circuit element connected in series, the results are

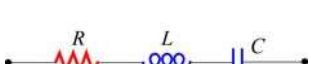
Circuit Elements	Impedance Z	Current Amplitude	Phase angle ϕ
	$\sqrt{R^2 + X_L^2}$	$I_0 = \frac{V_0}{\sqrt{R^2 + X_L^2}}$	$0 < \phi < \frac{\pi}{2}$
	$\sqrt{R^2 + X_C^2}$	$I_0 = \frac{V_0}{\sqrt{R^2 + X_C^2}}$	$-\frac{\pi}{2} < \phi < 0$
	$\sqrt{R^2 + (X_L - X_C)^2}$	$I_0 = \frac{V_0}{\sqrt{R^2 + (X_L - X_C)^2}}$	$\phi > 0$ if $X_L > X_C$ $\phi < 0$ if $X_L < X_C$

where Z is the **impedance** Z of the circuit. For a series RLC circuit, we have

$$Z = \sqrt{R^2 + (X_L - X_C)^2}$$

The phase angle between the voltage and the current in an AC circuit is

$$\phi = \tan^{-1} \left(\frac{X_L - X_C}{R} \right)$$

- In the parallel RLC circuit, the impedance is given by

$$\frac{1}{Z} = \sqrt{\frac{1}{R^2} + \left(\omega C - \frac{1}{\omega L} \right)^2} = \sqrt{\frac{1}{R^2} + \left(\frac{1}{X_C} - \frac{1}{X_L} \right)^2}$$

and the phase is

$$\phi = \tan^{-1} \left[R \left(\frac{1}{X_C} - \frac{1}{X_L} \right) \right] = \tan^{-1} \left[R \left(\omega C - \frac{1}{\omega L} \right) \right]$$

- The **rms** (root mean square) voltage and current in an AC circuit are given by

$$V_{\text{rms}} = \frac{V_0}{\sqrt{2}}, \quad I_{\text{rms}} = \frac{I_0}{\sqrt{2}}$$

- The average power of an AC circuit is

$$\langle P(t) \rangle = I_{\text{rms}} V_{\text{rms}} \cos \phi$$

where $\cos \phi$ is known as the **power factor**.

- The **resonant frequency** ω_0 is

$$\omega_0 = \frac{1}{\sqrt{LC}}$$

At **resonance**, the current in the series RLC circuit reaches the maximum, but the current in the parallel RLC circuit is at a minimum.

- The **transformer equation** is

$$\frac{V_2}{V_1} = \frac{N_2}{N_1}$$

where V_1 is the voltage source in the primary coil with N_1 turns, and V_2 is the output voltage in the secondary coil with N_2 turns. A transformer with $N_2 > N_1$ is called a *step-up* transformer, and a transformer with $N_2 < N_1$ is called a *step-down* transformer.

12.8 Problem-Solving Tips

In this chapter, we have seen how phasors provide a powerful tool for analyzing the AC circuits. Below are some important tips:

1. Keep in mind the phase relationships for simple circuits
 - (1) For a resistor, the voltage and the phase are always in phase.
 - (2) For an inductor, the current lags the voltage by 90° .
 - (3) For a capacitor, the current leads to voltage by 90° .
2. When circuit elements are connected in *series*, the instantaneous current is the same for all elements, and the instantaneous voltages across the elements are out of phase. On the other hand, when circuit elements are connected in *parallel*, the instantaneous voltage is the same for all elements, and the instantaneous currents across the elements are out of phase.
3. For series connection, draw a phasor diagram for the voltages. The amplitudes of the voltage drop across all the circuit elements involved should be represented with phasors. In Figure 12.8.1 the phasor diagram for a series RLC circuit is shown for both the inductive case $X_L > X_C$ and the capacitive case $X_L < X_C$.

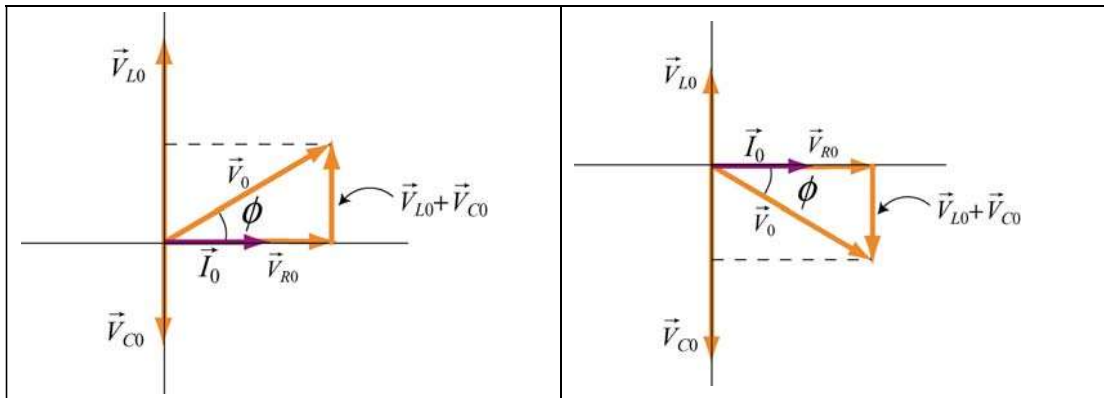

Figure 12.8.1 Phasor diagram for the series RLC circuit for (a) $X_L > X_C$ and (b) $X_L < X_C$.

From Figure 12.8.1(a), we see that $V_{L0} > V_{C0}$ in the inductive case and \vec{V}_0 leads \vec{I}_0 by a phase ϕ . On the other hand, in the capacitive case shown in Figure 12.8.1(b), $V_{C0} > V_{L0}$ and \vec{I}_0 leads \vec{V}_0 by a phase ϕ .

4. When $V_{L0} = V_{C0}$, or $\phi = 0$, the circuit is at resonance. The corresponding resonant frequency is $\omega_0 = 1/\sqrt{LC}$, and the power delivered to the resistor is a maximum.
5. For parallel connection, draw a phasor diagram for the currents. The amplitudes of the currents across all the circuit elements involved should be represented with phasors. In Figure 12.8.2 the phasor diagram for a parallel RLC circuit is shown for both the inductive case $X_L > X_C$ and the capacitive case $X_L < X_C$.

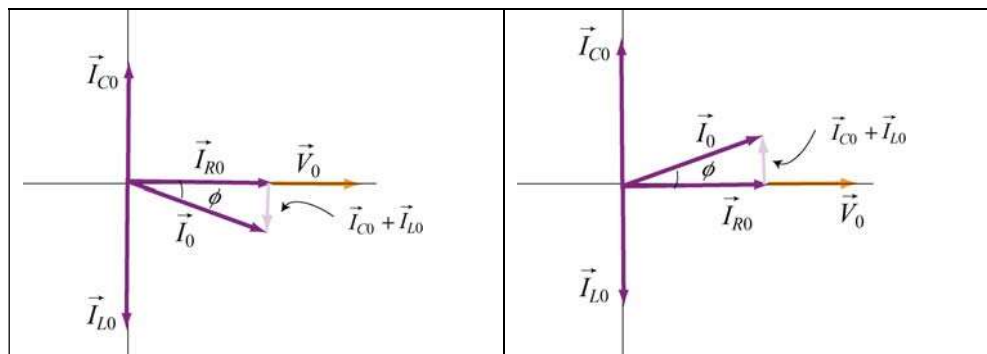

Figure 12.8.2 Phasor diagram for the parallel RLC circuit for (a) $X_L > X_C$ and (b) $X_L < X_C$.

From Figure 12.8.2(a), we see that $I_{L0} > I_{C0}$ in the inductive case and \vec{V}_0 leads \vec{I}_0 by a phase ϕ . On the other hand, in the capacitive case shown in Figure 12.8.2(b), $I_{C0} > I_{L0}$ and \vec{I}_0 leads \vec{V}_0 by a phase ϕ .

12.9 Solved Problems

12.9.1 RLC Series Circuit

A series *RLC* circuit with $L = 160 \text{ mH}$, $C = 100 \mu\text{F}$, and $R = 40.0 \Omega$ is connected to a sinusoidal voltage $V(t) = (40.0 \text{ V}) \sin \omega t$, with $\omega = 200 \text{ rad/s}$.

- (a) What is the impedance of the circuit?
- (b) Let the current at any instant in the circuit be $I(t) = I_0 \sin(\omega t - \phi)$. Find I_0 .
- (c) What is the phase ϕ ?

Solution:

- (a) The impedance of a series *RLC* circuit is given by

$$Z = \sqrt{R^2 + (X_L - X_C)^2} \quad (12.9.1)$$

where

$$X_L = \omega L \quad (12.9.2)$$

and

$$X_C = \frac{1}{\omega C} \quad (12.9.3)$$

are the inductive reactance and the capacitive reactance, respectively. Since the general expression of the voltage source is $V(t) = V_0 \sin(\omega t)$, where V_0 is the maximum output voltage and ω is the angular frequency, we have $V_0 = 40 \text{ V}$ and $\omega = 200 \text{ rad/s}$. Thus, the impedance Z becomes

$$\begin{aligned} Z &= \sqrt{(40.0 \Omega)^2 + \left((200 \text{ rad/s})(0.160 \text{ H}) - \frac{1}{(200 \text{ rad/s})(100 \times 10^{-6} \text{ F})} \right)^2} \\ &= 43.9 \Omega \end{aligned} \quad (12.9.4)$$

- (b) With $V_0 = 40.0 \text{ V}$, the amplitude of the current is given by

$$I_0 = \frac{V_0}{Z} = \frac{40.0 \text{ V}}{43.9 \Omega} = 0.911 \text{ A} \quad (12.9.5)$$

(c) The phase between the current and the voltage is determined by

$$\begin{aligned}\phi &= \tan^{-1}\left(\frac{X_L - X_C}{R}\right) = \tan^{-1}\left(\frac{\omega L - \frac{1}{\omega C}}{R}\right) \\ &= \tan^{-1}\left(\frac{(200 \text{ rad/s})(0.160 \text{ H}) - \frac{1}{(200 \text{ rad/s})(100 \times 10^{-6} \text{ F})}}{40.0 \Omega}\right) = -24.2^\circ\end{aligned}\quad (12.9.6)$$

12.9.2 RLC Series Circuit

Suppose an AC generator with $V(t) = (150 \text{ V})\sin(100t)$ is connected to a series RLC circuit with $R = 40.0 \Omega$, $L = 80.0 \text{ mH}$, and $C = 50.0 \mu\text{F}$, as shown in Figure 12.9.1.

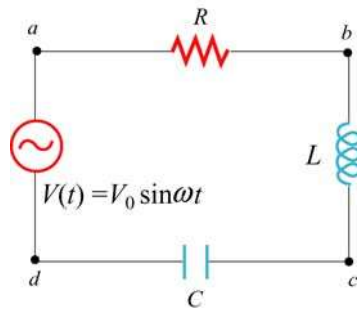

Figure 12.9.1 RLC series circuit

- (a) Calculate V_{R0} , V_{L0} and V_{C0} , the maximum of the voltage drops across each circuit element.
- (b) Calculate the maximum potential difference across the inductor and the capacitor between points b and d shown in Figure 12.9.1.

Solutions:

(a) The inductive reactance, capacitive reactance and the impedance of the circuit are given by

$$X_C = \frac{1}{\omega C} = \frac{1}{(100 \text{ rad/s})(50.0 \times 10^{-6} \text{ F})} = 200 \Omega \quad (12.9.7)$$

$$X_L = \omega L = (100 \text{ rad/s})(80.0 \times 10^{-3} \text{ H}) = 8.00 \Omega \quad (12.9.8)$$

and

$$Z = \sqrt{R^2 + (X_L - X_C)^2} = \sqrt{(40.0 \, \Omega)^2 + (8.00 \, \Omega - 200 \, \Omega)^2} = 196 \, \Omega \quad (12.9.9)$$

respectively. Therefore, the corresponding maximum current amplitude is

$$I_0 = \frac{V_0}{Z} = \frac{150 \, \text{V}}{196 \, \Omega} = 0.765 \, \text{A} \quad (12.9.10)$$

The maximum voltage across the resistance would be just the product of maximum current and the resistance:

$$V_{R0} = I_0 R = (0.765 \, \text{A})(40.0 \, \Omega) = 30.6 \, \text{V} \quad (12.9.11)$$

Similarly, the maximum voltage across the inductor is

$$V_{L0} = I_0 X_L = (0.765 \, \text{A})(8.00 \, \Omega) = 6.12 \, \text{V} \quad (12.9.12)$$

and the maximum voltage across the capacitor is

$$V_{C0} = I_0 X_C = (0.765 \, \text{A})(200 \, \Omega) = 153 \, \text{V} \quad (12.9.13)$$

Note that the maximum input voltage V_0 is related to V_{R0} , V_{L0} and V_{C0} by

$$V_0 = \sqrt{V_{R0}^2 + (V_{L0} - V_{C0})^2} \quad (12.9.14)$$

(b) From b to d , the maximum voltage would be the difference between V_{L0} and V_{C0} :

$$|V_{bd}| = |\vec{V}_{L0} + \vec{V}_{C0}| = |V_{L0} - V_{C0}| = |6.12 \, \text{V} - 153 \, \text{V}| = 147 \, \text{V} \quad (12.9.15)$$

12.9.3 Resonance

A sinusoidal voltage $V(t) = (200 \, \text{V}) \sin \omega t$ is applied to a series RLC circuit with $L = 10.0 \, \text{mH}$, $C = 100 \, \text{nF}$ and $R = 20.0 \, \Omega$. Find the following quantities:

- the resonant frequency,
- the amplitude of the current at resonance,
- the quality factor Q of the circuit, and

(d) the amplitude of the voltage across the inductor at the resonant frequency.

Solution:

(a) The resonant frequency for the circuit is given by

$$f = \frac{\omega_0}{2\pi} = \frac{1}{2\pi} \sqrt{\frac{1}{LC}} = \frac{1}{2\pi} \sqrt{\frac{1}{(10.0 \times 10^{-3} \text{ H})(100 \times 10^{-9} \text{ F})}} = 5033 \text{ Hz} \quad (12.9.16)$$

(b) At resonance, the current is

$$I_0 = \frac{V_0}{R} = \frac{200 \text{ V}}{20.0 \ \Omega} = 10.0 \text{ A} \quad (12.9.17)$$

(c) The quality factor Q of the circuit is given by

$$Q = \frac{\omega_0 L}{R} = \frac{2\pi(5033 \text{ s}^{-1})(10.0 \times 10^{-3} \text{ H})}{(20.0 \ \Omega)} = 15.8 \quad (12.9.18)$$

(d) At resonance, the amplitude of the voltage across the inductor is

$$V_{L0} = I_0 X_L = I_0 \omega_0 L = (10.0 \text{ A}) 2\pi(5033 \text{ s}^{-1})(10.0 \times 10^{-3} \text{ H}) = 3.16 \times 10^3 \text{ V} \quad (12.9.19)$$

12.9.4 *RL* High-Pass Filter

An *RL* high-pass filter (circuit that filters out low-frequency AC currents) can be represented by the circuit in Figure 12.9.2, where R is the internal resistance of the inductor.

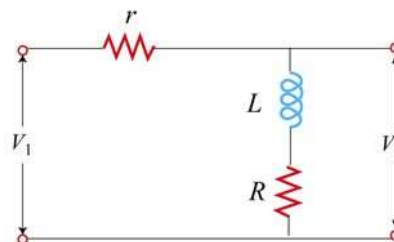

Figure 12.9.2 *RL* filter

(a) Find V_{20}/V_{10} , the ratio of the maximum output voltage V_{20} to the maximum input voltage V_{10} .

(b) Suppose $r=15.0\ \Omega$, $R=10\ \Omega$ and $L=250\ \text{mH}$. Find the frequency at which $V_{20}/V_{10}=1/2$.

Solution:

(a) The impedance for the input circuit is $Z_1 = \sqrt{(R+r)^2 + X_L^2}$ where $X_L = \omega L$ and $Z_2 = \sqrt{R^2 + X_L^2}$ for the output circuit. The maximum current is given by

$$I_0 = \frac{V_{10}}{Z_1} = \frac{V_0}{\sqrt{(R+r)^2 + X_L^2}} \quad (12.9.20)$$

Similarly, the maximum output voltage is related to the output impedance by

$$V_{20} = I_0 Z_2 = I_0 \sqrt{R^2 + X_L^2} \quad (12.9.21)$$

This implies

$$\frac{V_{20}}{V_{10}} = \frac{\sqrt{R^2 + X_L^2}}{\sqrt{(R+r)^2 + X_L^2}} \quad (12.9.22)$$

(b) For $V_{20}/V_{10}=1/2$, we have

$$\frac{R^2 + X_L^2}{(R+r)^2 + X_L^2} = \frac{1}{4} \Rightarrow X_L = \sqrt{\frac{(R+r)^2 - 4R^2}{3}} \quad (12.9.23)$$

Since $X_L = \omega L = 2\pi fL$, the frequency which yields this ratio is

$$f = \frac{X_L}{2\pi L} = \frac{1}{2\pi(0.250\ \text{H})} \sqrt{\frac{(10.0\ \Omega + 15.0\ \Omega)^2 - 4(10.0\ \Omega)^2}{3}} = 5.51\ \text{Hz} \quad (12.9.24)$$

12.9.5 RLC Circuit

Consider the circuit shown in Figure 12.9.3. The sinusoidal voltage source is $V(t) = V_0 \sin \omega t$. If both switches S_1 and S_2 are closed initially, find the following quantities, ignoring the transient effect and assuming that R , L , V_0 and ω are known:

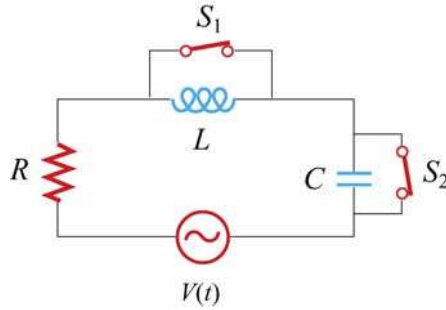

Figure 12.9.3

- (a) the current $I(t)$ as a function of time,
- (b) the average power delivered to the circuit,
- (c) the current as a function of time a long time after only S_1 is opened.
- (d) the capacitance C if both S_1 and S_2 are opened for a long time, with the current and voltage in phase.
- (e) the impedance of the circuit when both S_1 and S_2 are opened.
- (f) the maximum energy stored in the capacitor during oscillations.
- (g) the maximum energy stored in the inductor during oscillations.
- (h) the phase difference between the current and the voltage if the frequency of $V(t)$ is doubled.
- (i) the frequency at which the inductive reactance X_L is equal to half the capacitive reactance X_C .

Solutions:

- (a) When both switches S_1 and S_2 are closed, the current goes through only the generator and the resistor, so the total impedance of the circuit is R and the current is

$$I_R(t) = \frac{V_0}{R} \sin \omega t \quad (12.9.25)$$

- (b) The average power is given by

$$\langle P(t) \rangle = \langle I_R(t)V(t) \rangle = \frac{V_0^2}{R} \langle \sin^2 \omega t \rangle = \frac{V_0^2}{2R} \quad (12.9.26)$$

(c) If only S_1 is opened, after a long time the current will pass through the generator, the resistor and the inductor. For this RL circuit, the impedance becomes

$$Z = \frac{1}{\sqrt{R^2 + X_L^2}} = \frac{1}{\sqrt{R^2 + \omega^2 L^2}} \quad (12.9.27)$$

and the phase angle ϕ is

$$\phi = \tan^{-1}\left(\frac{\omega L}{R}\right) \quad (12.9.28)$$

Thus, the current as a function of time is

$$I(t) = I_0 \sin(\omega t - \phi) = \frac{V_0}{\sqrt{R^2 + \omega^2 L^2}} \sin\left(\omega t - \tan^{-1} \frac{\omega L}{R}\right) \quad (12.9.29)$$

Note that in the limit of vanishing resistance $R = 0$, $\phi = \pi/2$, and we recover the expected result for a purely inductive circuit.

(d) If both switches are opened, then this would be a driven RLC circuit, with the phase angle ϕ given by

$$\tan \phi = \frac{X_L - X_C}{R} = \frac{\omega L - \frac{1}{\omega C}}{R} \quad (12.9.30)$$

If the current and the voltage are in phase, then $\phi = 0$, implying $\tan \phi = 0$. Let the corresponding angular frequency be ω_0 ; we then obtain

$$\omega_0 L = \frac{1}{\omega_0 C} \quad (12.9.31)$$

and the capacitance is

$$C = \frac{1}{\omega_0^2 L} \quad (12.9.32)$$

(e) From (d), we see that when both switches are opened, the circuit is at resonance with $X_L = X_C$. Thus, the impedance of the circuit becomes

$$Z = \sqrt{R^2 + (X_L - X_C)^2} = R \quad (12.9.33)$$

(f) The electric energy stored in the capacitor is

$$U_E = \frac{1}{2} CV_C^2 = \frac{1}{2} C(IX_C)^2 \quad (12.9.34)$$

It attains maximum when the current is at its maximum I_0 :

$$U_{C,\max} = \frac{1}{2} CI_0^2 X_C^2 = \frac{1}{2} C \left(\frac{V_0}{R} \right)^2 \frac{1}{\omega_0^2 C^2} = \frac{V_0^2 L}{2R^2} \quad (12.9.35)$$

where we have used $\omega_0^2 = 1/LC$.

(g) The maximum energy stored in the inductor is given by

$$U_{L,\max} = \frac{1}{2} LI_0^2 = \frac{LV_0^2}{2R^2} \quad (12.9.36)$$

(h) If the frequency of the voltage source is doubled, i.e., $\omega = 2\omega_0 = 1/\sqrt{LC}$, then the phase becomes

$$\phi = \tan^{-1} \left(\frac{\omega L - 1/\omega C}{R} \right) = \tan^{-1} \left(\frac{(2/\sqrt{LC})L - (\sqrt{LC}/2C)}{R} \right) = \tan^{-1} \left(\frac{3}{2R} \sqrt{\frac{L}{C}} \right) \quad (12.9.37)$$

(i) If the inductive reactance is one-half the capacitive reactance,

$$X_L = \frac{1}{2} X_C \Rightarrow \omega L = \frac{1}{2} \left(\frac{1}{\omega C} \right) \quad (12.9.38)$$

then

$$\omega = \frac{1}{\sqrt{2LC}} = \frac{\omega_0}{\sqrt{2}} \quad (12.9.39)$$

12.9.6 RL Filter

The circuit shown in Figure 12.9.4 represents an RL filter.

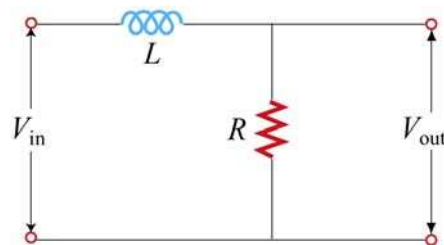

Figure 12.9.4

Let the inductance be $L = 400 \text{ mH}$, and the input voltage $V_{\text{in}} = (20.0 \text{ V})\sin \omega t$, where $\omega = 200 \text{ rad/s}$.

(a) What is the value of R such that the output voltage lags behind the input voltage by 30.0° ?

(b) Find the ratio of the amplitude of the output and the input voltages. What type of filter is this circuit, high-pass or low-pass?

(c) If the positions of the resistor and the inductor are switched, would the circuit be a high-pass or a low-pass filter?

Solutions:

(a) The phase relationship between V_L and V_R is given by

$$\tan \phi = \frac{V_L}{V_R} = \frac{IX_L}{IX_R} = \frac{\omega L}{R} \quad (12.9.40)$$

Thus, we have

$$R = \frac{\omega L}{\tan \phi} = \frac{(200 \text{ rad/s})(0.400 \text{ H})}{\tan 30.0^\circ} = 139 \Omega \quad (12.9.41)$$

(b) The ratio is given by

$$\frac{V_{\text{out}}}{V_{\text{in}}} = \frac{V_R}{V_{\text{in}}} = \frac{R}{\sqrt{R^2 + X_L^2}} = \cos \phi = \cos 30.0^\circ = 0.866. \quad (12.9.42)$$

The circuit is a low-pass filter, since the ratio $V_{\text{out}}/V_{\text{in}}$ decreases with increasing ω .

(c) In this case, the circuit diagram is

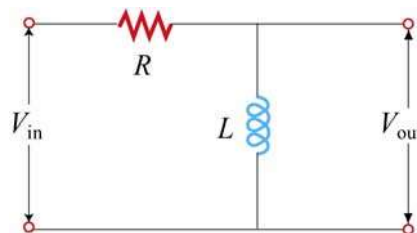

Figure 12.9.5 RL high-pass filter

The ratio of the output voltage to the input voltage would be

$$\frac{V_{\text{out}}}{V_{\text{in}}} = \frac{V_L}{V_{\text{in}}} = \frac{X_L}{\sqrt{R^2 + X_L^2}} = \frac{\omega^2 L^2}{\sqrt{R^2 + \omega^2 L^2}} = \left[1 + \left(\frac{R}{\omega L} \right)^2 \right]^{-1/2}$$

The circuit is a high-pass filter, since the ratio $V_{\text{out}}/V_{\text{in}}$ approaches one in the large- ω limit.

12.10 Conceptual Questions

- Consider a purely capacitive circuit (a capacitor connected to an AC source).
 - How does the capacitive reactance change if the driving frequency is doubled? halved?
 - Are there any times when the capacitor is supplying power to the AC source?
- If the applied voltage leads the current in a series RLC circuit, is the frequency above or below resonance?
- Consider the phasor diagram shown in Figure 12.10.1 for an RLC circuit.

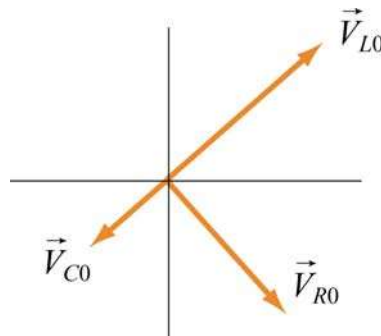

- Is the driving frequency above or below the resonant frequency?
 - Draw the phasor \vec{V}_0 associated with the amplitude of the applied voltage.
 - Give an estimate of the phase ϕ between the applied AC voltage and the current.
- How does the power factor in an RLC circuit change with resistance R , inductance L and capacitance C ?
 - Can a battery be used as the primary voltage source in a transformer?

6. If the power factor in an RLC circuit is $\cos \phi = 1/2$, can you tell whether the current leading or lagging the voltage? Explain.

12.11 Additional Problems

12.11.1 Reactance of a Capacitor and an Inductor

(a) A $C = 0.5\text{-}\mu\text{F}$ capacitor is connected, as shown in Figure 12.11.1(a), to an AC generator with $V_0 = 300\text{ V}$. What is the amplitude I_0 of the resulting alternating current if the angular frequency ω is (i) 100 rad/s , and (ii) 1000 rad/s ?

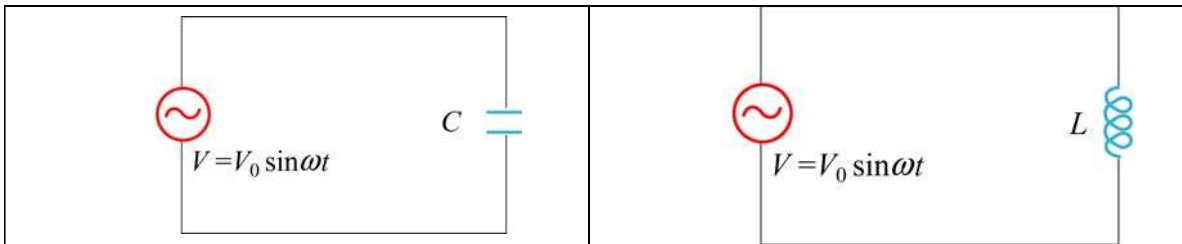

Figure 12.11.1 (a) A purely capacitive circuit, and (b) a purely inductive circuit.

(b) A 45-mH inductor is connected, as shown in Figure 12.10.1(b), to an AC generator with $V_0 = 300\text{ V}$. The inductor has a reactance $X_L = 1300\ \Omega$. What must be

- (i) the applied angular frequency ω and
- (ii) the applied frequency f for this to be true?
- (iii) What is the amplitude I_0 of the resulting alternating current?

(c) At what frequency f would our $0.5\text{-}\mu\text{F}$ capacitor and our 45-mH inductor have the same reactance? What would this reactance be? How would this frequency compare to the natural resonant frequency of free oscillations if the components were connected as an LC oscillator with zero resistance?

12.11.2 Driven RLC Circuit Near Resonance

The circuit shown in Figure 12.11.2 contains an inductor L , a capacitor C , and a resistor R in series with an AC generator which provides a source of sinusoidally varying emf $V(t) = V_0 \sin \omega t$.

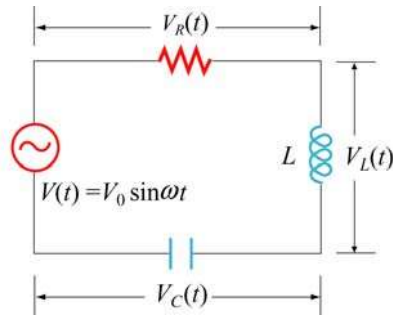

Figure 12.11.2

This emf drives current $I(t) = I_0 \sin(\omega t - \phi)$ through the circuit at angular frequency ω .

- At what angular frequency ω will the circuit resonate with maximum response, as measured by the amplitude I_0 of the current in the circuit? What is the value of the maximum current amplitude I_{\max} ?
- What is the value of the phase angle ϕ between $V(t)$ and $I(t)$ at this resonant frequency?
- Suppose the frequency ω is *increased* from the resonance value until the amplitude I_0 of the current decreases from I_{\max} to $I_{\max} / \sqrt{2}$. Now what is the phase difference ϕ between the emf and the current? Does the current lead or lag the emf?

12.11.3 RC Circuit

A series RC circuit with $R = 4.0 \times 10^3 \Omega$ and $C = 0.40 \mu\text{F}$ is connected to an AC voltage source $V(t) = (100 \text{ V}) \sin \omega t$, with $\omega = 200 \text{ rad/s}$.

- What is the rms current in the circuit?
- What is the phase between the voltage and the current?
- Find the power dissipated in the circuit.
- Find the voltage drop both across the resistor and the capacitor.

12.11.4 Black Box

An AC voltage source is connected to a “black box” which contains a circuit, as shown in Figure 12.11.3.

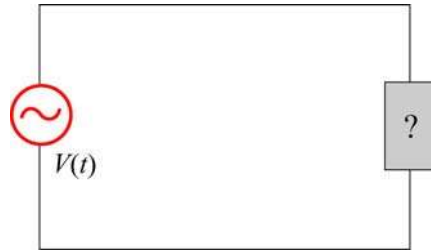

Figure 12.11.3 A “black box” connected to an AC voltage source.

The elements in the circuit and their arrangement, however, are unknown. Measurements outside the black box provide the following information:

$$V(t) = (80 \text{ V}) \sin \omega t$$

$$I(t) = (1.6 \text{ A}) \sin(\omega t + 45^\circ)$$

- (a) Does the current lead or lag the voltage?
- (b) Is the circuit in the black box largely capacitive or inductive?
- (c) Is the circuit in the black box at resonance?
- (d) What is the power factor?
- (e) Does the box contain a resistor? A capacitor? An inductor?
- (f) Compute the average power delivered to the black box by the AC source.

12.11.5 Parallel RL Circuit

Consider the parallel RL circuit shown in Figure 12.11.4.

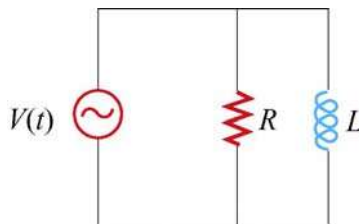

Figure 12.11.4 Parallel RL circuit

The AC voltage source is $V(t) = V_0 \sin \omega t$.

- (a) Find the current across the resistor.

- (b) Find the current across the inductor.
- (c) What is the magnitude of the total current?
- (d) Find the impedance of the circuit.
- (e) What is the phase angle between the current and the voltage?

12.11.6 LC Circuit

Suppose at $t=0$ the capacitor in the LC circuit is fully charged to Q_0 . At a later time $t=T/6$, where T is the period of the LC oscillation, find the ratio of each of the following quantities to its maximum value:

- (a) charge on the capacitor,
- (b) energy stored in the capacitor,
- (c) current in the inductor, and
- (d) energy in the inductor.

12.11.7 Parallel RC Circuit

Consider the parallel RC circuit shown in Figure 12.11.5.

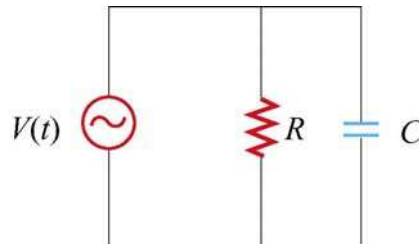

Figure 12.11.5 Parallel RC circuit

The AC voltage source is $V(t) = V_0 \sin \omega t$.

- (a) Find the current across the resistor.
- (b) Find the current across the capacitor.
- (c) What is the magnitude of the total current?

- (d) Find the impedance of the circuit.
- (e) What is the phase angle between the current and the voltage?

12.11.8 Power Dissipation

A series RLC circuit with $R=10.0\ \Omega$, $L=400\ \text{mH}$ and $C=2.0\ \mu\text{F}$ is connected to an AC voltage source which has a maximum amplitude $V_0=100\ \text{V}$.

- (a) What is the resonant frequency ω_0 ?
- (b) Find the rms current at resonance.
- (c) Let the driving frequency be $\omega=4000\ \text{rad/s}$. Compute X_C , X_L , Z and ϕ .

12.11.9 FM Antenna

An FM antenna circuit (shown in Figure 12.11.6) has an inductance $L=10^{-6}\ \text{H}$, a capacitance $C=10^{-12}\ \text{F}$ and a resistance $R=100\ \Omega$. A radio signal induces a sinusoidally alternating emf in the antenna with an amplitude of $10^{-5}\ \text{V}$.

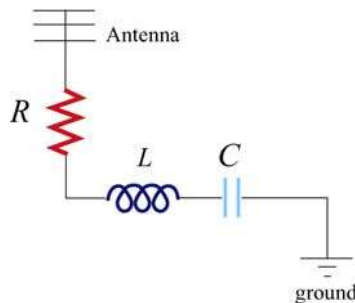

Figure 12.11.6

- (a) For what angular frequency ω_0 (radians/sec) of the incoming waves will the circuit be “in tune”-- that is, for what ω_0 will the current in the circuit be a maximum.
- (b) What is the quality factor Q of the resonance?
- (c) Assuming that the incoming wave is “in tune,” what will be the amplitude of the current in the circuit at this “in tune” frequency.
- (d) What is the amplitude of the potential difference across the capacitor at this “in tune” frequency?

12.11.10 Driven RLC Circuit

Suppose you want a series RLC circuit to tune to your favorite FM radio station that broadcasts at a frequency of 89.7 MHz. You would like to avoid the obnoxious station that broadcasts at 89.5 MHz. In order to achieve this, for a given input voltage signal from your antenna, you want the width of your resonance to be narrow enough at 89.7 MHz such that the current flowing in your circuit will be 10^{-2} times less at 89.5 MHz than at 89.7 MHz. You cannot avoid having a resistance of $R = 0.1 \Omega$, and practical considerations also dictate that you use the minimum L possible.

- (a) In terms of your circuit parameters, L , R and C , what is the amplitude of your current in your circuit as a function of the angular frequency of the input signal?
- (b) What is the angular frequency of the input signal at the desired resonance?
- (c) What values of L and C must you use?
- (d) What is the quality factor for this resonance?
- (e) Show that at resonance, the ratio of the amplitude of the voltage across the inductor with the driving signal amplitude is the quality of the resonance.
- (f) Show that at resonance the ratio of the amplitude of the voltage across the capacitor with the driving signal amplitude is the quality of the resonance.
- (g) What is the time averaged power at resonance that the signal delivers to the circuit?
- (h) What is the phase shift for the input signal at 89.5 MHz?
- (i) What is the time averaged power for the input signal at 89.5 MHz?
- (j) Is the circuit capacitive or inductive at 89.5 MHz?

Chapter 13

Maxwell's Equations and Electromagnetic Waves

13.1	The Displacement Current.....	2
13.2	Gauss's Law for Magnetism.....	4
13.3	Maxwell's Equations.....	4
13.4	Plane Electromagnetic Waves.....	6
13.4.1	One-Dimensional Wave Equation.....	9
13.5	Standing Electromagnetic Waves.....	12
13.6	Poynting Vector.....	14
Example 13.1:	Solar Constant.....	16
Example 13.2:	Intensity of a Standing Wave.....	18
13.6.1	Energy Transport.....	18
13.7	Momentum and Radiation Pressure.....	21
13.8	Production of Electromagnetic Waves.....	22
Animation 13.1:	Electric Dipole Radiation 1.....	24
Animation 13.2:	Electric Dipole Radiation 2.....	24
Animation 13.3:	Radiation From a Quarter-Wave Antenna.....	25
13.8.1	Plane Waves.....	25
13.8.2	Sinusoidal Electromagnetic Wave.....	30
13.9	Summary.....	32
13.10	Appendix: Reflection of Electromagnetic Waves at Conducting Surfaces.....	34
13.11	Problem-Solving Strategy: Traveling Electromagnetic Waves.....	38
13.12	Solved Problems.....	40
13.12.1	Plane Electromagnetic Wave.....	40
13.12.2	One-Dimensional Wave Equation.....	41
13.12.3	Poynting Vector of a Charging Capacitor.....	42
13.12.4	Poynting Vector of a Conductor.....	44
13.13	Conceptual Questions.....	45
13.14	Additional Problems.....	46
13.14.1	Solar Sailing.....	46

13.14.2 Reflections of True Love	46
13.14.3 Coaxial Cable and Power Flow.....	46
13.14.4 Superposition of Electromagnetic Waves.....	47
13.14.5 Sinusoidal Electromagnetic Wave	47
13.14.6 Radiation Pressure of Electromagnetic Wave.....	48
13.14.7 Energy of Electromagnetic Waves.....	48
13.14.8 Wave Equation.....	49
13.14.9 Electromagnetic Plane Wave	49
13.14.10 Sinusoidal Electromagnetic Wave	49

Maxwell's Equations and Electromagnetic Waves

13.1 The Displacement Current

In Chapter 9, we learned that if a current-carrying wire possesses certain symmetry, the magnetic field can be obtained by using Ampere's law:

$$\oint \vec{\mathbf{B}} \cdot d\vec{\mathbf{s}} = \mu_0 I_{\text{enc}} \quad (13.1.1)$$

The equation states that the line integral of a magnetic field around an arbitrary closed loop is equal to $\mu_0 I_{\text{enc}}$, where I_{enc} is the conduction current passing through the surface bound by the closed path. In addition, we also learned in Chapter 10 that, as a consequence of the Faraday's law of induction, a changing magnetic field can produce an electric field, according to

$$\oint \vec{\mathbf{E}} \cdot d\vec{\mathbf{s}} = -\frac{d}{dt} \iint_S \vec{\mathbf{B}} \cdot d\vec{\mathbf{A}} \quad (13.1.2)$$

One might then wonder whether or not the converse could be true, namely, a changing electric field produces a magnetic field. If so, then the right-hand side of Eq. (13.1.1) will have to be modified to reflect such "symmetry" between $\vec{\mathbf{E}}$ and $\vec{\mathbf{B}}$.

To see how magnetic fields can be created by a time-varying electric field, consider a capacitor which is being charged. During the charging process, the electric field strength increases with time as more charge is accumulated on the plates. The conduction current that carries the charges also produces a magnetic field. In order to apply Ampere's law to calculate this field, let us choose curve C shown in Figure 13.1.1 to be the Amperian loop.

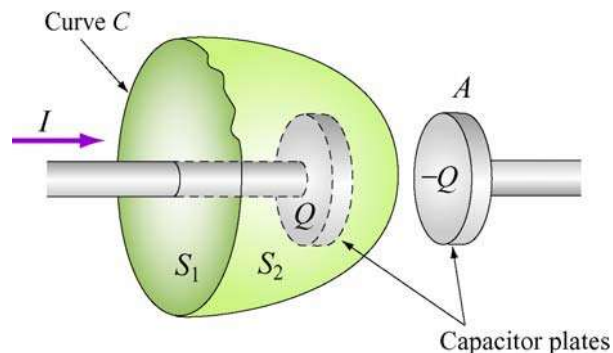

Figure 13.1.1 Surfaces S_1 and S_2 bound by curve C .

If the surface bounded by the path is the flat surface S_1 , then the enclosed current is $I_{\text{enc}} = I$. On the other hand, if we choose S_2 to be the surface bounded by the curve, then $I_{\text{enc}} = 0$ since no current passes through S_2 . Thus, we see that there exists an ambiguity in choosing the appropriate surface bounded by the curve C .

Maxwell showed that the ambiguity can be resolved by adding to the right-hand side of the Ampere's law an extra term

$$I_d = \epsilon_0 \frac{d\Phi_E}{dt} \quad (13.1.3)$$

which he called the “*displacement current*.” The term involves a change in electric flux. The generalized Ampere's (or the Ampere-Maxwell) law now reads

$$\oint \vec{B} \cdot d\vec{s} = \mu_0 I + \mu_0 \epsilon_0 \frac{d\Phi_E}{dt} = \mu_0 (I + I_d) \quad (13.1.4)$$

The origin of the displacement current can be understood as follows:

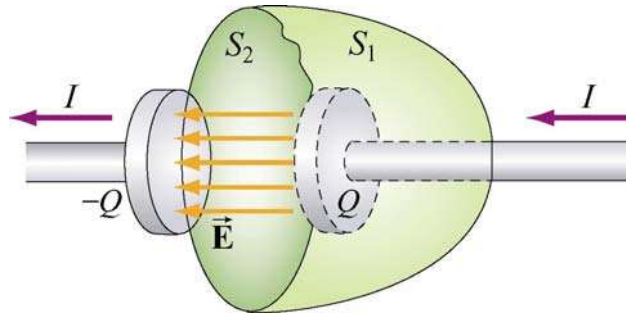

Figure 13.1.2 Displacement through S_2

In Figure 13.1.2, the electric flux which passes through S_2 is given by

$$\Phi_E = \oiint_S \vec{E} \cdot d\vec{A} = EA = \frac{Q}{\epsilon_0} \quad (13.1.5)$$

where A is the area of the capacitor plates. From Eq. (13.1.3), we readily see that the displacement current I_d is related to the rate of increase of charge on the plate by

$$I_d = \epsilon_0 \frac{d\Phi_E}{dt} = \frac{dQ}{dt} \quad (13.1.6)$$

However, the right-hand-side of the expression, dQ/dt , is simply equal to the conduction current, I . Thus, we conclude that the conduction current that passes through S_1 is

precisely equal to the displacement current that passes through S_2 , namely $I = I_d$. With the Ampere-Maxwell law, the ambiguity in choosing the surface bound by the Amperian loop is removed.

13.2 Gauss's Law for Magnetism

We have seen that Gauss's law for electrostatics states that the electric flux through a closed surface is proportional to the charge enclosed (Figure 13.2.1a). The electric field lines originate from the positive charge (source) and terminate at the negative charge (sink). One would then be tempted to write down the magnetic equivalent as

$$\Phi_B = \oiint_S \vec{\mathbf{B}} \cdot d\vec{\mathbf{A}} = \frac{Q_m}{\mu_0} \quad (13.2.1)$$

where Q_m is the magnetic charge (monopole) enclosed by the Gaussian surface. However, despite intense search effort, no isolated magnetic monopole has ever been observed. Hence, $Q_m = 0$ and Gauss's law for magnetism becomes

$$\Phi_B = \oiint_S \vec{\mathbf{B}} \cdot d\vec{\mathbf{A}} = 0 \quad (13.2.2)$$

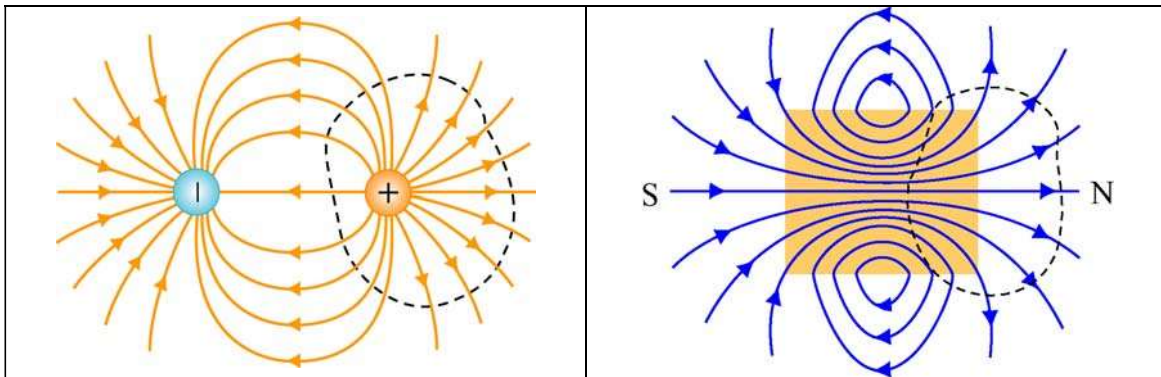

Figure 13.2.1 Gauss's law for (a) electrostatics, and (b) magnetism.

This implies that the number of magnetic field lines entering a closed surface is equal to the number of field lines leaving the surface. That is, there is no source or sink. In addition, the lines must be continuous with no starting or end points. In fact, as shown in Figure 13.2.1(b) for a bar magnet, the field lines that emanate from the north pole to the south pole outside the magnet return within the magnet and form a closed loop.

13.3 Maxwell's Equations

We now have four equations which form the foundation of electromagnetic phenomena:

Law	Equation	Physical Interpretation
Gauss's law for $\vec{\mathbf{E}}$	$\oiint_S \vec{\mathbf{E}} \cdot d\vec{\mathbf{A}} = \frac{Q}{\epsilon_0}$	Electric flux through a closed surface is proportional to the charged enclosed
Faraday's law	$\oint \vec{\mathbf{E}} \cdot d\vec{\mathbf{s}} = -\frac{d\Phi_B}{dt}$	Changing magnetic flux produces an electric field
Gauss's law for $\vec{\mathbf{B}}$	$\oiint_S \vec{\mathbf{B}} \cdot d\vec{\mathbf{A}} = 0$	The total magnetic flux through a closed surface is zero
Ampere – Maxwell law	$\oint \vec{\mathbf{B}} \cdot d\vec{\mathbf{s}} = \mu_0 I + \mu_0 \epsilon_0 \frac{d\Phi_E}{dt}$	Electric current and changing electric flux produces a magnetic field

Collectively they are known as Maxwell's equations. The above equations may also be written in differential forms as

$$\begin{aligned}
\nabla \cdot \vec{\mathbf{E}} &= \frac{\rho}{\epsilon_0} \\
\nabla \times \vec{\mathbf{E}} &= -\frac{\partial \vec{\mathbf{B}}}{\partial t} \\
\nabla \cdot \vec{\mathbf{B}} &= 0 \\
\nabla \times \vec{\mathbf{B}} &= \mu_0 \vec{\mathbf{J}} + \mu_0 \epsilon_0 \frac{\partial \vec{\mathbf{E}}}{\partial t}
\end{aligned} \tag{13.3.1}$$

where ρ and $\vec{\mathbf{J}}$ are the free charge and the conduction current densities, respectively. In the absence of sources where $Q = 0$, $I = 0$, the above equations become

$$\begin{aligned}
\oiint_S \vec{\mathbf{E}} \cdot d\vec{\mathbf{A}} &= 0 \\
\oint \vec{\mathbf{E}} \cdot d\vec{\mathbf{s}} &= -\frac{d\Phi_B}{dt} \\
\oiint_S \vec{\mathbf{B}} \cdot d\vec{\mathbf{A}} &= 0 \\
\oint \vec{\mathbf{B}} \cdot d\vec{\mathbf{s}} &= \mu_0 \epsilon_0 \frac{d\Phi_E}{dt}
\end{aligned} \tag{13.3.2}$$

An important consequence of Maxwell's equations, as we shall see below, is the prediction of the existence of electromagnetic waves that travel with speed of light $c = 1/\sqrt{\mu_0 \epsilon_0}$. The reason is due to the fact that a changing electric field produces a magnetic field and vice versa, and the coupling between the two fields leads to the generation of electromagnetic waves. The prediction was confirmed by H. Hertz in 1887.

13.4 Plane Electromagnetic Waves

To examine the properties of the electromagnetic waves, let's consider for simplicity an electromagnetic wave propagating in the $+x$ -direction, with the electric field \vec{E} pointing in the $+y$ -direction and the magnetic field \vec{B} in the $+z$ -direction, as shown in Figure 13.4.1 below.

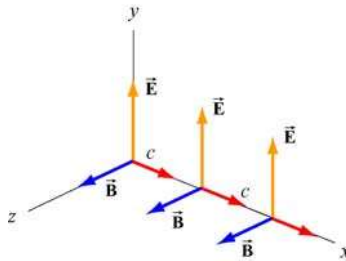

Figure 13.4.1 A plane electromagnetic wave

What we have here is an example of a plane wave since at any instant both \vec{E} and \vec{B} are uniform over any plane perpendicular to the direction of propagation. In addition, the wave is *transverse* because both fields are perpendicular to the direction of propagation, which points in the direction of the cross product $\vec{E} \times \vec{B}$.

Using Maxwell's equations, we may obtain the relationship between the magnitudes of the fields. To see this, consider a rectangular loop which lies in the xy plane, with the left side of the loop at x and the right at $x + \Delta x$. The bottom side of the loop is located at y , and the top side of the loop is located at $y + \Delta y$, as shown in Figure 13.4.2. Let the unit vector normal to the loop be in the positive z -direction, $\hat{n} = \hat{k}$.

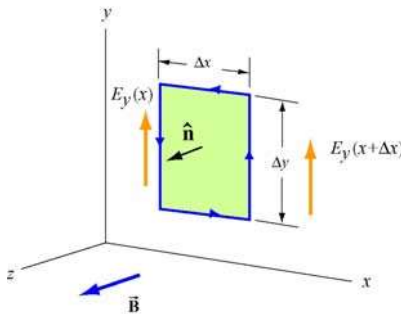

Figure 13.4.2 Spatial variation of the electric field \vec{E}

Using Faraday's law

$$\oint \vec{E} \cdot d\vec{s} = -\frac{d}{dt} \iint \vec{B} \cdot d\vec{A} \quad (13.4.1)$$

the left-hand-side can be written as

$$\oint \vec{\mathbf{E}} \cdot d\vec{\mathbf{s}} = E_y(x + \Delta x)\Delta y - E_y(x)\Delta y = [E_y(x + \Delta x) - E_y(x)]\Delta y = \frac{\partial E_y}{\partial x}(\Delta x \Delta y) \quad (13.4.2)$$

where we have made the expansion

$$E_y(x + \Delta x) = E_y(x) + \frac{\partial E_y}{\partial x} \Delta x + \dots \quad (13.4.3)$$

On the other hand, the rate of change of magnetic flux on the right-hand-side is given by

$$-\frac{d}{dt} \iint \vec{\mathbf{B}} \cdot d\vec{\mathbf{A}} = -\left(\frac{\partial B_z}{\partial t}\right)(\Delta x \Delta y) \quad (13.4.4)$$

Equating the two expressions and dividing through by the area $\Delta x \Delta y$ yields

$$\boxed{\frac{\partial E_y}{\partial x} = -\frac{\partial B_z}{\partial t}} \quad (13.4.5)$$

The second condition on the relationship between the electric and magnetic fields may be deduced by using the Ampere-Maxwell equation:

$$\oint \vec{\mathbf{B}} \cdot d\vec{\mathbf{s}} = \mu_0 \epsilon_0 \frac{d}{dt} \iint \vec{\mathbf{E}} \cdot d\vec{\mathbf{A}} \quad (13.4.6)$$

Consider a rectangular loop in the xz plane depicted in Figure 13.4.3, with a unit normal $\hat{\mathbf{n}} = \hat{\mathbf{j}}$.

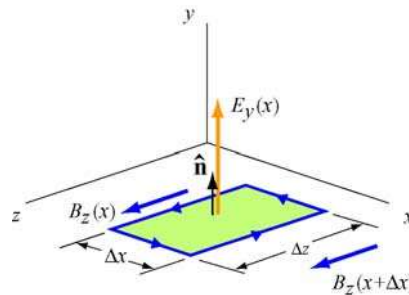

Figure 13.4.3 Spatial variation of the magnetic field $\vec{\mathbf{B}}$

The line integral of the magnetic field is

$$\begin{aligned}\oint \vec{\mathbf{B}} \cdot d\vec{\mathbf{s}} &= B_z(x)\Delta z - B_z(x+\Delta x)\Delta z = [B_z(x) - B_z(x+\Delta x)]\Delta z \\ &= -\left(\frac{\partial B_z}{\partial x}\right)(\Delta x \Delta z)\end{aligned}\quad (13.4.7)$$

On the other hand, the time derivative of the electric flux is

$$\mu_0 \epsilon_0 \frac{d}{dt} \iint \vec{\mathbf{E}} \cdot d\vec{\mathbf{A}} = \mu_0 \epsilon_0 \left(\frac{\partial E_y}{\partial t}\right)(\Delta x \Delta z) \quad (13.4.8)$$

Equating the two equations and dividing by $\Delta x \Delta z$, we have

$$-\frac{\partial B_z}{\partial x} = \mu_0 \epsilon_0 \left(\frac{\partial E_y}{\partial t}\right) \quad (13.4.9)$$

The result indicates that a time-varying electric field is generated by a spatially varying magnetic field.

Using Eqs. (13.4.4) and (13.4.8), one may verify that both the electric and magnetic fields satisfy the one-dimensional wave equation.

To show this, we first take another partial derivative of Eq. (13.4.5) with respect to x , and then another partial derivative of Eq. (13.4.9) with respect to t :

$$\frac{\partial^2 E_y}{\partial x^2} = -\frac{\partial}{\partial x} \left(\frac{\partial B_z}{\partial t}\right) = -\frac{\partial}{\partial t} \left(\frac{\partial B_z}{\partial x}\right) = -\frac{\partial}{\partial t} \left(-\mu_0 \epsilon_0 \frac{\partial E_y}{\partial t}\right) = \mu_0 \epsilon_0 \frac{\partial^2 E_y}{\partial t^2} \quad (13.4.10)$$

noting the interchangeability of the partial differentiations:

$$\frac{\partial}{\partial x} \left(\frac{\partial B_z}{\partial t}\right) = \frac{\partial}{\partial t} \left(\frac{\partial B_z}{\partial x}\right) \quad (13.4.11)$$

Similarly, taking another partial derivative of Eq. (13.4.9) with respect to x yields, and then another partial derivative of Eq. (13.4.5) with respect to t gives

$$\frac{\partial^2 B_z}{\partial x^2} = -\frac{\partial}{\partial x} \left(\mu_0 \epsilon_0 \frac{\partial E_y}{\partial t}\right) = -\mu_0 \epsilon_0 \frac{\partial}{\partial t} \left(\frac{\partial E_y}{\partial x}\right) = -\mu_0 \epsilon_0 \frac{\partial}{\partial t} \left(-\frac{\partial B_z}{\partial t}\right) = \mu_0 \epsilon_0 \frac{\partial^2 B_z}{\partial t^2} \quad (13.4.12)$$

The results may be summarized as:

$$\left(\frac{\partial^2}{\partial x^2} - \mu_0 \epsilon_0 \frac{\partial^2}{\partial t^2}\right) \begin{Bmatrix} E_y(x,t) \\ B_z(x,t) \end{Bmatrix} = 0 \quad (13.4.13)$$

Recall that the general form of a one-dimensional wave equation is given by

$$\left(\frac{\partial^2}{\partial x^2} - \frac{1}{v^2} \frac{\partial^2}{\partial t^2} \right) \psi(x, t) = 0 \quad (13.4.14)$$

where v is the speed of propagation and $\psi(x, t)$ is the wave function, we see clearly that both E_y and B_z satisfy the wave equation and propagate with the speed of light:

$$v = \frac{1}{\sqrt{\mu_0 \epsilon_0}} = \frac{1}{\sqrt{(4\pi \times 10^{-7} \text{ T} \cdot \text{m/A})(8.85 \times 10^{-12} \text{ C}^2/\text{N} \cdot \text{m}^2)}} = 2.997 \times 10^8 \text{ m/s} = c \quad (13.4.15)$$

Thus, we conclude that light is an electromagnetic wave. The spectrum of electromagnetic waves is shown in Figure 13.4.4.

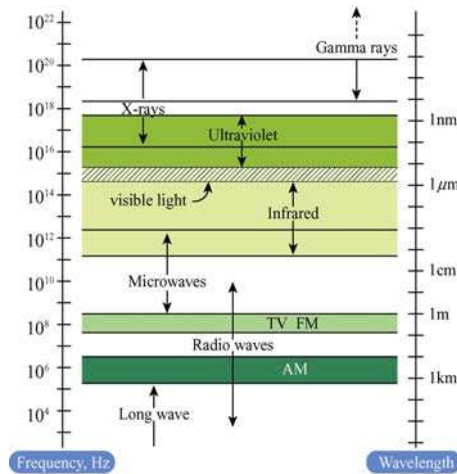

Figure 13.4.4 Electromagnetic spectrum

13.4.1 One-Dimensional Wave Equation

It is straightforward to verify that any function of the form $\psi(x \pm vt)$ satisfies the one-dimensional wave equation shown in Eq. (13.4.14). The proof proceeds as follows:

Let $x' = x \pm vt$ which yields $\partial x' / \partial x = 1$ and $\partial x' / \partial t = \pm v$. Using chain rule, the first two partial derivatives with respect to x are

$$\frac{\partial \psi(x')}{\partial x} = \frac{\partial \psi}{\partial x'} \frac{\partial x'}{\partial x} = \frac{\partial \psi}{\partial x'} \quad (13.4.16)$$

$$\frac{\partial^2 \psi}{\partial x^2} = \frac{\partial}{\partial x} \left(\frac{\partial \psi}{\partial x'} \right) = \frac{\partial^2 \psi}{\partial x'^2} \frac{\partial x'}{\partial x} = \frac{\partial^2 \psi}{\partial x'^2} \quad (13.4.17)$$

Similarly, the partial derivatives in t are given by

$$\frac{\partial \psi}{\partial t} = \frac{\partial \psi}{\partial x'} \frac{\partial x'}{\partial t} = \pm v \frac{\partial \psi}{\partial x'} \quad (13.4.18)$$

$$\frac{\partial^2 \psi}{\partial t^2} = \frac{\partial}{\partial t} \left(\pm v \frac{\partial \psi}{\partial x'} \right) = \pm v \frac{\partial^2 \psi}{\partial x'^2} \frac{\partial x'}{\partial t} = v^2 \frac{\partial^2 \psi}{\partial x'^2} \quad (13.4.19)$$

Comparing Eq. (13.4.17) with Eq. (13.4.19), we have

$$\frac{\partial^2 \psi}{\partial x'^2} = \frac{\partial^2 \psi}{\partial x^2} = \frac{1}{v^2} \frac{\partial^2 \psi}{\partial t^2} \quad (13.4.20)$$

which shows that $\psi(x \pm vt)$ satisfies the one-dimensional wave equation. The wave equation is an example of a linear differential equation, which means that if $\psi_1(x, t)$ and $\psi_2(x, t)$ are solutions to the wave equation, then $\psi_1(x, t) \pm \psi_2(x, t)$ is also a solution. The implication is that electromagnetic waves obey the superposition principle.

One possible solution to the wave equations is

$$\begin{aligned} \vec{\mathbf{E}} &= E_y(x, t) \hat{\mathbf{j}} = E_0 \cos k(x - vt) \hat{\mathbf{j}} = E_0 \cos(kx - \omega t) \hat{\mathbf{j}} \\ \vec{\mathbf{B}} &= B_z(x, t) \hat{\mathbf{k}} = B_0 \cos k(x - vt) \hat{\mathbf{k}} = B_0 \cos(kx - \omega t) \hat{\mathbf{k}} \end{aligned} \quad (13.4.21)$$

where the fields are sinusoidal, with amplitudes E_0 and B_0 . The angular wave number k is related to the wavelength λ by

$$k = \frac{2\pi}{\lambda} \quad (13.4.22)$$

and the angular frequency ω is

$$\omega = kv = 2\pi \frac{v}{\lambda} = 2\pi f \quad (13.4.23)$$

where f is the linear frequency. In empty space the wave propagates at the speed of light, $v = c$. The characteristic behavior of the sinusoidal electromagnetic wave is illustrated in Figure 13.4.5.

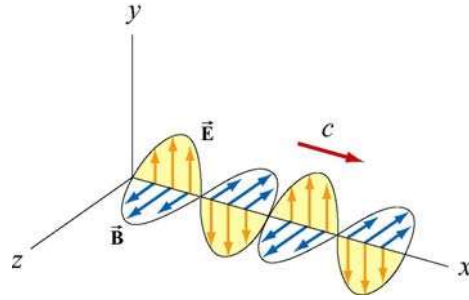

Figure 13.4.5 Plane electromagnetic wave propagating in the $+x$ direction.

We see that the \vec{E} and \vec{B} fields are always in phase (attaining maxima and minima at the same time.) To obtain the relationship between the field amplitudes E_0 and B_0 , we make use of Eqs. (13.4.4) and (13.4.8). Taking the partial derivatives leads to

$$\frac{\partial E_y}{\partial x} = -kE_0 \sin(kx - \omega t) \quad (13.4.24)$$

and

$$\frac{\partial B_z}{\partial t} = \omega B_0 \sin(kx - \omega t) \quad (13.4.25)$$

which implies $E_0 k = \omega B_0$, or

$$\boxed{\frac{E_0}{B_0} = \frac{\omega}{k} = c} \quad (13.4.26)$$

From Eqs. (13.4.20) and (13.4.21), one may easily show that the magnitudes of the fields at any instant are related by

$$\frac{E}{B} = c \quad (13.4.27)$$

Let us summarize the important features of electromagnetic waves described in Eq. (13.4.21):

1. The wave is transverse since both \vec{E} and \vec{B} fields are perpendicular to the direction of propagation, which points in the direction of the cross product $\vec{E} \times \vec{B}$.
2. The \vec{E} and \vec{B} fields are perpendicular to each other. Therefore, their dot product vanishes, $\vec{E} \cdot \vec{B} = 0$.

3. The ratio of the magnitudes and the amplitudes of the fields is

$$\frac{E}{B} = \frac{E_0}{B_0} = \frac{\omega}{k} = c$$

4. The speed of propagation in vacuum is equal to the speed of light, $c = 1/\sqrt{\mu_0\epsilon_0}$.

5. Electromagnetic waves obey the superposition principle.

13.5 Standing Electromagnetic Waves

Let us examine the situation where there are two sinusoidal plane electromagnetic waves, one traveling in the $+x$ -direction, with

$$E_{1y}(x, t) = E_{10} \cos(k_1x - \omega_1t), \quad B_{1z}(x, t) = B_{10} \cos(k_1x - \omega_1t) \quad (13.5.1)$$

and the other traveling in the $-x$ -direction, with

$$E_{2y}(x, t) = -E_{20} \cos(k_2x + \omega_2t), \quad B_{2z}(x, t) = B_{20} \cos(k_2x + \omega_2t) \quad (13.5.2)$$

For simplicity, we assume that these electromagnetic waves have the same amplitudes ($E_{10} = E_{20} = E_0$, $B_{10} = B_{20} = B_0$) and wavelengths ($k_1 = k_2 = k$, $\omega_1 = \omega_2 = \omega$). Using the superposition principle, the electric field and the magnetic fields can be written as

$$E_y(x, t) = E_{1y}(x, t) + E_{2y}(x, t) = E_0 [\cos(kx - \omega t) - \cos(kx + \omega t)] \quad (13.5.3)$$

and

$$B_z(x, t) = B_{1z}(x, t) + B_{2z}(x, t) = B_0 [\cos(kx - \omega t) + \cos(kx + \omega t)] \quad (13.5.4)$$

Using the identities

$$\cos(\alpha \pm \beta) = \cos \alpha \cos \beta \mp \sin \alpha \sin \beta \quad (13.5.5)$$

The above expressions may be rewritten as

$$\begin{aligned} E_y(x, t) &= E_0 [\cos kx \cos \omega t + \sin kx \sin \omega t - \cos kx \cos \omega t + \sin kx \sin \omega t] \\ &= 2E_0 \sin kx \sin \omega t \end{aligned} \quad (13.5.6)$$

and

$$\begin{aligned}
B_z(x,t) &= B_0 [\cos kx \cos \omega t + \sin kx \sin \omega t + \cos kx \cos \omega t - \sin kx \sin \omega t] \\
&= 2B_0 \cos kx \cos \omega t
\end{aligned} \tag{13.5.7}$$

One may verify that the total fields $E_y(x,t)$ and $B_z(x,t)$ still satisfy the wave equation stated in Eq. (13.4.13), even though they no longer have the form of functions of $kx \pm \omega t$. The waves described by Eqs. (13.5.6) and (13.5.7) are *standing waves*, which do not propagate but simply oscillate in space and time.

Let's first examine the spatial dependence of the fields. Eq. (13.5.6) shows that the total electric field remains zero at all times if $\sin kx = 0$, or

$$x = \frac{n\pi}{k} = \frac{n\pi}{2\pi/\lambda} = \frac{n\lambda}{2}, \quad n = 0, 1, 2, \dots \text{ (nodal planes of } \vec{\mathbf{E}}) \tag{13.5.8}$$

The planes that contain these points are called the *nodal planes* of the electric field. On the other hand, when $\sin kx = \pm 1$, or

$$x = \left(n + \frac{1}{2}\right) \frac{\pi}{k} = \left(n + \frac{1}{2}\right) \frac{\pi}{2\pi/\lambda} = \left(\frac{n}{2} + \frac{1}{4}\right) \lambda, \quad n = 0, 1, 2, \dots \text{ (anti-nodal planes of } \vec{\mathbf{E}}) \tag{13.5.9}$$

the amplitude of the field is at its maximum $2E_0$. The planes that contain these points are the *anti-nodal planes* of the electric field. Note that in between two nodal planes, there is an anti-nodal plane, and vice versa.

For the magnetic field, the nodal planes must contain points which meets the condition $\cos kx = 0$. This yields

$$x = \left(n + \frac{1}{2}\right) \frac{\pi}{k} = \left(\frac{n}{2} + \frac{1}{4}\right) \lambda, \quad n = 0, 1, 2, \dots \text{ (nodal planes of } \vec{\mathbf{B}}) \tag{13.5.10}$$

Similarly, the anti-nodal planes for $\vec{\mathbf{B}}$ contain points that satisfy $\cos kx = \pm 1$, or

$$x = \frac{n\pi}{k} = \frac{n\pi}{2\pi/\lambda} = \frac{n\lambda}{2}, \quad n = 0, 1, 2, \dots \text{ (anti-nodal planes of } \vec{\mathbf{B}}) \tag{13.5.11}$$

Thus, we see that a nodal plane of $\vec{\mathbf{E}}$ corresponds to an anti-nodal plane of $\vec{\mathbf{B}}$, and vice versa.

For the time dependence, Eq. (13.5.6) shows that the electric field is zero everywhere when $\sin \omega t = 0$, or

$$t = \frac{n\pi}{\omega} = \frac{n\pi}{2\pi/T} = \frac{nT}{2}, \quad n = 0, 1, 2, \dots \quad (13.5.12)$$

where $T = 1/f = 2\pi/\omega$ is the period. However, this is precisely the maximum condition for the magnetic field. Thus, unlike the traveling electromagnetic wave in which the electric and the magnetic fields are always in phase, in standing electromagnetic waves, the two fields are 90° out of phase.

Standing electromagnetic waves can be formed by confining the electromagnetic waves within two perfectly reflecting conductors, as shown in Figure 13.4.6.

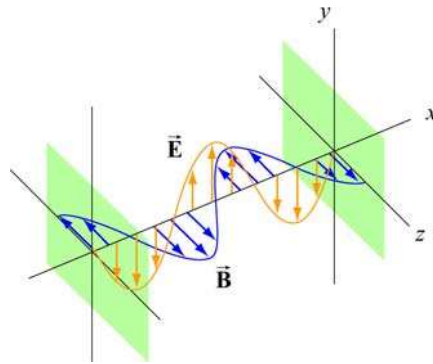

Figure 13.4.6 Formation of standing electromagnetic waves using two perfectly reflecting conductors.

13.6 Poynting Vector

In Chapters 5 and 11 we had seen that electric and magnetic fields store energy. Thus, energy can also be carried by the electromagnetic waves which consist of both fields. Consider a plane electromagnetic wave passing through a small volume element of area A and thickness dx , as shown in Figure 13.6.1.

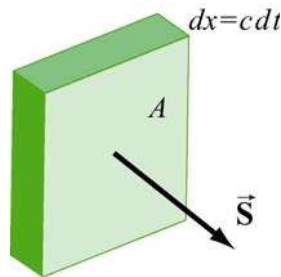

Figure 13.6.1 Electromagnetic wave passing through a volume element

The total energy in the volume element is given by

$$dU = uA dx = (u_E + u_B)A dx = \frac{1}{2} \left(\varepsilon_0 E^2 + \frac{B^2}{\mu_0} \right) A dx \quad (13.6.1)$$

where

$$u_E = \frac{1}{2} \varepsilon_0 E^2, \quad u_B = \frac{B^2}{2\mu_0} \quad (13.6.2)$$

are the energy densities associated with the electric and magnetic fields. Since the electromagnetic wave propagates with the speed of light c , the amount of time it takes for the wave to move through the volume element is $dt = dx/c$. Thus, one may obtain the rate of change of energy per unit area, denoted with the symbol S , as

$$S = \frac{dU}{A dt} = \frac{c}{2} \left(\varepsilon_0 E^2 + \frac{B^2}{\mu_0} \right) \quad (13.6.3)$$

The SI unit of S is W/m^2 . Noting that $E = cB$ and $c = 1/\sqrt{\mu_0 \varepsilon_0}$, the above expression may be rewritten as

$$S = \frac{c}{2} \left(\varepsilon_0 E^2 + \frac{B^2}{\mu_0} \right) = \frac{cB^2}{\mu_0} = c\varepsilon_0 E^2 = \frac{EB}{\mu_0} \quad (13.6.4)$$

In general, the rate of the energy flow per unit area may be described by the Poynting vector \vec{S} (after the British physicist John Poynting), which is defined as

$$\vec{S} = \frac{1}{\mu_0} \vec{E} \times \vec{B} \quad (13.6.5)$$

with \vec{S} pointing in the direction of propagation. Since the fields \vec{E} and \vec{B} are perpendicular, we may readily verify that the magnitude of \vec{S} is

$$|\vec{S}| = \frac{|\vec{E} \times \vec{B}|}{\mu_0} = \frac{EB}{\mu_0} = S \quad (13.6.6)$$

As an example, suppose the electric component of the plane electromagnetic wave is $\vec{E} = E_0 \cos(kx - \omega t) \hat{\mathbf{j}}$. The corresponding magnetic component is $\vec{B} = B_0 \cos(kx - \omega t) \hat{\mathbf{k}}$, and the direction of propagation is $+x$. The Poynting vector can be obtained as

$$\vec{S} = \frac{1}{\mu_0} \left(E_0 \cos(kx - \omega t) \hat{\mathbf{j}} \right) \times \left(B_0 \cos(kx - \omega t) \hat{\mathbf{k}} \right) = \frac{E_0 B_0}{\mu_0} \cos^2(kx - \omega t) \hat{\mathbf{i}} \quad (13.6.7)$$

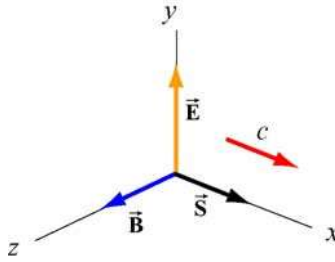

Figure 13.6.2 Poynting vector for a plane wave

As expected, \vec{S} points in the direction of wave propagation (see Figure 13.6.2).

The intensity of the wave, I , defined as the time average of S , is given by

$$I = \langle S \rangle = \frac{E_0 B_0}{\mu_0} \langle \cos^2(kx - \omega t) \rangle = \frac{E_0 B_0}{2\mu_0} = \frac{E_0^2}{2c\mu_0} = \frac{cB_0^2}{2\mu_0} \quad (13.6.8)$$

where we have used

$$\langle \cos^2(kx - \omega t) \rangle = \frac{1}{2} \quad (13.6.9)$$

To relate intensity to the energy density, we first note the equality between the electric and the magnetic energy densities:

$$u_B = \frac{B^2}{2\mu_0} = \frac{(E/c)^2}{2\mu_0} = \frac{E^2}{2c^2\mu_0} = \frac{\epsilon_0 E^2}{2} = u_E \quad (13.6.10)$$

The average total energy density then becomes

$$\begin{aligned} \langle u \rangle &= \langle u_E + u_B \rangle = \epsilon_0 \langle E^2 \rangle = \frac{\epsilon_0}{2} E_0^2 \\ &= \frac{1}{\mu_0} \langle B^2 \rangle = \frac{B_0^2}{2\mu_0} \end{aligned} \quad (13.6.11)$$

Thus, the intensity is related to the average energy density by

$$I = \langle S \rangle = c \langle u \rangle \quad (13.6.12)$$

Example 13.1: Solar Constant

At the upper surface of the Earth's atmosphere, the time-averaged magnitude of the Poynting vector, $\langle S \rangle = 1.35 \times 10^3 \text{ W/m}^2$, is referred to as the *solar constant*.

(a) Assuming that the Sun's electromagnetic radiation is a plane sinusoidal wave, what are the magnitudes of the electric and magnetic fields?

(b) What is the total time-averaged power radiated by the Sun? The mean Sun-Earth distance is $R = 1.50 \times 10^{11} \text{ m}$.

Solution:

(a) The time-averaged Poynting vector is related to the amplitude of the electric field by

$$\langle S \rangle = \frac{c}{2} \epsilon_0 E_0^2.$$

Thus, the amplitude of the electric field is

$$E_0 = \sqrt{\frac{2\langle S \rangle}{c\epsilon_0}} = \sqrt{\frac{2(1.35 \times 10^3 \text{ W/m}^2)}{(3.0 \times 10^8 \text{ m/s})(8.85 \times 10^{-12} \text{ C}^2/\text{N} \cdot \text{m}^2)}} = 1.01 \times 10^3 \text{ V/m}.$$

The corresponding amplitude of the magnetic field is

$$B_0 = \frac{E_0}{c} = \frac{1.01 \times 10^3 \text{ V/m}}{3.0 \times 10^8 \text{ m/s}} = 3.4 \times 10^{-6} \text{ T}.$$

Note that the associated magnetic field is less than one-tenth the Earth's magnetic field.

(b) The total time averaged power radiated by the Sun at the distance R is

$$\langle P \rangle = \langle S \rangle A = \langle S \rangle 4\pi R^2 = (1.35 \times 10^3 \text{ W/m}^2) 4\pi (1.50 \times 10^{11} \text{ m})^2 = 3.8 \times 10^{26} \text{ W}$$

The type of wave discussed in the example above is a spherical wave (Figure 13.6.3a), which originates from a "point-like" source. The intensity at a distance r from the source is

$$I = \langle S \rangle = \frac{\langle P \rangle}{4\pi r^2} \quad (13.6.13)$$

which decreases as $1/r^2$. On the other hand, the intensity of a plane wave (Figure 13.6.3b) remains constant and there is no spreading in its energy.

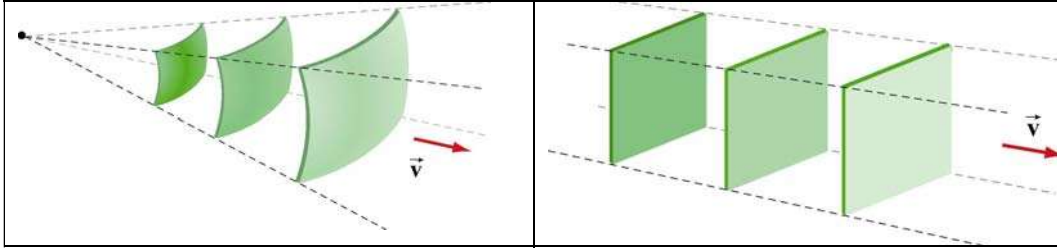

Figure 13.6.3 (a) a spherical wave, and (b) plane wave.

Example 13.2: Intensity of a Standing Wave

Compute the intensity of the standing electromagnetic wave given by

$$E_y(x, t) = 2E_0 \cos kx \cos \omega t, \quad B_z(x, t) = 2B_0 \sin kx \sin \omega t$$

Solution:

The Poynting vector for the standing wave is

$$\begin{aligned} \vec{S} &= \frac{\vec{E} \times \vec{B}}{\mu_0} = \frac{1}{\mu_0} (2E_0 \cos kx \cos \omega t \hat{j}) \times (2B_0 \sin kx \sin \omega t \hat{k}) \\ &= \frac{4E_0 B_0}{\mu_0} (\sin kx \cos kx \sin \omega t \cos \omega t) \hat{i} \\ &= \frac{E_0 B_0}{\mu_0} (\sin 2kx \sin 2\omega t) \hat{i} \end{aligned} \quad (13.6.14)$$

The time average of S is

$$\langle S \rangle = \frac{E_0 B_0}{\mu_0} \sin 2kx \langle \sin 2\omega t \rangle = 0 \quad (13.6.15)$$

The result is to be expected since the standing wave does not propagate. Alternatively, we may say that the energy carried by the two waves traveling in the opposite directions to form the standing wave exactly cancel each other, with no net energy transfer.

13.6.1 Energy Transport

Since the Poynting vector \vec{S} represents the rate of the energy flow per unit area, the rate of change of energy in a system can be written as

$$\boxed{\frac{dU}{dt} = -\oiint \vec{S} \cdot d\vec{A}} \quad (13.6.16)$$

where $d\vec{A} = dA \hat{n}$, where \hat{n} is a unit vector in the *outward* normal direction. The above expression allows us to interpret \vec{S} as the energy flux density, in analogy to the current density \vec{J} in

$$I = \frac{dQ}{dt} = \iint \vec{J} \cdot d\vec{A} \quad (13.6.17)$$

If energy flows out of the system, then $\vec{S} = S \hat{n}$ and $dU/dt < 0$, showing an overall decrease of energy in the system. On the other hand, if energy flows into the system, then $\vec{S} = S(-\hat{n})$ and $dU/dt > 0$, indicating an overall increase of energy.

As an example to elucidate the physical meaning of the above equation, let's consider an inductor made up of a section of a very long air-core solenoid of length l , radius r and n turns per unit length. Suppose at some instant the current is changing at a rate $dI/dt > 0$. Using Ampere's law, the magnetic field in the solenoid is

$$\oint_C \vec{B} \cdot d\vec{s} = Bl = \mu_0(NI)$$

or

$$\vec{B} = \mu_0 n I \hat{k} \quad (13.6.18)$$

Thus, the rate of increase of the magnetic field is

$$\frac{dB}{dt} = \mu_0 n \frac{dI}{dt} \quad (13.6.19)$$

According to Faraday's law:

$$\varepsilon = \oint_C \vec{E} \cdot d\vec{s} = -\frac{d\Phi_B}{dt} \quad (13.6.20)$$

changing magnetic flux results in an induced electric field., which is given by

$$E(2\pi r) = -\mu_0 n \left(\frac{dI}{dt} \right) \pi r^2$$

or

$$\vec{E} = -\frac{\mu_0 n r}{2} \left(\frac{dI}{dt} \right) \hat{\phi} \quad (13.6.21)$$

The direction of \vec{E} is clockwise, the same as the induced current, as shown in Figure 13.6.4.

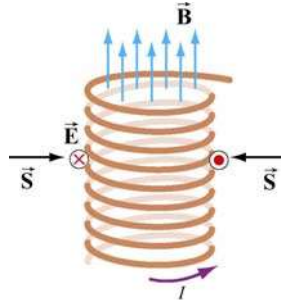

Figure 13.6.4 Poynting vector for a solenoid with $dI/dt > 0$

The corresponding Poynting vector can then be obtained as

$$\vec{S} = \frac{\vec{E} \times \vec{B}}{\mu_0} = \frac{1}{\mu_0} \left[-\frac{\mu_0 n r}{2} \left(\frac{dI}{dt} \right) \hat{\phi} \right] \times (\mu_0 n I \hat{k}) = -\frac{\mu_0 n^2 r I}{2} \left(\frac{dI}{dt} \right) \hat{r} \quad (13.6.22)$$

which points radially inward, i.e., along the $-\hat{r}$ direction. The directions of the fields and the Poynting vector are shown in Figure 13.6.4.

Since the magnetic energy stored in the inductor is

$$U_B = \left(\frac{B^2}{2\mu_0} \right) (\pi r^2 l) = \frac{1}{2} \mu_0 \pi n^2 I^2 r^2 l \quad (13.6.23)$$

the rate of change of U_B is

$$P = \frac{dU_B}{dt} = \mu_0 \pi n^2 I r^2 l \left(\frac{dI}{dt} \right) = I |\varepsilon| \quad (13.6.24)$$

where

$$\varepsilon = -N \frac{d\Phi_B}{dt} = -(nl) \left(\frac{dB}{dt} \right) \pi r^2 = -\mu_0 n^2 l \pi r^2 \left(\frac{dI}{dt} \right) \quad (13.6.25)$$

is the induced emf. One may readily verify that this is the same as

$$-\oint \vec{S} \cdot d\vec{A} = \frac{\mu_0 n^2 r I}{2} \left(\frac{dI}{dt} \right) \cdot (2\pi r l) = \mu_0 \pi n^2 I r^2 l \left(\frac{dI}{dt} \right) \quad (13.6.26)$$

Thus, we have

$$\frac{dU_B}{dt} = -\oint \vec{S} \cdot d\vec{A} > 0 \quad (13.6.27)$$

The energy in the system is increased, as expected when $dI/dt > 0$. On the other hand, if $dI/dt < 0$, the energy of the system would decrease, with $dU_B/dt < 0$.

13.7 Momentum and Radiation Pressure

The electromagnetic wave transports not only energy but also momentum, and hence can exert a *radiation pressure* on a surface due to the absorption and reflection of the momentum. Maxwell showed that if the plane electromagnetic wave is completely absorbed by a surface, the momentum transferred is related to the energy absorbed by

$$\Delta p = \frac{\Delta U}{c} \quad (\text{complete absorption}) \quad (13.7.1)$$

On the other hand, if the electromagnetic wave is completely reflected by a surface such as a mirror, the result becomes

$$\Delta p = \frac{2\Delta U}{c} \quad (\text{complete reflection}) \quad (13.7.2)$$

For the complete absorption case, the average radiation pressure (force per unit area) is given by

$$P = \frac{\langle F \rangle}{A} = \frac{1}{A} \left\langle \frac{dp}{dt} \right\rangle = \frac{1}{Ac} \left\langle \frac{dU}{dt} \right\rangle \quad (13.7.3)$$

Since the rate of energy delivered to the surface is

$$\left\langle \frac{dU}{dt} \right\rangle = \langle S \rangle A = IA$$

we arrive at

$$P = \frac{I}{c} \quad (\text{complete absorption}) \quad (13.7.4)$$

Similarly, if the radiation is completely reflected, the radiation pressure is twice as great as the case of complete absorption:

$$P = \frac{2I}{c} \quad (\text{complete reflection}) \quad (13.7.5)$$

13.8 Production of Electromagnetic Waves

Electromagnetic waves are produced when electric charges are accelerated. In other words, a charge must radiate energy when it undergoes acceleration. Radiation cannot be produced by stationary charges or steady currents. Figure 13.8.1 depicts the electric field lines produced by an oscillating charge at some instant.

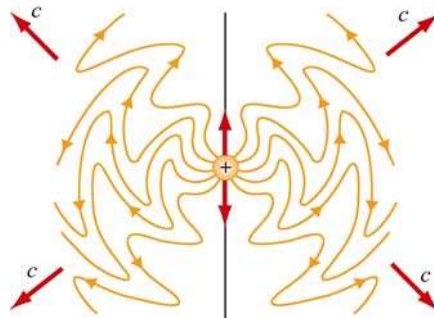

Figure 13.8.1 Electric field lines of an oscillating point charge

A common way of producing electromagnetic waves is to apply a sinusoidal voltage source to an antenna, causing the charges to accumulate near the tips of the antenna. The effect is to produce an oscillating electric dipole. The production of electric-dipole radiation is depicted in Figure 13.8.2.

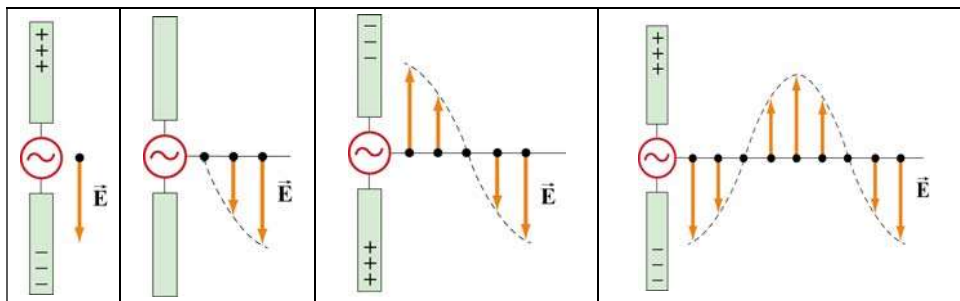

Figure 13.8.2 Electric fields produced by an electric-dipole antenna.

At time $t=0$ the ends of the rods are charged so that the upper rod has a maximum positive charge and the lower rod has an equal amount of negative charge. At this instant the electric field near the antenna points downward. The charges then begin to decrease. After one-fourth period, $t=T/4$, the charges vanish momentarily and the electric field strength is zero. Subsequently, the polarities of the rods are reversed with negative charges continuing to accumulate on the upper rod and positive charges on the lower until $t=T/2$, when the maximum is attained. At this moment, the electric field near the rod points upward. As the charges continue to oscillate between the rods, electric fields are produced and move away with speed of light. The motion of the charges also produces a current which in turn sets up a magnetic field encircling the rods. However, the behavior

of the fields near the antenna is expected to be very different from that far away from the antenna.

Let us consider a half-wavelength antenna, in which the length of each rod is equal to one quarter of the wavelength of the emitted radiation. Since charges are driven to oscillate back and forth between the rods by the alternating voltage, the antenna may be approximated as an oscillating electric dipole. Figure 13.8.3 depicts the electric and the magnetic field lines at the instant the current is upward. Notice that the Poynting vectors at the positions shown are directed outward.

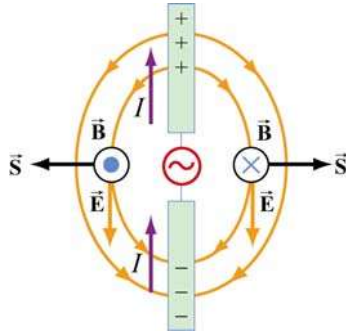

Figure 13.8.3 Electric and magnetic field lines produced by an electric-dipole antenna.

In general, the radiation pattern produced is very complex. However, at a distance which is much greater than the dimensions of the system and the wavelength of the radiation, the fields exhibit a very different behavior. In this “far region,” the radiation is caused by the continuous induction of a magnetic field due to a time-varying electric field and vice versa. Both fields oscillate in phase and vary in amplitude as $1/r$.

The intensity of the variation can be shown to vary as $\sin^2 \theta / r^2$, where θ is the angle measured from the axis of the antenna. The angular dependence of the intensity $I(\theta)$ is shown in Figure 13.8.4. From the figure, we see that the intensity is a maximum in a plane which passes through the midpoint of the antenna and is perpendicular to it.

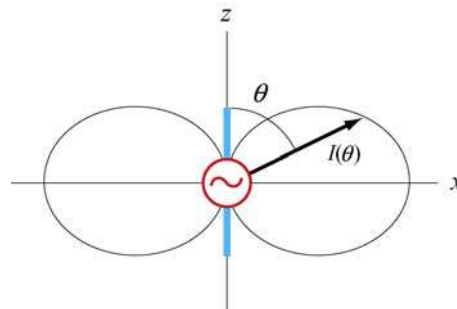

Figure 13.8.4 Angular dependence of the radiation intensity.

Animation 13.1: Electric Dipole Radiation 1

Consider an electric dipole whose dipole moment varies in time according to

$$\vec{p}(t) = p_0 \left[1 + \frac{1}{10} \cos\left(\frac{2\pi t}{T}\right) \right] \hat{\mathbf{k}} \quad (13.8.1)$$

Figure 13.8.5 shows one frame of an animation of these fields. Close to the dipole, the field line motion and thus the Poynting vector is first outward and then inward, corresponding to energy flow outward as the quasi-static dipolar electric field energy is being built up, and energy flow inward as the quasi-static dipole electric field energy is being destroyed.

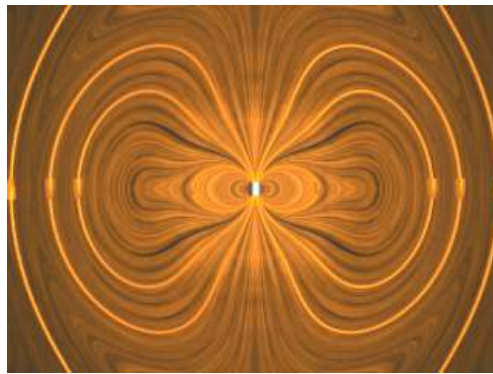

Figure 13.8.5 Radiation from an electric dipole whose dipole moment varies by 10%.

Even though the energy flow direction changes sign in these regions, there is still a small time-averaged energy flow outward. This small energy flow outward represents the small amount of energy radiated away to infinity. Outside of the point at which the outer field lines detach from the dipole and move off to infinity, the velocity of the field lines, and thus the direction of the electromagnetic energy flow, is always outward. This is the region dominated by radiation fields, which consistently carry energy outward to infinity.

Animation 13.2: Electric Dipole Radiation 2

Figure 13.8.6 shows one frame of an animation of an electric dipole characterized by

$$\vec{p}(t) = p_0 \cos\left(\frac{2\pi t}{T}\right) \hat{\mathbf{k}} \quad (13.8.2)$$

The equation shows that the direction of the dipole moment varies between $+\hat{\mathbf{k}}$ and $-\hat{\mathbf{k}}$.

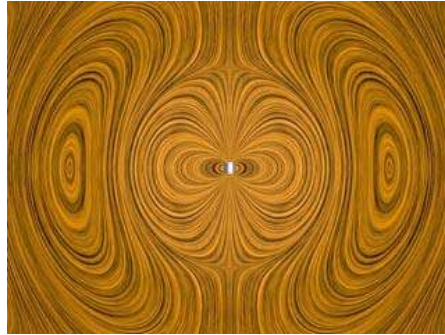

Figure 13.8.6 Radiation from an electric dipole whose dipole moment completely reverses with time.

Animation 13.3: Radiation From a Quarter-Wave Antenna

Figure 13.8.7(a) shows the radiation pattern at one instant of time from a quarter-wave antenna. Figure 13.8.7(b) shows this radiation pattern in a plane over the full period of the radiation. A quarter-wave antenna produces radiation whose wavelength is twice the tip to tip length of the antenna. This is evident in the animation of Figure 13.8.7(b).

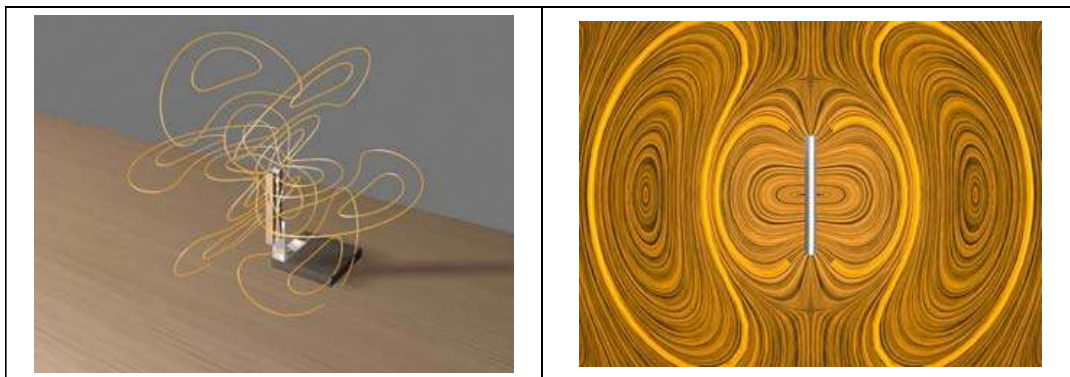

Figure 13.8.7 Radiation pattern from a quarter-wave antenna: (a) The azimuthal pattern at one instant of time, and (b) the radiation pattern in one plane over the full period.

13.8.1 Plane Waves

We have seen that electromagnetic plane waves propagate in empty space at the speed of light. Below we demonstrate how one would create such waves in a particularly simple planar geometry. Although physically this is not particularly applicable to the real world, it is reasonably easy to treat, and we can see directly how electromagnetic plane waves are generated, *why it takes work to make them*, and how much energy they carry away with them.

To make an electromagnetic plane wave, we do much the same thing we do when we make waves on a string. We grab the string somewhere and shake it, and thereby

generate a wave on the string. We do work against the tension in the string when we shake it, and that work is carried off as an energy flux in the wave. Electromagnetic waves are much the same proposition. The electric field line serves as the “string.” As we will see below, there is a tension associated with an electric field line, in that when we shake it (try to displace it from its initial position), there is a restoring force that resists the shake, and a wave propagates along the field line as a result of the shake. To understand in detail what happens in this process will involve using most of the electromagnetism we have learned thus far, from Gauss's law to Ampere's law plus the reasonable assumption that electromagnetic information propagates at speed c in a vacuum.

How do we shake an electric field line, and what do we grab on to? What we do is shake the electric charges that the field lines are attached to. After all, it is these charges that produce the electric field, and in a very real sense the electric field is "rooted" in the electric charges that produce them. Knowing this, and assuming that in a vacuum, electromagnetic signals propagate at the speed of light, we can pretty much puzzle out how to make a plane electromagnetic wave by shaking charges. Let's first figure out how to make a *kink* in an electric field line, and then we'll go on to make sinusoidal waves.

Suppose we have an infinite sheet of charge located in the yz -plane, initially at rest, with surface charge density σ , as shown in Figure 13.8.8.

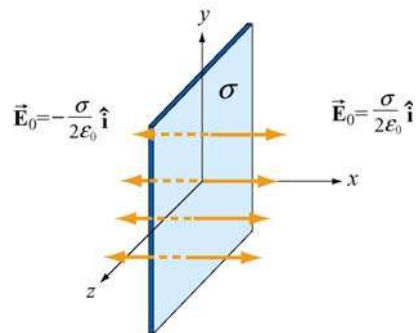

Figure 13.8.8 Electric field due to an infinite sheet with charge density σ .

From Gauss's law discussed in Chapter 4, we know that this surface charge will give rise to a static electric field $\vec{\mathbf{E}}_0$:

$$\vec{\mathbf{E}}_0 = \begin{cases} +(\sigma/2\epsilon_0)\hat{\mathbf{i}}, & x > 0 \\ -(\sigma/2\epsilon_0)\hat{\mathbf{i}}, & x < 0 \end{cases} \quad (13.8.3)$$

Now, at $t=0$, we grab the sheet of charge and start pulling it *downward* with *constant* velocity $\vec{\mathbf{v}} = -v\hat{\mathbf{j}}$. Let's examine how things will then appear at a later time $t=T$. In particular, before the sheet starts moving, let's look at the field line that goes through $y=0$ for $t < 0$, as shown in Figure 13.8.9(a).

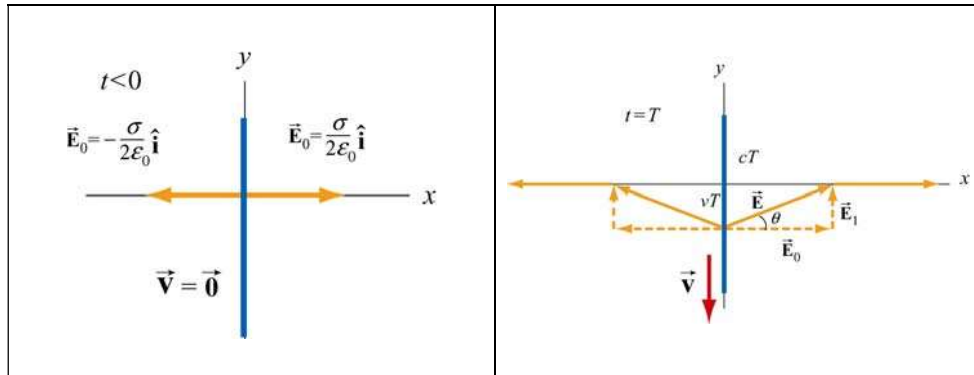

Figure 13.8.9 Electric field lines (a) through $y=0$ at $t < 0$, and (b) at $t = T$.

The “foot” of this electric field line, that is, where it is anchored, is rooted in the electric charge that generates it, and that “foot” must move downward with the sheet of charge, at the same speed as the charges move downward. Thus the “foot” of our electric field line, which was initially at $y=0$ at $t=0$, will have moved a distance $y = -vT$ down the y -axis at time $t = T$.

We have assumed that the information that this field line is being dragged downward will propagate outward from $x=0$ at the speed of light c . Thus the portion of our field line located a distance $x > cT$ along the x -axis from the origin doesn't know the charges are moving, and thus has not yet begun to move downward. Our field line therefore must appear at time $t = T$ as shown in Figure 13.8.9(b). Nothing has happened outside of $|x| > cT$; the foot of the field line at $x=0$ is a distance $y = -vT$ down the y -axis, and we have guessed about what the field line must look like for $0 < |x| < cT$ by simply connecting the two positions on the field line that we know about at time T ($x=0$ and $|x|=cT$) by a straight line. This is exactly the guess we would make if we were dealing with a string instead of an electric field. This is a reasonable thing to do, and it turns out to be the right guess.

What we have done by pulling down on the charged sheet is to generate a perturbation in the electric field, \vec{E}_1 in addition to the static field \vec{E}_0 . Thus, the total field \vec{E} for $0 < |x| < cT$ is

$$\vec{E} = \vec{E}_0 + \vec{E}_1 \quad (13.8.4)$$

As shown in Figure 13.8.9(b), the field vector \vec{E} must be parallel to the line connecting the foot of the field line and the position of the field line at $|x|=cT$. This implies

$$\tan \theta = \frac{E_1}{E_0} = \frac{vT}{cT} = \frac{v}{c} \quad (13.8.5)$$

where $E_1 = |\vec{\mathbf{E}}_1|$ and $E_0 = |\vec{\mathbf{E}}_0|$ are the magnitudes of the fields, and θ is the angle with the x -axis. Using Eq. (13.8.5), the perturbation field can be written as

$$\vec{\mathbf{E}}_1 = \left(\frac{v}{c} E_0 \right) \hat{\mathbf{j}} = \left(\frac{v\sigma}{2\epsilon_0 c} \right) \hat{\mathbf{j}} \quad (13.8.6)$$

where we have used $E_0 = \sigma/2\epsilon_0$. We have generated an electric field perturbation, and this expression tells us how large the perturbation field $\vec{\mathbf{E}}_1$ is for a given speed of the sheet of charge, v .

This explains why the electric field line has a *tension* associated with it, just as a string does. The direction of $\vec{\mathbf{E}}_1$ is such that the forces it exerts on the charges in the sheet *resist* the motion of the sheet. That is, there is an *upward* electric force on the sheet when we try to move it *downward*. For an infinitesimal area dA of the sheet containing charge $dq = \sigma dA$, the upward “tension” associated with the electric field is

$$d\vec{\mathbf{F}}_e = dq\vec{\mathbf{E}}_1 = (\sigma dA) \left(\frac{v\sigma}{2\epsilon_0 c} \right) \hat{\mathbf{j}} = \left(\frac{v\sigma^2 dA}{2\epsilon_0 c} \right) \hat{\mathbf{j}} \quad (13.8.7)$$

Therefore, to overcome the tension, the external agent must apply an equal but opposite (*downward*) force

$$d\vec{\mathbf{F}}_{\text{ext}} = -d\vec{\mathbf{F}}_e = - \left(\frac{v\sigma^2 dA}{2\epsilon_0 c} \right) \hat{\mathbf{j}} \quad (13.8.8)$$

Since the amount of work done is $dW_{\text{ext}} = \vec{\mathbf{F}}_{\text{ext}} \cdot d\vec{\mathbf{s}}$, the work done per unit time per unit area by the external agent is

$$\frac{d^2 W_{\text{ext}}}{dA dt} = \frac{d\vec{\mathbf{F}}_{\text{ext}}}{dA} \cdot \frac{d\vec{\mathbf{s}}}{dt} = \left(-\frac{v\sigma^2}{2\epsilon_0 c} \hat{\mathbf{j}} \right) \cdot (-v \hat{\mathbf{j}}) = \frac{v^2 \sigma^2}{2\epsilon_0 c} \quad (13.8.9)$$

What else has happened in this process of moving the charged sheet down? Well, once the charged sheet is in motion, we have created a sheet of current with surface current density (current per unit length) $\vec{\mathbf{K}} = -\sigma v \hat{\mathbf{j}}$. From Ampere's law, we know that a *magnetic field* has been created, in addition to $\vec{\mathbf{E}}_1$. The current sheet will produce a magnetic field (see Example 9.4)

$$\vec{\mathbf{B}}_1 = \begin{cases} +(\mu_0 \sigma v / 2) \hat{\mathbf{k}}, & x > 0 \\ -(\mu_0 \sigma v / 2) \hat{\mathbf{k}}, & x < 0 \end{cases} \quad (13.8.10)$$

This magnetic field changes direction as we move from negative to positive values of x , (across the current sheet). The configuration of the field due to a downward current is shown in Figure 13.8.10 for $|x| < cT$. Again, the information that the charged sheet has started moving, producing a current sheet and associated magnetic field, can only propagate outward from $x = 0$ at the speed of light c . Therefore the magnetic field is still zero, $\vec{\mathbf{B}} = \vec{\mathbf{0}}$ for $|x| > cT$. Note that

$$\frac{E_1}{B_1} = \frac{v\sigma/2\epsilon_0 c}{\mu_0\sigma v/2} = \frac{1}{c\mu_0\epsilon_0} = c \quad (13.8.11)$$

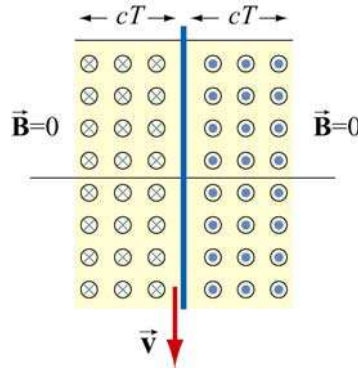

Figure 13.8.10 Magnetic field at $t = T$.

The magnetic field $\vec{\mathbf{B}}_1$ generated by the current sheet is perpendicular to $\vec{\mathbf{E}}_1$ with a magnitude $B_1 = E_1/c$, as expected for a transverse electromagnetic wave.

Now, let's discuss the energy carried away by these perturbation fields. The energy flux associated with an electromagnetic field is given by the Poynting vector $\vec{\mathbf{S}}$. For $x > 0$, the energy flowing to the *right* is

$$\vec{\mathbf{S}} = \frac{1}{\mu_0} \vec{\mathbf{E}}_1 \times \vec{\mathbf{B}}_1 = \frac{1}{\mu_0} \left(\frac{v\sigma}{2\epsilon_0 c} \hat{\mathbf{j}} \right) \times \left(\frac{\mu_0\sigma v}{2} \hat{\mathbf{k}} \right) = \left(\frac{v^2\sigma^2}{4\epsilon_0 c} \right) \hat{\mathbf{i}} \quad (13.8.12)$$

This is only half of the work we do per unit time per unit area to pull the sheet down, as given by Eq. (13.8.9). Since the fields on the left carry exactly the same amount of energy flux *to the left*, (the magnetic field $\vec{\mathbf{B}}_1$ changes direction across the plane $x = 0$ whereas the electric field $\vec{\mathbf{E}}_1$ does not, so the Poynting flux also changes across $x = 0$). So the total energy flux carried off by the perturbation electric and magnetic fields we have generated is *exactly equal* to the rate of work per unit area to pull the charged sheet down against the tension in the electric field. Thus we have generated perturbation electromagnetic fields that carry off energy at exactly the rate that it takes to create them.

Where does the energy carried off by the electromagnetic wave come from? The external agent who originally “shook” the charge to produce the wave had to do work against the perturbation electric field the shaking produces, and that agent is the ultimate source of the energy carried by the wave. An exactly analogous situation exists when one asks where the energy carried by a wave on a string comes from. The agent who originally shook the string to produce the wave had to do work to shake it against the restoring tension in the string, and that agent is the ultimate source of energy carried by a wave on a string.

13.8.2 Sinusoidal Electromagnetic Wave

How about generating a sinusoidal wave with angular frequency ω ? To do this, instead of pulling the charge sheet down at constant speed, we just shake it up and down with a velocity $\vec{v}(t) = -v_0 \cos \omega t \hat{\mathbf{j}}$. The oscillating sheet of charge will generate fields which are given by:

$$\vec{\mathbf{E}}_1 = \frac{c\mu_0\sigma v_0}{2} \cos \omega \left(t - \frac{x}{c} \right) \hat{\mathbf{j}}, \quad \vec{\mathbf{B}}_1 = \frac{\mu_0\sigma v_0}{2} \cos \omega \left(t - \frac{x}{c} \right) \hat{\mathbf{k}} \quad (13.8.13)$$

for $x > 0$ and, for $x < 0$,

$$\vec{\mathbf{E}}_1 = \frac{c\mu_0\sigma v_0}{2} \cos \omega \left(t + \frac{x}{c} \right) \hat{\mathbf{j}}, \quad \vec{\mathbf{B}}_1 = -\frac{\mu_0\sigma v_0}{2} \cos \omega \left(t + \frac{x}{c} \right) \hat{\mathbf{k}} \quad (13.8.14)$$

In Eqs. (13.8.13) and (13.8.14) we have chosen the *amplitudes* of these terms to be the amplitudes of the kink generated above for constant speed of the sheet, with $E_1 / B_1 = c$, but now allowing for the fact that the speed is varying sinusoidally in time with frequency ω . But why have we put the $(t - x/c)$ and $(t + x/c)$ in the arguments for the cosine function in Eqs. (13.8.13) and (13.8.14)?

Consider first $x > 0$. If we are sitting at some $x > 0$ at time t , and are measuring an electric field there, the field we are observing should not depend on what the current sheet is doing *at that* observation time t . Information about what the current sheet is doing takes a time x/c to propagate out to the observer at $x > 0$. Thus what the observer at $x > 0$ sees at time t depends on what the current sheet was doing *at an earlier time*, namely $t - x/c$. The electric field as a function of time should reflect that time delay due to the finite speed of propagation from the origin to some $x > 0$, and this is the reason the $(t - x/c)$ appears in Eq. (13.8.13), and not t itself. For $x < 0$, the argument is exactly the same, except if $x < 0$, $t + x/c$ is the expression for the earlier time, and not $t - x/c$. This is exactly the time-delay effect one gets when one measures waves on a string. If we are measuring wave amplitudes on a string some distance away from the agent who is shaking the string to generate the waves, what we measure at time t depends on what the

agent was doing at an earlier time, allowing for the wave to propagate from the agent to the observer.

If we note that $\cos \omega(t - x/c) = \cos(\omega t - kx)$ where $k = \omega/c$ is the wave number, we see that Eqs. (13.8.13) and (13.8.14) are precisely the kinds of plane electromagnetic waves we have studied. Note that we can also easily arrange to get rid of our static field $\vec{\mathbf{E}}_0$ by simply putting a stationary charged sheet with charge per unit area $-\sigma$ at $x=0$. That charged sheet will cancel out the static field due to the positive sheet of charge, but will not affect the perturbation field we have calculated, since the negatively-charged sheet is not moving. In reality, that is how electromagnetic waves are generated--with an overall neutral medium where charges of one sign (usually the electrons) are accelerated while an equal number of charges of the opposite sign essentially remain at rest. Thus an observer only sees the wave fields, and not the static fields. In the following, we will assume that we have set $\vec{\mathbf{E}}_0$ to zero in this way.

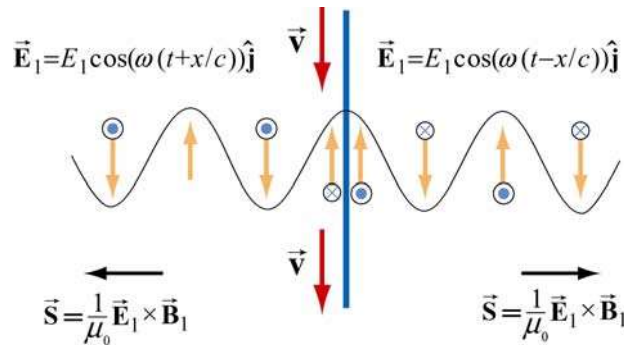

Figure 13.9.4 Electric field generated by the oscillation of a current sheet.

The electric field generated by the oscillation of the current sheet is shown in Figure 13.8.11, for the instant when the sheet is moving *down* and the perturbation electric field is *up*. The magnetic fields, which point into or out of the page, are also shown.

What we have accomplished in the construction here, which really only assumes that the feet of the electric field lines move with the charges, and that information propagates at c is to show we can generate such a wave by shaking a plane of charge sinusoidally. The wave we generate has electric and magnetic fields perpendicular to one another, and transverse to the direction of propagation, with the ratio of the electric field magnitude to the magnetic field magnitude equal to the speed of light. Moreover, we see directly where the energy flux $\vec{\mathbf{S}} = \vec{\mathbf{E}} \times \vec{\mathbf{B}} / \mu_0$ carried off by the wave comes from. The agent who shakes the charges, and thereby generates the electromagnetic wave puts the energy in. If we go to more complicated geometries, these statements become much more complicated in detail, but the overall picture remains as we have presented it.

Let us rewrite slightly the expressions given in Eqs. (13.8.13) and (13.8.14) for the fields generated by our oscillating charged sheet, in terms of the current per unit length in the sheet, $\vec{\mathbf{K}}(t) = \sigma v(t) \hat{\mathbf{j}}$. Since $\vec{\mathbf{v}}(t) = -v_0 \cos \omega t \hat{\mathbf{j}}$, it follows that $\vec{\mathbf{K}}(t) = -\sigma v_0 \cos \omega t \hat{\mathbf{j}}$. Thus,

$$\vec{\mathbf{E}}_1(x, t) = -\frac{c\mu_0}{2} \vec{\mathbf{K}}(t - x/c), \quad \vec{\mathbf{B}}_1(x, t) = \hat{\mathbf{i}} \times \frac{\vec{\mathbf{E}}_1(x, t)}{c} \quad (13.8.15)$$

for $x > 0$, and

$$\vec{\mathbf{E}}_1(x, t) = -\frac{c\mu_0}{2} \vec{\mathbf{K}}(t + x/c), \quad \vec{\mathbf{B}}_1(x, t) = -\hat{\mathbf{i}} \times \frac{\vec{\mathbf{E}}_1(x, t)}{c} \quad (13.8.16)$$

for $x < 0$. Note that $\vec{\mathbf{B}}_1(x, t)$ reverses direction across the current sheet, with a jump of $\mu_0 |\vec{\mathbf{K}}(t)|$ at the sheet, as it must from Ampere's law. *Any* oscillating sheet of current *must* generate the plane electromagnetic waves described by these equations, just as *any* stationary electric charge *must* generate a Coulomb electric field.

Note: To avoid possible future confusion, we point out that in a more advanced electromagnetism course, you will study the radiation fields generated by a *single* oscillating charge, and find that they are proportional to the *acceleration* of the charge. This is very different from the case here, where the radiation fields of our oscillating sheet of charge are proportional to the *velocity* of the charges. However, there is no contradiction, because when you add up the radiation fields due to all the single charges making up our sheet, you recover the same result we give in Eqs. (13.8.15) and (13.8.16) (see Chapter 30, Section 7, of Feynman, Leighton, and Sands, *The Feynman Lectures on Physics, Vol 1*, Addison-Wesley, 1963).

13.9 Summary

- The **Ampere-Maxwell law** reads

$$\oint \vec{\mathbf{B}} \cdot d\vec{\mathbf{s}} = \mu_0 I + \mu_0 \varepsilon_0 \frac{d\Phi_E}{dt} = \mu_0 (I + I_d)$$

where

$$I_d = \varepsilon_0 \frac{d\Phi_E}{dt}$$

is called the **displacement current**. The equation describes how changing electric flux can induce a magnetic field.

- Gauss's law for magnetism is

$$\Phi_B = \oiint_S \vec{\mathbf{B}} \cdot d\vec{\mathbf{A}} = 0$$

The law states that the magnetic flux through a closed surface must be zero, and implies the absence of magnetic monopoles.

- Electromagnetic phenomena are described by the **Maxwell's equations**:

$$\begin{aligned} \oiint_S \vec{\mathbf{E}} \cdot d\vec{\mathbf{A}} &= \frac{Q}{\epsilon_0} & \oint \vec{\mathbf{E}} \cdot d\vec{\mathbf{s}} &= -\frac{d\Phi_B}{dt} \\ \oiint_S \vec{\mathbf{B}} \cdot d\vec{\mathbf{A}} &= 0 & \oint \vec{\mathbf{B}} \cdot d\vec{\mathbf{s}} &= \mu_0 I + \mu_0 \epsilon_0 \frac{d\Phi_E}{dt} \end{aligned}$$

- In free space, the electric and magnetic components of the electromagnetic wave obey a wave equation:

$$\left(\frac{\partial^2}{\partial x^2} - \mu_0 \epsilon_0 \frac{\partial^2}{\partial t^2} \right) \begin{Bmatrix} E_y(x,t) \\ B_z(x,t) \end{Bmatrix} = 0$$

- The magnitudes and the amplitudes of the electric and magnetic fields in an electromagnetic wave are related by

$$\frac{E}{B} = \frac{E_0}{B_0} = \frac{\omega}{k} = c = \frac{1}{\sqrt{\mu_0 \epsilon_0}} \approx 3.00 \times 10^8 \text{ m/s}$$

- A **standing electromagnetic wave** does not propagate, but instead the electric and magnetic fields execute simple harmonic motion perpendicular to the would-be direction of propagation. An example of a standing wave is

$$E_y(x,t) = 2E_0 \sin kx \sin \omega t, \quad B_z(x,t) = 2B_0 \cos kx \cos \omega t$$

- The energy flow rate of an electromagnetic wave through a closed surface is given by

$$\frac{dU}{dt} = -\oiint_S \vec{\mathbf{S}} \cdot d\vec{\mathbf{A}}$$

where

$$\vec{\mathbf{S}} = \frac{1}{\mu_0} \vec{\mathbf{E}} \times \vec{\mathbf{B}}$$

is the **Poynting vector**, and \vec{S} points in the direction the wave propagates.

- The **intensity** of an electromagnetic wave is related to the average energy density by

$$I = \langle S \rangle = c \langle u \rangle$$

- The momentum transferred is related to the energy absorbed by

$$\Delta p = \begin{cases} \frac{\Delta U}{c} & \text{(complete absorption)} \\ 2 \frac{\Delta U}{c} & \text{(complete reflection)} \end{cases}$$

- The average **radiation pressure** on a surface by a normally incident electromagnetic wave is

$$P = \begin{cases} \frac{I}{c} & \text{(complete absorption)} \\ \frac{2I}{c} & \text{(complete reflection)} \end{cases}$$

13.10 Appendix: Reflection of Electromagnetic Waves at Conducting Surfaces

How does a very good conductor reflect an electromagnetic wave falling on it? In words, what happens is the following. The time-varying electric field of the incoming wave drives an oscillating current on the surface of the conductor, following Ohm's law. That oscillating current sheet, of necessity, must generate waves propagating in both directions from the sheet. One of these waves is the reflected wave. The other wave cancels out the incoming wave inside the conductor. Let us make this qualitative description quantitative.

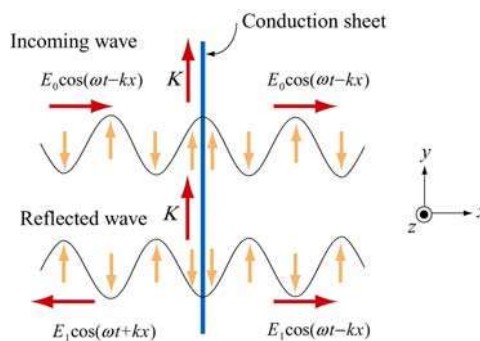

Figure 13.10.1 Reflection of electromagnetic waves at conducting surface

Suppose we have an infinite plane wave propagating in the $+x$ -direction, with

$$\vec{\mathbf{E}}_0 = E_0 \cos(\omega t - kx) \hat{\mathbf{j}}, \quad \vec{\mathbf{B}}_0 = B_0 \cos(\omega t - kx) \hat{\mathbf{k}} \quad (13.10.1)$$

as shown in the top portion of Figure 13.10.1. We put at the origin ($x = 0$) a conducting sheet with width D , which is much smaller than the wavelength of the incoming wave.

This conducting sheet will *reflect* our incoming wave. How? The electric field of the incoming wave will cause a current $\vec{\mathbf{J}} = \vec{\mathbf{E}}/\rho$ to flow in the sheet, where ρ is the resistivity (not to be confused with charge per unit volume), and is equal to the reciprocal of conductivity σ (not to be confused with charge per unit area). Moreover, the direction of $\vec{\mathbf{J}}$ will be in the same direction as the electric field of the incoming wave, as shown in the sketch. Thus our incoming wave sets up an oscillating sheet of current with current per unit length $\vec{\mathbf{K}} = \vec{\mathbf{J}}D$. As in our discussion of the generation of plane electromagnetic waves above, this current sheet will also generate electromagnetic waves, moving both to the right and to the left (see lower portion of Figure 13.10.1) away from the oscillating sheet of charge. Using Eq. (13.8.15) for $x > 0$ the wave generated by the current will be

$$\vec{\mathbf{E}}_1(x, t) = -\frac{c\mu_0 JD}{2} \cos(\omega t - kx) \hat{\mathbf{j}} \quad (13.10.2)$$

where $J = |\vec{\mathbf{J}}|$. For $x < 0$, we will have a similar expression, except that the argument will be $(\omega t + kx)$ (see Figure 13.10.1). Note the sign of this electric field $\vec{\mathbf{E}}_1$ at $x = 0$; it is *down* ($-\hat{\mathbf{j}}$) when the sheet of current is *up* (and $\vec{\mathbf{E}}_0$ is *up*, $+\hat{\mathbf{j}}$), and vice-versa, just as we saw before. Thus, for $x > 0$, the generated electric field $\vec{\mathbf{E}}_1$ will always be *opposite* the direction of the electric field of the incoming wave, and *it will tend to cancel out the incoming wave for $x > 0$* . For a very good conductor, we have (see next section)

$$K = |\vec{\mathbf{K}}| = JD = \frac{2E_0}{c\mu_0} \quad (13.10.3)$$

so that for $x > 0$ we will have

$$\vec{\mathbf{E}}_1(x, t) = -E_0 \cos(\omega t - kx) \hat{\mathbf{j}} \quad (13.10.4)$$

That is, for a very good conductor, the electric field of the wave generated by the current will *exactly cancel* the electric field of the incoming wave *for $x > 0$* ! And that's what a very good conductor does. It supports exactly the amount of current per unit length $K = 2E_0/c\mu_0$ needed to cancel out the incoming wave for $x > 0$. For $x < 0$, *this same current* generates a “reflected” wave propagating back in the direction from which the

original incoming wave came, *with the same amplitude as the original incoming wave*. This is how a very good conductor *totally* reflects electromagnetic waves. Below we shall show that K will in fact approach the value needed to accomplish this in the limit the resistivity ρ approaches zero.

In the process of reflection, there is a force per unit area exerted on the conductor. This is just the $\vec{v} \times \vec{B}$ force due to the current \vec{J} flowing in the presence of the magnetic field of the incoming wave, or a force per unit volume of $\vec{J} \times \vec{B}_0$. If we calculate the total force $d\vec{F}$ acting on a cylindrical volume with area dA and length D of the conductor, we find that it is in the $+x$ - direction, with magnitude

$$dF = D |\vec{J} \times \vec{B}_0| dA = DJB_0 dA = \frac{2E_0 B_0 dA}{c\mu_0} \quad (13.10.5)$$

so that the force per unit area,

$$\frac{dF}{dA} = \frac{2E_0 B_0}{c\mu_0} = \frac{2S}{c} \quad (13.10.6)$$

or radiation pressure, is just twice the Poynting flux divided by the speed of light c .

We shall show that a perfect conductor will perfectly reflect an incident wave. To approach the limit of a perfect conductor, we first consider the finite resistivity case, and then let the resistivity go to zero.

For simplicity, we assume that the sheet is thin compared to a wavelength, so that the entire sheet sees essentially the same electric field. This implies that the current density \vec{J} will be uniform across the thickness of the sheet, and outside of the sheet we will see fields appropriate to an equivalent surface current $\vec{K}(t) = D\vec{J}(t)$. This current sheet will generate additional electromagnetic waves, moving both to the right and to the left, away from the oscillating sheet of charge. The total electric field, $\vec{E}(x, t)$, will be the sum of the incident electric field and the electric field generated by the current sheet. Using Eqs. (13.8.15) and (13.8.16) above, we obtain the following expressions for the total electric field:

$$\vec{E}(x, t) = \vec{E}_0(x, t) + \vec{E}_1(x, t) = \begin{cases} \vec{E}_0(x, t) - \frac{c\mu_0}{2} \vec{K}(t - x/c), & x > 0 \\ \vec{E}_0(x, t) - \frac{c\mu_0}{2} \vec{K}(t + x/c), & x < 0 \end{cases} \quad (13.10.7)$$

We also have a relation between the current density \vec{J} and \vec{E} from the microscopic form of Ohm's law: $\vec{J}(t) = \vec{E}(0, t)/\rho$, where $\vec{E}(0, t)$ is the total electric field at the position of

the conducting sheet. Note that it is appropriate to use the total electric field in Ohm's law -- the currents arise from the total electric field, irrespective of the origin of that field. Thus, we have

$$\vec{\mathbf{K}}(t) = D\vec{\mathbf{J}}(t) = \frac{D\vec{\mathbf{E}}(0,t)}{\rho} \quad (13.10.8)$$

At $x=0$, either expression in Eq. (13.10.7) gives

$$\begin{aligned} \vec{\mathbf{E}}(0,t) &= \vec{\mathbf{E}}_0(0,t) + \vec{\mathbf{E}}_1(0,t) = \vec{\mathbf{E}}_0(0,t) - \frac{c\mu_0}{2}\vec{\mathbf{K}}(t) \\ &= \vec{\mathbf{E}}_0(0,t) - \frac{Dc\mu_0\vec{\mathbf{E}}(0,t)}{2\rho} \end{aligned} \quad (13.10.9)$$

where we have used Eq. (13.10.9) for the last step. Solving for $\vec{\mathbf{E}}(0,t)$, we obtain

$$\vec{\mathbf{E}}(0,t) = \frac{\vec{\mathbf{E}}_0(0,t)}{1 + Dc\mu_0/2\rho} \quad (13.10.10)$$

Using the expression above, the surface current density in Eq. (13.10.8) can be rewritten as

$$\vec{\mathbf{K}}(t) = D\vec{\mathbf{J}}(t) = \frac{D\vec{\mathbf{E}}_0(0,t)}{\rho + Dc\mu_0/2} \quad (13.10.11)$$

In the limit where $\rho \approx 0$ (no resistance, a perfect conductor), $\vec{\mathbf{E}}(0,t) = \vec{\mathbf{0}}$, as can be seen from Eq. (13.10.8), and the surface current becomes

$$\vec{\mathbf{K}}(t) = \frac{2\vec{\mathbf{E}}_0(0,t)}{c\mu_0} = \frac{2E_0}{c\mu_0} \cos \omega t \hat{\mathbf{j}} = \frac{2B_0}{\mu_0} \cos \omega t \hat{\mathbf{j}} \quad (13.10.12)$$

In this same limit, the total electric fields can be written as

$$\vec{\mathbf{E}}(x,t) = \begin{cases} (E_0 - E_0) \cos(\omega t - kx) \hat{\mathbf{j}} = \vec{\mathbf{0}}, & x > 0 \\ E_0 [\cos(\omega t - kx) - \cos(\omega t + kx)] \hat{\mathbf{j}} = 2E_0 \sin \omega t \sin kx \hat{\mathbf{j}}, & x < 0 \end{cases} \quad (13.10.13)$$

Similarly, the total magnetic fields in this limit are given by

$$\begin{aligned}\vec{\mathbf{B}}(x, t) &= \vec{\mathbf{B}}_0(x, t) + \vec{\mathbf{B}}_1(x, t) = B_0 \cos(\omega t - kx) \hat{\mathbf{k}} + \hat{\mathbf{i}} \times \left(\frac{\vec{\mathbf{E}}_1(x, t)}{c} \right) \\ &= B_0 \cos(\omega t - kx) \hat{\mathbf{k}} - B_0 \cos(\omega t - kx) \hat{\mathbf{k}} = \vec{\mathbf{0}}\end{aligned}\quad (13.10.14)$$

for $x > 0$, and

$$\vec{\mathbf{B}}(x, t) = B_0 [\cos(\omega t - kx) + \cos(\omega t + kx)] \hat{\mathbf{k}} = 2B_0 \cos \omega t \cos kx \hat{\mathbf{k}} \quad (13.10.15)$$

for $x < 0$. Thus, from Eqs. (13.10.13) - (13.10.15) we see that we get no electromagnetic wave for $x > 0$, and standing electromagnetic waves for $x < 0$. Note that at $x = 0$, the total electric field vanishes. The current per unit length at $x = 0$,

$$\vec{\mathbf{K}}(t) = \frac{2B_0}{\mu_0} \cos \omega t \hat{\mathbf{j}} \quad (13.10.16)$$

is just the current per length we need to bring the magnetic field down from its value at $x < 0$ to zero for $x > 0$.

You may be perturbed by the fact that in the limit of a perfect conductor, the electric field vanishes at $x = 0$, since it is the electric field at $x = 0$ that is driving the current there! In the limit of very small resistance, the electric field required to drive any finite current is very small. In the limit where $\rho = 0$, the electric field is zero, but as we approach that limit, we can still have a perfectly finite and well determined value of $\vec{\mathbf{J}} = \vec{\mathbf{E}}/\rho$, as we found by taking this limit in Eqs. (13.10.8) and (13.10.12) above.

13.11 Problem-Solving Strategy: Traveling Electromagnetic Waves

This chapter explores various properties of the electromagnetic waves. The electric and the magnetic fields of the wave obey the wave equation. Once the functional form of either one of the fields is given, the other can be determined from Maxwell's equations. As an example, let's consider a sinusoidal electromagnetic wave with

$$\vec{\mathbf{E}}(z, t) = E_0 \sin(kz - \omega t) \hat{\mathbf{i}}$$

The equation above contains the complete information about the electromagnetic wave:

1. Direction of wave propagation: The argument of the sine form in the electric field can be rewritten as $(kz - \omega t) = k(z - vt)$, which indicates that the wave is propagating in the $+z$ -direction.
2. Wavelength: The wavelength λ is related to the wave number k by $\lambda = 2\pi/k$.

3. Frequency: The frequency of the wave, f , is related to the angular frequency ω by $f = \omega / 2\pi$.
4. Speed of propagation: The speed of the wave is given by

$$v = \lambda f = \frac{2\pi}{k} \cdot \frac{\omega}{2\pi} = \frac{\omega}{k}$$

In vacuum, the speed of the electromagnetic wave is equal to the speed of light, c .

5. Magnetic field $\vec{\mathbf{B}}$: The magnetic field $\vec{\mathbf{B}}$ is perpendicular to both $\vec{\mathbf{E}}$ which points in the $+x$ -direction, and $+\hat{\mathbf{k}}$, the unit vector along the $+z$ -axis, which is the direction of propagation, as we have found. In addition, since the wave propagates in the same direction as the cross product $\vec{\mathbf{E}} \times \vec{\mathbf{B}}$, we conclude that $\vec{\mathbf{B}}$ must point in the $+y$ -direction (since $\hat{\mathbf{i}} \times \hat{\mathbf{j}} = \hat{\mathbf{k}}$).

Since $\vec{\mathbf{B}}$ is always in phase with $\vec{\mathbf{E}}$, the two fields have the same functional form. Thus, we may write the magnetic field as

$$\vec{\mathbf{B}}(z, t) = B_0 \sin(kz - \omega t) \hat{\mathbf{j}}$$

where B_0 is the amplitude. Using Maxwell's equations one may show that $B_0 = E_0(k/\omega) = E_0/c$ in vacuum.

6. The Poynting vector: Using Eq. (13.6.5), the Poynting vector can be obtained as

$$\vec{\mathbf{S}} = \frac{1}{\mu_0} \vec{\mathbf{E}} \times \vec{\mathbf{B}} = \frac{1}{\mu_0} \left[E_0 \sin(kz - \omega t) \hat{\mathbf{i}} \right] \times \left[B_0 \sin(kz - \omega t) \hat{\mathbf{j}} \right] = \frac{E_0 B_0 \sin^2(kz - \omega t)}{\mu_0} \hat{\mathbf{k}}$$

7. Intensity: The intensity of the wave is equal to the average of S :

$$I = \langle S \rangle = \frac{E_0 B_0}{\mu_0} \langle \sin^2(kz - \omega t) \rangle = \frac{E_0 B_0}{2\mu_0} = \frac{E_0^2}{2c\mu_0} = \frac{cB_0^2}{2\mu_0}$$

8. Radiation pressure: If the electromagnetic wave is normally incident on a surface and the radiation is completely *reflected*, the radiation pressure is

$$P = \frac{2I}{c} = \frac{E_0 B_0}{c\mu_0} = \frac{E_0^2}{c^2\mu_0} = \frac{B_0^2}{\mu_0}$$

13.12 Solved Problems

13.12.1 Plane Electromagnetic Wave

Suppose the electric field of a plane electromagnetic wave is given by

$$\vec{\mathbf{E}}(z, t) = E_0 \cos(kz - \omega t) \hat{\mathbf{i}} \quad (13.12.1)$$

Find the following quantities:

- The direction of wave propagation.
- The corresponding magnetic field $\vec{\mathbf{B}}$.

Solutions:

(a) By writing the argument of the cosine function as $kz - \omega t = k(z - ct)$ where $\omega = ck$, we see that the wave is traveling in the $+z$ direction.

(b) The direction of propagation of the electromagnetic waves coincides with the direction of the Poynting vector which is given by $\vec{\mathbf{S}} = \vec{\mathbf{E}} \times \vec{\mathbf{B}} / \mu_0$. In addition, $\vec{\mathbf{E}}$ and $\vec{\mathbf{B}}$ are perpendicular to each other. Therefore, if $\vec{\mathbf{E}} = E(z, t) \hat{\mathbf{i}}$ and $\vec{\mathbf{S}} = S \hat{\mathbf{k}}$, then $\vec{\mathbf{B}} = B(z, t) \hat{\mathbf{j}}$. That is, $\vec{\mathbf{B}}$ points in the $+y$ -direction. Since $\vec{\mathbf{E}}$ and $\vec{\mathbf{B}}$ are in phase with each other, one may write

$$\vec{\mathbf{B}}(z, t) = B_0 \cos(kz - \omega t) \hat{\mathbf{j}} \quad (13.12.2)$$

To find the magnitude of $\vec{\mathbf{B}}$, we make use of Faraday's law:

$$\oint \vec{\mathbf{E}} \cdot d\vec{\mathbf{s}} = -\frac{d\Phi_B}{dt} \quad (13.12.3)$$

which implies

$$\frac{\partial E_x}{\partial z} = -\frac{\partial B_y}{\partial t} \quad (13.12.4)$$

From the above equations, we obtain

$$-E_0 k \sin(kz - \omega t) = -B_0 \omega \sin(kz - \omega t) \quad (13.12.5)$$

or

$$\frac{E_0}{B_0} = \frac{\omega}{k} = c \quad (13.12.6)$$

Thus, the magnetic field is given by

$$\vec{\mathbf{B}}(z, t) = (E_0 / c) \cos(kz - \omega t) \hat{\mathbf{j}} \quad (13.12.7)$$

13.12.2 One-Dimensional Wave Equation

Verify that, for $\omega = kc$,

$$\begin{aligned} E(x, t) &= E_0 \cos(kx - \omega t) \\ B(x, t) &= B_0 \cos(kx - \omega t) \end{aligned} \quad (13.12.8)$$

satisfy the one-dimensional wave equation:

$$\left(\frac{\partial^2}{\partial x^2} - \frac{1}{c^2} \frac{\partial^2}{\partial t^2} \right) \begin{Bmatrix} E(x, t) \\ B(x, t) \end{Bmatrix} = 0 \quad (13.12.9)$$

Solution:

Differentiating $E = E_0 \cos(kx - \omega t)$ with respect to x gives

$$\frac{\partial E}{\partial x} = -kE_0 \sin(kx - \omega t), \quad \frac{\partial^2 E}{\partial x^2} = -k^2 E_0 \cos(kx - \omega t) \quad (13.12.10)$$

Similarly, differentiating E with respect to t yields

$$\frac{\partial E}{\partial t} = \omega E_0 \sin(kx - \omega t), \quad \frac{\partial^2 E}{\partial t^2} = -\omega^2 E_0 \cos(kx - \omega t) \quad (13.12.11)$$

Thus,

$$\frac{\partial^2 E}{\partial x^2} - \frac{1}{c^2} \frac{\partial^2 E}{\partial t^2} = \left(-k^2 + \frac{\omega^2}{c^2} \right) E_0 \cos(kx - \omega t) = 0 \quad (13.12.12)$$

where we have made use of the relation $\omega = kc$. One may follow a similar procedure to verify the magnetic field.

13.12.3 Poynting Vector of a Charging Capacitor

A parallel-plate capacitor with circular plates of radius R and separated by a distance h is charged through a straight wire carrying current I , as shown in the Figure 13.12.1:

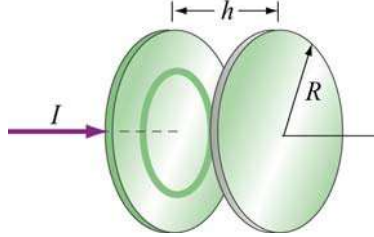

Figure 13.12.1 Parallel plate capacitor

(a) Show that as the capacitor is being charged, the Poynting vector \vec{S} points radially inward toward the center of the capacitor.

(b) By integrating \vec{S} over the cylindrical boundary, show that the rate at which energy enters the capacitor is equal to the rate at which electrostatic energy is being stored in the electric field.

Solutions:

(a) Let the axis of the circular plates be the z -axis, with current flowing in the $+z$ -direction. Suppose at some instant the amount of charge accumulated on the positive plate is $+Q$. The electric field is

$$\vec{E} = \frac{\sigma}{\epsilon_0} \hat{\mathbf{k}} = \frac{Q}{\pi R^2 \epsilon_0} \hat{\mathbf{k}} \quad (13.12.13)$$

According to the Ampere-Maxwell's equation, a magnetic field is induced by changing electric flux:

$$\oint \vec{\mathbf{B}} \cdot d\vec{\mathbf{s}} = \mu_0 I_{\text{enc}} + \mu_0 \epsilon_0 \frac{d}{dt} \iint_s \vec{\mathbf{E}} \cdot d\vec{\mathbf{A}}$$

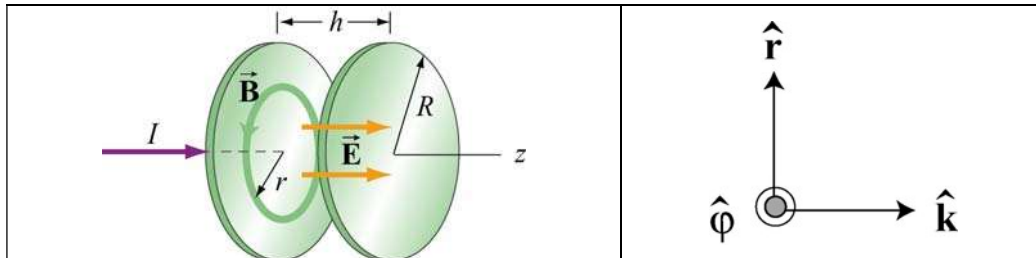

Figure 13.12.2

From the cylindrical symmetry of the system, we see that the magnetic field will be circular, centered on the z -axis, i.e., $\vec{\mathbf{B}} = B\hat{\phi}$ (see Figure 13.12.2.)

Consider a circular path of radius $r < R$ between the plates. Using the above formula, we obtain

$$B(2\pi r) = 0 + \mu_0 \epsilon_0 \frac{d}{dt} \left(\frac{Q}{\pi R^2 \epsilon_0} \pi r^2 \right) = \frac{\mu_0 r^2}{R^2} \frac{dQ}{dt} \quad (13.12.14)$$

or

$$\vec{\mathbf{B}} = \frac{\mu_0 r}{2\pi R^2} \frac{dQ}{dt} \hat{\phi} \quad (13.12.15)$$

The Poynting $\vec{\mathbf{S}}$ vector can then be written as

$$\begin{aligned} \vec{\mathbf{S}} &= \frac{1}{\mu_0} \vec{\mathbf{E}} \times \vec{\mathbf{B}} = \frac{1}{\mu_0} \left(\frac{Q}{\pi R^2 \epsilon_0} \hat{\mathbf{k}} \right) \times \left(\frac{\mu_0 r}{2\pi R^2} \frac{dQ}{dt} \hat{\phi} \right) \\ &= - \left(\frac{Qr}{2\pi^2 R^4 \epsilon_0} \right) \left(\frac{dQ}{dt} \right) \hat{\mathbf{r}} \end{aligned} \quad (13.12.16)$$

Note that for $dQ/dt > 0$ $\vec{\mathbf{S}}$ points in the $-\hat{\mathbf{r}}$ direction, or radially inward toward the center of the capacitor.

(b) The energy per unit volume carried by the electric field is $u_E = \epsilon_0 E^2 / 2$. The total energy stored in the electric field then becomes

$$U_E = u_E V = \frac{\epsilon_0}{2} E^2 (\pi R^2 h) = \frac{1}{2} \epsilon_0 \left(\frac{Q}{\pi R^2 \epsilon_0} \right)^2 \pi R^2 h = \frac{Q^2 h}{2\pi R^2 \epsilon_0} \quad (13.12.17)$$

Differentiating the above expression with respect to t , we obtain the rate at which this energy is being stored:

$$\frac{dU_E}{dt} = \frac{d}{dt} \left(\frac{Q^2 h}{2\pi R^2 \epsilon_0} \right) = \frac{Qh}{\pi R^2 \epsilon_0} \left(\frac{dQ}{dt} \right) \quad (13.12.18)$$

On the other hand, the rate at which energy flows into the capacitor through the cylinder at $r = R$ can be obtained by integrating $\vec{\mathbf{S}}$ over the surface area:

$$\oint \vec{S} \cdot d\vec{A} = SA_R = \left(\frac{Qr}{2\pi^2 \epsilon_0 R^4} \frac{dQ}{dt} \right) (2\pi R h) = \frac{Qh}{\epsilon_0 \pi R^2} \left(\frac{dQ}{dt} \right) \quad (13.12.19)$$

which is equal to the rate at which energy stored in the electric field is changing.

13.12.4 Poynting Vector of a Conductor

A cylindrical conductor of radius a and conductivity σ carries a steady current I which is distributed uniformly over its cross-section, as shown in Figure 13.12.3.

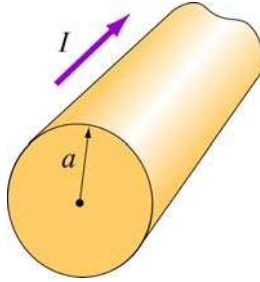

Figure 13.12.3

- Compute the electric field \vec{E} inside the conductor.
- Compute the magnetic field \vec{B} just outside the conductor.
- Compute the Poynting vector \vec{S} at the surface of the conductor. In which direction does \vec{S} point?
- By integrating \vec{S} over the surface area of the conductor, show that the rate at which electromagnetic energy enters the surface of the conductor is equal to the rate at which energy is dissipated.

Solutions:

- Let the direction of the current be along the z -axis. The electric field is given by

$$\vec{E} = \frac{\vec{J}}{\sigma} = \frac{I}{\sigma \pi a^2} \hat{k} \quad (13.12.20)$$

where R is the resistance and l is the length of the conductor.

- The magnetic field can be computed using Ampere's law:

$$\oint \vec{\mathbf{B}} \cdot d\vec{\mathbf{s}} = \mu_0 I_{\text{enc}} \quad (13.12.21)$$

Choosing the Amperian loop to be a circle of radius r , we have $B(2\pi r) = \mu_0 I$, or

$$\vec{\mathbf{B}} = \frac{\mu_0 I}{2\pi r} \hat{\boldsymbol{\phi}} \quad (13.12.22)$$

(c) The Poynting vector on the surface of the wire ($r = a$) is

$$\vec{\mathbf{S}} = \frac{\vec{\mathbf{E}} \times \vec{\mathbf{B}}}{\mu_0} = \frac{1}{\mu_0} \left(\frac{I}{\sigma \pi a^2} \hat{\mathbf{k}} \right) \times \left(\frac{\mu_0 I}{2\pi a} \hat{\boldsymbol{\phi}} \right) = - \left(\frac{I^2}{2\pi^2 \sigma a^3} \right) \hat{\mathbf{r}} \quad (13.12.23)$$

Notice that $\vec{\mathbf{S}}$ points radially inward toward the center of the conductor.

(d) The rate at which electromagnetic energy flows into the conductor is given by

$$P = \frac{dU}{dt} = \oint_S \vec{\mathbf{S}} \cdot d\vec{\mathbf{A}} = \left(\frac{I^2}{2\sigma\pi^2 a^3} \right) 2\pi a l = \frac{I^2 l}{\sigma \pi a^2} \quad (13.12.24)$$

However, since the conductivity σ is related to the resistance R by

$$\sigma = \frac{1}{\rho} = \frac{l}{AR} = \frac{l}{\pi a^2 R} \quad (13.12.25)$$

The above expression becomes

$$P = I^2 R \quad (13.12.26)$$

which is equal to the rate of energy dissipation in a resistor with resistance R .

13.13 Conceptual Questions

1. In the Ampere-Maxwell's equation, is it possible that both a conduction current and a displacement are non-vanishing?
2. What causes electromagnetic radiation?
3. When you touch the indoor antenna on a TV, the reception usually improves. Why?

4. Explain why the reception for cellular phones often becomes poor when used inside a steel-framed building.
5. Compare sound waves with electromagnetic waves.
6. Can parallel electric and magnetic fields make up an electromagnetic wave in vacuum?
7. What happens to the intensity of an electromagnetic wave if the amplitude of the electric field is halved? Doubled?

13.14 Additional Problems

13.14.1 Solar Sailing

It has been proposed that a spaceship might be propelled in the solar system by radiation pressure, using a large sail made of foil. How large must the sail be if the radiation force is to be equal in magnitude to the Sun's gravitational attraction? Assume that the mass of the ship and sail is 1650 kg, that the sail is perfectly reflecting, and that the sail is oriented at right angles to the Sun's rays. Does your answer depend on where in the solar system the spaceship is located?

13.14.2 Reflections of True Love

(a) A light bulb puts out 100 W of electromagnetic radiation. What is the time-average intensity of radiation from this light bulb at a distance of one meter from the bulb? What are the maximum values of electric and magnetic fields, E_0 and B_0 , at this same distance from the bulb? Assume a plane wave.

(b) The face of your true love is one meter from this 100 W bulb. What maximum surface current must flow on your true love's face in order to reflect the light from the bulb into your adoring eyes? Assume that your true love's face is (what else?) perfect--perfectly smooth and perfectly reflecting--and that the incident light and reflected light are normal to the surface.

13.14.3 Coaxial Cable and Power Flow

A coaxial cable consists of two concentric long hollow cylinders of zero resistance; the inner has radius a , the outer has radius b , and the length of both is l , with $l \gg b$. The cable transmits DC power from a battery to a load. The battery provides an electromotive force \mathcal{E} between the two conductors at one end of the cable, and the load is a resistance R connected between the two conductors at the other end of the cable. A

current I flows down the inner conductor and back up the outer one. The battery charges the inner conductor to a charge $-Q$ and the outer conductor to a charge $+Q$.

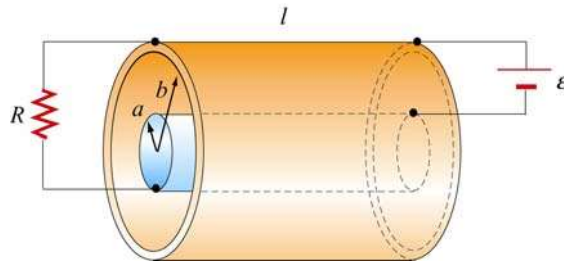

Figure 13.14.1

- Find the direction and magnitude of the electric field \vec{E} everywhere.
- Find the direction and magnitude of the magnetic field \vec{B} everywhere.
- Calculate the Poynting vector \vec{S} in the cable.
- By integrating \vec{S} over appropriate surface, find the power that flows into the coaxial cable.
- How does your result in (d) compare to the power dissipated in the resistor?

13.14.4 Superposition of Electromagnetic Waves

Electromagnetic wave are emitted from two different sources with

$$\vec{E}_1(x, t) = E_{10} \cos(kx - \omega t) \hat{j}, \quad \vec{E}_2(x, t) = E_{20} \cos(kx - \omega t + \phi) \hat{j}$$

- Find the Poynting vector associated with the resultant electromagnetic wave.
- Find the intensity of the resultant electromagnetic wave
- Repeat the calculations above if the direction of propagation of the second electromagnetic wave is reversed so that

$$\vec{E}_1(x, t) = E_{10} \cos(kx - \omega t) \hat{j}, \quad \vec{E}_2(x, t) = E_{20} \cos(kx + \omega t + \phi) \hat{j}$$

13.14.5 Sinusoidal Electromagnetic Wave

The electric field of an electromagnetic wave is given by

$$\vec{E}(z,t) = E_0 \cos(kz - \omega t)(\hat{i} + \hat{j})$$

- (a) What is the maximum amplitude of the electric field?
- (b) Compute the corresponding magnetic field \vec{B} .
- (c) Find the Poynting vector \vec{S} .
- (d) What is the radiation pressure if the wave is incident normally on a surface and is perfectly reflected?

13.14.6 Radiation Pressure of Electromagnetic Wave

A plane electromagnetic wave is described by

$$\vec{E} = E_0 \sin(kx - \omega t)\hat{j}, \quad \vec{B} = B_0 \sin(kx - \omega t)\hat{k}$$

where $E_0 = cB_0$.

- (a) Show that for any point in this wave, the density of the energy stored in the electric field equals the density of the energy stored in the magnetic field. What is the time-averaged *total* (electric plus magnetic) energy density in this wave, in terms of E_0 ? In terms of B_0 ?
- (b) This wave falls on and is totally *absorbed* by an object. Assuming total absorption, show that the radiation pressure on the object is just given by the time-averaged total energy density in the wave. Note that the dimensions of energy density are the same as the dimensions of pressure.
- (c) Sunlight strikes the Earth, just outside its atmosphere, with an average intensity of 1350 W/m^2 . What is the time averaged total energy density of this sunlight? An object in orbit about the Earth totally absorbs sunlight. What radiation pressure does it feel?

13.14.7 Energy of Electromagnetic Waves

- (a) If the electric field of an electromagnetic wave has an rms (root-mean-square) strength of $3.0 \times 10^{-2} \text{ V/m}$, how much energy is transported across a 1.00-cm^2 area in one hour?
- (b) The intensity of the solar radiation incident on the upper atmosphere of the Earth is approximately 1350 W/m^2 . Using this information, estimate the energy contained in a 1.00-m^3 volume near the Earth's surface due to radiation from the Sun.

13.14.8 Wave Equation

Consider a plane electromagnetic wave with the electric and magnetic fields given by

$$\vec{\mathbf{E}}(x,t) = E_z(x,t)\hat{\mathbf{k}}, \quad \vec{\mathbf{B}}(x,t) = B_y(x,t)\hat{\mathbf{j}}$$

Applying arguments similar to that presented in 13.4, show that the fields satisfy the following relationships:

$$\frac{\partial E_z}{\partial x} = \frac{\partial B_y}{\partial t}, \quad \frac{\partial B_y}{\partial x} = \mu_0 \epsilon_0 \frac{\partial E_z}{\partial t}$$

13.14.9 Electromagnetic Plane Wave

An electromagnetic plane wave is propagating in vacuum has a magnetic field given by

$$\vec{\mathbf{B}} = B_0 f(ax + bt)\hat{\mathbf{j}} \quad f(u) = \begin{cases} 1 & 0 < u < 1 \\ 0 & \text{else} \end{cases}$$

The wave encounters an infinite, dielectric sheet at $x = 0$ of such a thickness that half of the energy of the wave is reflected and the other half is transmitted and emerges on the far side of the sheet. The $+\hat{\mathbf{k}}$ direction is out of the paper.

- What condition between a and b must be met in order for this wave to satisfy Maxwell's equations?
- What is the magnitude and direction of the $\vec{\mathbf{E}}$ field of the incoming wave?
- What is the magnitude and direction of the energy flux (power per unit area) carried by the incoming wave, in terms of B_0 and universal quantities?
- What is the pressure (force per unit area) that this wave exerts on the sheet while it is impinging on it?

13.14.10 Sinusoidal Electromagnetic Wave

An electromagnetic plane wave has an electric field given by

$$\vec{\mathbf{E}} = (300 \text{ V/m}) \cos\left(\frac{2\pi}{3}x - 2\pi \times 10^6 t\right)\hat{\mathbf{k}}$$

where x and t are in SI units and $\hat{\mathbf{k}}$ is the unit vector in the $+z$ -direction. The wave is propagating through ferrite, a ferromagnetic insulator, which has a relative magnetic permeability $\kappa_m = 1000$ and dielectric constant $\kappa = 10$.

- (a) What direction does this wave travel?
- (b) What is the wavelength of the wave (in meters)?
- (c) What is the frequency of the wave (in Hz)?
- (d) What is the speed of the wave (in m/s)?
- (e) Write an expression for the associated magnetic field required by Maxwell's equations. Indicate the vector direction of $\vec{\mathbf{B}}$ with a unit vector and a $+$ or $-$, and you should give a numerical value for the amplitude in units of tesla.
- (g) The wave emerges from the medium through which it has been propagating and continues in vacuum. What is the new wavelength of the wave (in meters)?